

M2500-24/32/40C /48C/56C

MIXING CONSOLE

SERVICE MANUAL



M2500-56C

■ CONTENTS

SPECIFICATIONS	3/5
DIMENSIONS	8
PANEL LAYOUT	9
CIRCUIT BOARD LAYOUT	16
DISASSEMBLY PROCEDURE	18
LSI PIN DESCRIPTION	26
IC BLOCK DIAGRAM	30
CIRCUIT BOARDS	33
INSPECTIONS	61/69
TEST PROGRAM	76/78
ERROR MESSAGES	80/81
MIDI IMPLEMENTATION CHART	82
CIRCUIT DIAGRAMS	
PARTS LIST	

IMPORTANT NOTICE

This manual has been provided for the use of authorized Yamaha Retailers and their service personnel. It has been assumed that basic service procedures inherent to the industry, and more specifically Yamaha Products, are already known and understood by the users, and have therefore not been restated.

WARNING : Failure to follow appropriate service and safety procedures when servicing this product may result in personal injury, destruction of expensive components and failure of the product to perform as specified. For these reasons, we advise all Yamaha product owners that all service required should be performed by an authorized Yamaha Retailer or the appointed service representative.

IMPORTANT : This presentation or sale of this manual to any individual or firm does not constitute authorization certification, recognition of any applicable technical capabilities, or establish a principal-agent relationship of any form.

The data provided is believed to be accurate and applicable to the unit(s) indicated on the cover. The research engineering, and service departments of Yamaha are continually striving to improve Yamaha products. Modifications are, therefore, inevitable and changes in specification are subject to change without notice or obligation to retrofit. Should any discrepancy appear to exist, please contact the distributor's Service Division.

WARNING : Static discharges can destroy expensive components. Discharge any static electricity your body may have accumulated by grounding yourself to the ground bus in the unit (heavy gauge black wires connect to this bus.)

IMPORTANT : Turn the unit OFF during disassembly and parts replacement. Recheck all work before you apply power to the unit.

LITHIUM BATTERY HANDLING

This product uses a lithium battery for memory back-up.

WARNING : Lithium batteries are dangerous because they can be exploded by improper handling. Observe the following precautions when handling or replacing lithium batteries.

- Leave lithium battery replacement to qualified service personnel.
- Always replace with batteries of the same type.
- When installing on the PC board by soldering, solder using the connection terminals provided on the battery cells.
- Never solder directly to the cells. Perform the soldering as quickly as possible.
- Never reverse the battery polarities when installing.
- Do not short the batteries.
- Do not attempt to recharge these batteries.
- Do not disassemble the batteries.
- Never heat batteries or throw them into fire.

ADVARSEL!

Lithiumbatteri-Eksplosionsfare ved fejlagtig handling. Udskiftning ma kun ske med batteri af samme fabrikat og type. lever det brugte batteri tilbage til leverandren.

VARNING

Explosionsfara vid felaktigt batteribyte.

Anvand samma batterityp eller en ekvivalent typ som rekommenderas av apparatillverkaren.

Kassera anvant batteri enligt fabrikantens instruktion.

VAROITUS

Paristo voi rajahtaa, jos se on virheellisesti asennettu.

Vaihda paristo ainoastaan laitevalmistajan suosittelemaan tyyppiin.

Havita kaytetty paristo valmistajan ohjeiden mukaisesti.

The following information complies with Dutch official Gazette 1995. 45; ESSENTIALS OF ORDER ON THE COLLECTION OF BATTERIES.

- Please refer to the disassembly procedure for the removal of Back-up Battery.
- Leest u voor het verwijderen van de backup batterij deze beschrijving.

WARNING: CHEMICAL CONTENT NOTICE!

The solder used in the production of this product contains LEAD. In addition, other electrical/electronic and/or plastic (Where applicable) components may also contain traces of chemicals found by the California Health and Welfare Agency (and possibly other entities) to cause cancer and/or birth defects or other reproductive harm.

DO NOT PLACE SOLDER, ELECTRICAL/ELECTRONIC OR PLASTIC COMPONENTS IN YOUR MOUTH FOR ANY REASON WHATSOEVER EVER!

Avoid prolonged, unprotected contact between solder and your skin! When soldering, do not inhale solder fumes or expose eyes to solder/flux vapor!

If you come in contact with solder or components located inside the enclosure of this product, wash your hands before handling food.

WARNING

Components having special characteristics are marked  and must be replaced with parts having specification equal to those originally installed.

SPECIFICATIONS

General specifications

0 dB is referenced to 0.775 Vrms.

Total Harmonic Distortion (Master output)	Less than 0.1% (THD+N) 20 Hz–20 kHz @ +14 dB 600 Ω
Frequency Response (Master Output)	0+1, –3 dB 20 Hz–20 kHz @ +4 dB 600 Ω Gain control at minimum level
Hum & Noise (20 Hz–20 kHz)*1 Rs= 150 Ω	–128 dB Equivalent Input Noise. –99 dB Residual Output Noise. (STEREO OUT, MONO/C OUT, GROUP/AUX OUT, AUX OUT, AUX/GROUP OUT)
Input Gain= Max. Input Pad= OFF Input sensitivity= –60 dB	
	–64 dB(68 dB S/N) STEREO OUT Master Level control and one Ch fader at nominal level.
	–80 dB(84 dB S/N) STEREO OUT, MONO/C OUT Master fader at nominal level and all Ch assign SW's off and all GROUP to ST SW's off.
	–81 dB(85 dB S/N) GROUP1/AUX7–GROUP8/AUX14 OUT Master Level control at nominal level and all Ch assign SW's off. GROUP/AUX FLIP SW off.
	–75 dB(79 dB S/N) AUX1–6, AUX7/GROUP1–AUX14/GROUP8 OUT Master Level control at nominal level and all Ch send controls at minimum. GROUP/AUX FLIP SW off.
	–90 dB(94 dB S/N) MATRIX OUT Master level control at nominal level and all Matrix Mix controls at minimum level.
Crosstalk	–70 dB @ 1 kHz adjacent inputs. –70 dB @ 1 kHz input to output. (CH INPUT) –50 dB @ 1 kHz input to output. (ST CH INPUT)
Maximum Voltage Gain GROUP/AUX FLIP SW= off	60 dB CH INPUT to CH INSERT OUT 84 dB CH INPUT to GROUP1/AUX7–GROUP8/ AUX14 OUT 80 dB CH INPUT to AUX1, 2 OUT(Pre Fader) 90 dB CH INPUT to AUX3–6, AUX7/GROUP1– AUX14/GROUP8 OUT(Post Fader) 84 dB CH INPUT to STEREO OUT(CH to ST) 70 dB CH INPUT to MONITOR OUT(PFL)
CH INPUT PAD SW	26 dB
CH INPUT GAIN control	44 dB variable
ST CH 1A, 2–4 INPUT GAIN control	40 dB variable
ST CH 1B INPUT GAIN control	30 dB variable
CH INPUT High Pass Filter	18 dB/octave roll-off below 80 Hz at –3 dB point.
CH INPUT Equalization +15, –15 dB maximum	HIGH 10 kHz (shelving) HIGH-MID 400– 8 kHz (peaking) LOW-MID 80–1.6 kHz (peaking) LOW 100 Hz (shelving)

ST CH INPUT Equalization

	HIGH	10 kHz (shelving)
	LOW	100 Hz (shelving)

Phantom Power +48 VDC is applied to balanced inputs (via 6.8 kΩ current-limiting/isolation resistors) for powering condenser microphones; may be turned ON or OFF via rear-panel phantom Master switch.
When Master is ON, individual channels may be turned ON or OFF via +48V switches (with red LED) on each input channel.

CH LED Indicators

PEAK	LED(red) built into each CH INPUT turns on when pre-Fader level reaches +17 dB.
NOM	LED(yellow) built into each CH INPUT turns on when pre-Fader level reaches 0 dB.
SIGNAL	LED(green) built into each CH INPUT turns on when pre-Fader level reaches –13 dB.

ST CH LED Indicators

PEAK	LED(red) built into each ST CH INPUT turns on when pre-Fader [L+R] level reaches +17 dB.
NOM	LED(yellow) built into each ST CH INPUT turns on when pre-Fader [L+R] level reaches 0 dB.
SIGNAL	LED(green) built into each ST CH INPUT turns on when pre-Fader [L+R] level reaches –13 dB.

Oscillator/Noise

Switchable sine wave @ 100 Hz, 1 kHz or 10 kHz, or pink noise.

Scene Memory

Direct Scene Memory recall switches (1–8)
Switchable Scene Memory recall (1–128)

VU Meters

11 illuminated meters
(0VU= +4 dB output @ 600Ω load)
#1 ; GROUP1/AUX7•AUX1•AUX7/GROUP1•MATRIX1
#2 ; GROUP2/AUX8•AUX2•AUX8/GROUP2•MATRIX2
#3 ; GROUP3/AUX9•AUX3•AUX9/GROUP3•MATRIX3
#4 ; GROUP4/AUX10•AUX4•AUX10/GROUP4•MATRIX4
#5 ; GROUP5/AUX11•AUX5•AUX11/GROUP5•MATRIX5
#6 ; GROUP6/AUX12•AUX6•AUX12/GROUP6•MATRIX6
#7 ; GROUP7/AUX13•NONE•AUX13/GROUP7•MATRIX7
#8 ; GROUP8/AUX14•NONE•AUX14/GROUP8•MATRIX8
#9 ; STEREO L•PFL/AFL L
#10 ; MONO/C
#11 ; STEREO R•PFL/AFL R

VU Meter Peak Indicators

LED(red) built into each VU meter turns on when output signal is above the level 3 dB lower than clipping level.

Dimension

Height	265 mm
Depth	875 mm (except rear connectors)
Width	2385 mm(56C), 2142 mm(48C), 1899 mm(40C), 1642 mm(32), 1400 mm(24)

Weight

102kg(56C), 93kg(48C), 84kg(40C),
71kg(32), 62kg(24)

*1 Hum & Noise are measured with a 6 dB/octave filter @ 12.7 kHz; equivalent to a 20 kHz filter with infinite dB/octave attenuation.

For European Model

Purchaser/User information specified in EN55103-1 and EN55103-2.
Conformed Environment: E1, E2, E3 and E4.

Input/output characteristics

Input specifications

Connection	PAD	Gain Trim	Actual Load Impedance	For Use With Nominal	Input Level *1			Connector In Mixer	
					Sensitivity *9	Nominal	Max before Clip		
CH INPUT (1-n) *8	0	-60	3 k Ω	50–600 Ω Mics & 600 Ω Lines	-80 dB(0.078 mV)	-60 dB(0.775 mV)	-40 dB(7.75 mV)	XLR-3-31 type *2	
	26				-54 dB(1.55 mV)	-34 dB(15.5 mV)	-14 dB(155 mV)		
	0	-16			-36 dB(12.3 mV)	-16 dB(123 mV)	+4 dB(1.23 V)		
	26				-10 dB(245 mV)	+10 dB(2.45 V)	+30 dB(24.5 V)		
ST CH 1A INPUT [L, R]		-30	5 k Ω	600 Ω Lines	-50 dB(2.45 mV)	-30 dB(24.5 mV)	-10 dB(245 mV)		Phono Jack *3
		+10			-10 dB(245 mV)	+10 dB(2.45 V)	+30 dB(24.5 V)		
ST CH 1B INPUT [L, R]		-20	10 k Ω	600 Ω Lines	-40 dB(7.75 mV)	-20 dB(77.5 mV)	0 dB(0.775 V)		Phone Jack (TRS) *4
		+10			-10 dB(245 mV)	+10 dB(2.45 V)	+30 dB(24.5 V)		
ST CH INPUT [L, R] (2–4)		-30	5 k Ω	600 Ω Lines	-50 dB(2.45 mV)	-30 dB(24.5 mV)	-10 dB(245 mV)	Phone Jack (TRS) *4	
		+10			-10 dB(245 mV)	+10 dB(2.45 V)	+30 dB(24.5 V)		
TALKBACK IN			10 k Ω	50–600 Ω Mics	-66 dB(0.388 mV)	-50 dB(2.45 mV)	-20 dB(77.5 mV)	XLR-3-31 type *5	
MATRIX SUB IN [L, R]			10 k Ω	600 Ω Lines	-2 dB(0.616 V)	+4 dB(1.23 V)	+24 dB(12.3 V)	Phone Jack (TRS) *6	
STEREO [L, R] MONO/C SUB IN					-6 dB(388 mV)				
CH INSERT IN (1-n) *8			10 k Ω	600 Ω Lines	-26 dB(38.8 mV)	0 dB(0.775 V)	+20 dB(7.75 V)	Phone Jack (TRS) *7	
STEREO [L, R] MONO/C INSERT IN GRP/AUX INSERT IN (1/7–8/14) AUX INSERT IN (1–6)					-10 dB(245 mV)				

*1 0 dB=0.775 Vrms.

*2 Balanced.

*3 Unbalanced.

*4 Balanced (T=HOT, R=COLD, S=GND).

*5 Unbalanced.

*6 Unbalanced (T=SIGNAL, R=GND, S=GND).

*7 Unbalanced (T=OUTPUT, R=INPUT, S=GND).

*8 n=56, 48, 40, 32 or 24

*9 Sensitivity is the lowest level that will produce an output of +4 dB(1.23 V), or the nominal output level when the unit is set to maximum level.

Output specifications

Connection	Actual Source Impedance	For Use With Nominal	Output Level *1		Connector In Mixer
			Nominal	Max before Clip	
STEREO OUT [L, R] MONO/C OUT GRP/AUX OUT (1/7–8/14) AUX/GRP OUT (7/1–14/8) AUX OUT (1–6) MONITOR OUT [L, R, MONO/C] MATRIX OUT (1–8)	150 Ω	600 Ω Lines	+4 dB(1.23 V)	+24 dB(12.3 V)	XLR-3-32 type *2
CH INSERT OUT (1-n) *5 STEREO INSERT OUT [L, R] MONO/C INSERT OUT GRP/AUX INSERT OUT (1/7–8/14) AUX INSERT IN (1–6)	600 Ω	10 k Ω Lines	0 dB(0.775 V)	+20 dB(7.75 V)	Phone Jack (TRS) *3
PHONES OUT [L, R]	100 Ω	8 Ω Phones	10 mW	20 mW	Stereo Phone Jack *4
		40 Ω Phones	30 mW	75 mW	

*1 0 dB=0.775 Vrms.

*2 Balanced.

*3 Unbalanced (T=OUTPUT, R=INPUT, S=GND).

*4 Unbalanced.

*5 n=56, 48, 40, 32 or 24

Other

Connector wiring

Pin No.	Signal name
1	Power supply remote
2	+15 V
3	±15 V GND
4	+48 V GND
5	-15 V
6	+12 V
7	+12 V GND / power supply remote
8	Power supply remote
9	+48 V
10	FRAME GND

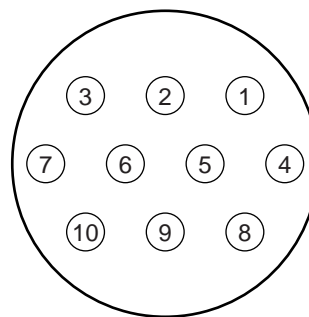

Included items

Power supply connection cable (3 m, 10 pin)

DIMENSIONS

• Front

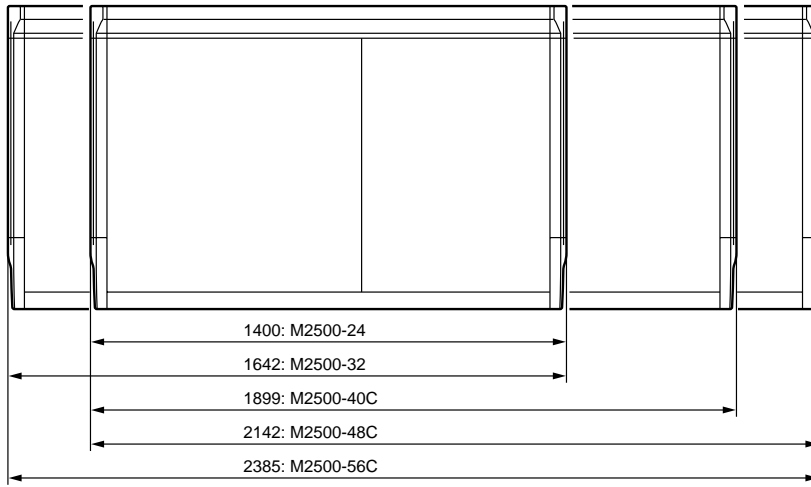

• Side

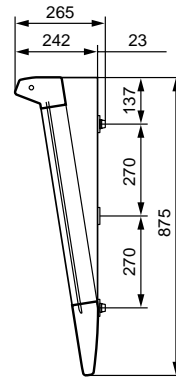

• Rear

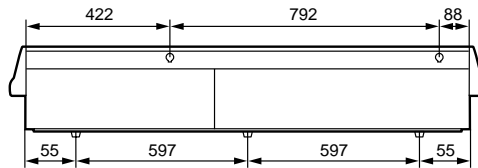

M2500-24

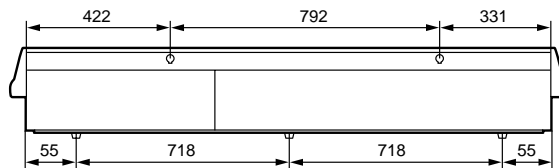

M2500-32

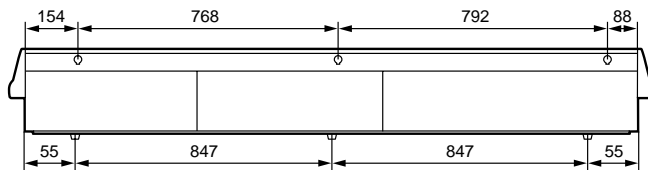

M2500-40C

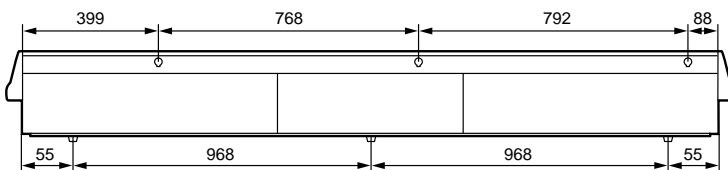

M2500-48C

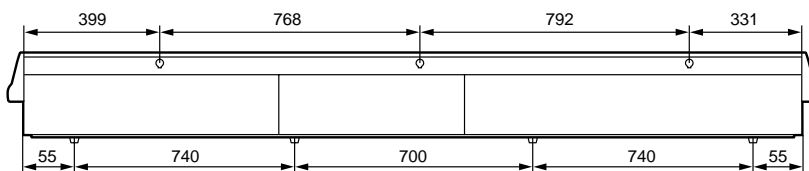

M2500-56C

Units :mm

PANEL LAYOUT

• Control panel

Input channel section

Monoaural input channels

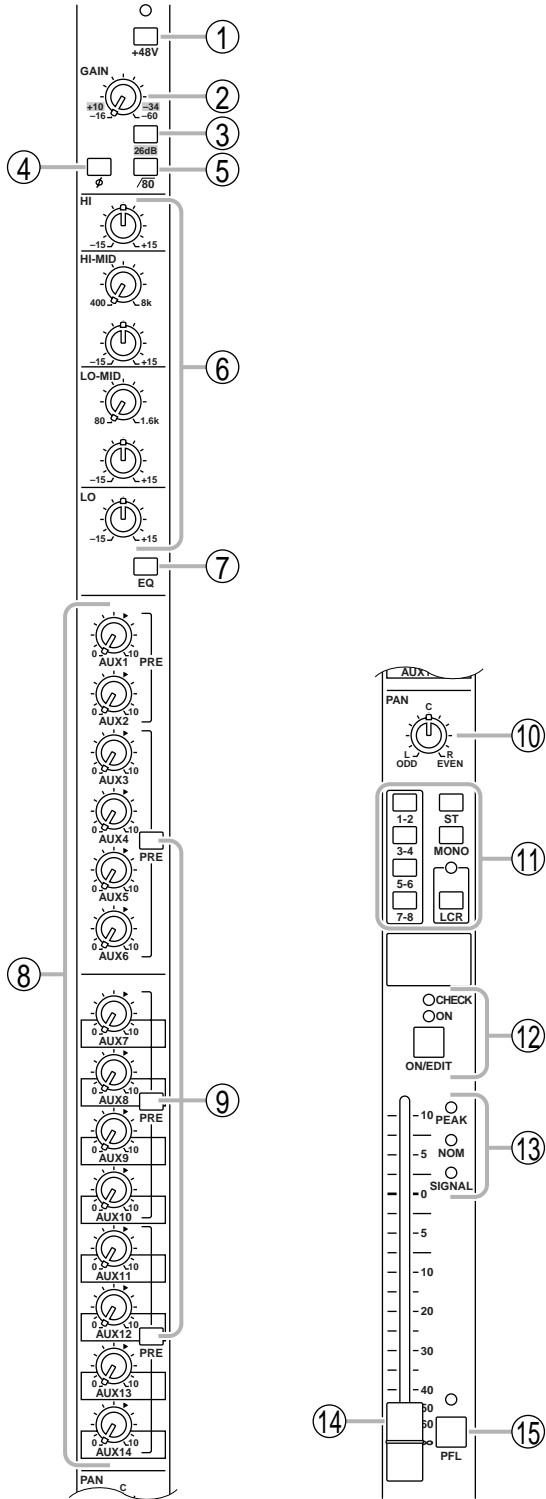

- ① +48 V (phantom power) switch
- ② GAIN control
- ③ 26 dB pad switch
- ④ ϕ (phase) switch
- ⑤ 80 (high pass filter) switch
- ⑥ EQ controls
- ⑦ EQ switch
- ⑧ AUX 1–AUX 14 controls
- ⑨ PRE switches
- ⑩ PAN control
- ⑪ Channel assign switches
- ⑫ ON/EDIT switch / ON, CHECK indicators
- ⑬ PEAK/NOM/SIGNAL indicators
- ⑭ Channel fader
- ⑮ PFL (pre-fader listen) switch

Stereo input channels

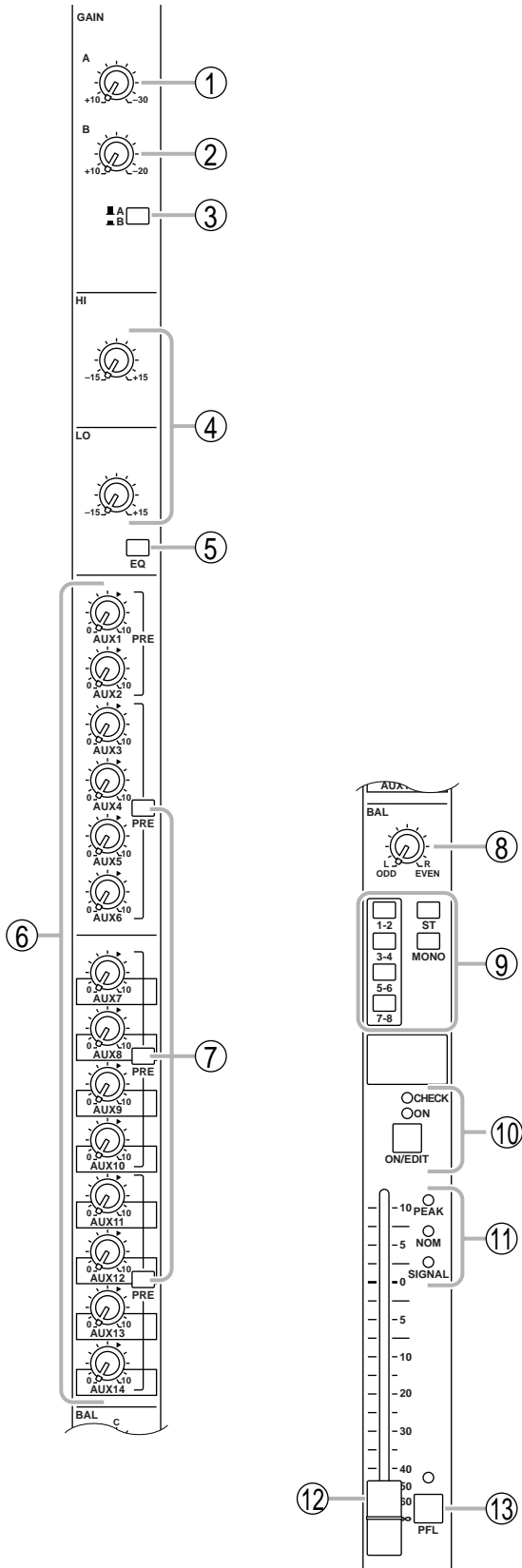

- ① GAIN A control
- ② GAIN B control
- ③ A/B switch
- ④ EQ controls
- ⑤ EQ switch
- ⑥ AUX 1–AUX 14 controls
- ⑦ PRE switches
- ⑧ BAL control
- ⑨ Channel assign switches
- ⑩ ON/EDIT switch / ON, CHECK indicators
- ⑪ PEAK/NOM/SIGNAL indicators
- ⑫ Channel fader
- ⑬ PFL (pre-fader listen) switch

GROUP/AUX master section

AUX 1-6 section

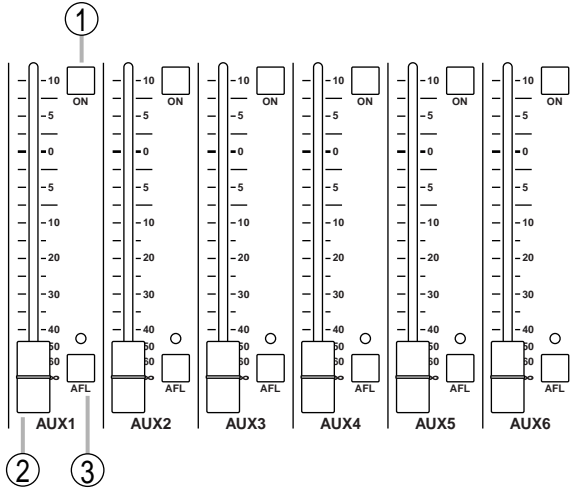

- ① ON switches
- ② AUX 1-6 master faders
- ③ AFL (after fader listen) switches

A7/G1-A14/G8 section

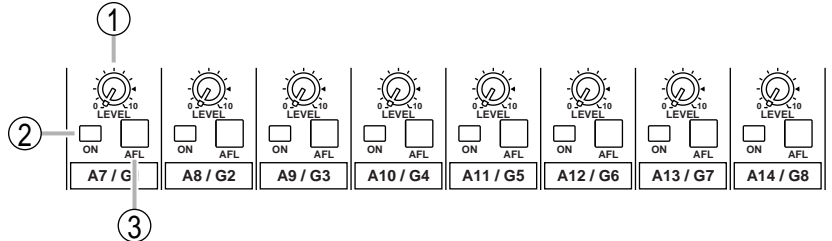

- ① LEVEL control
- ② ON switch
- ③ AFL switch

G1/A7-G8/A14 section

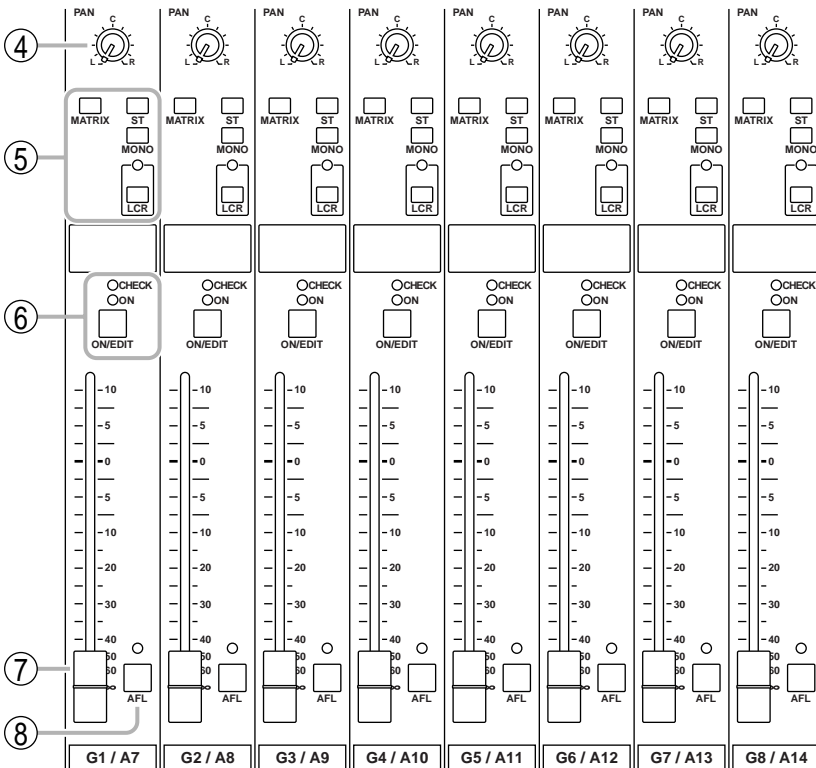

- ④ PAN control
- ⑤ Channel assign switches
- ⑥ ON/CHECK indicators
- ⑦ Fader
- ⑧ AFL (after fader listen) switch

GROUP/AUX FLIP switch

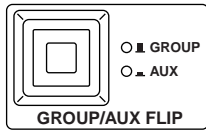

- When GROUP (■) is selected
- When AUX (—) is selected

Stereo/monaural master section
STEREO section MONO/C section

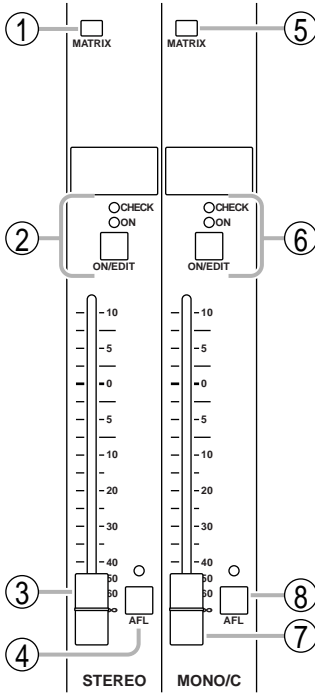

- ① MATRIX switch
- ② ON/EDIT switch / ON, CHECK indicators
- ③ Fader
- ④ AFL switch
- ⑤ MATRIX switch
- ⑥ ON/EDIT switch / ON, CHECK indicators
- ⑦ Fader
- ⑧ AFL switch

Matrix section

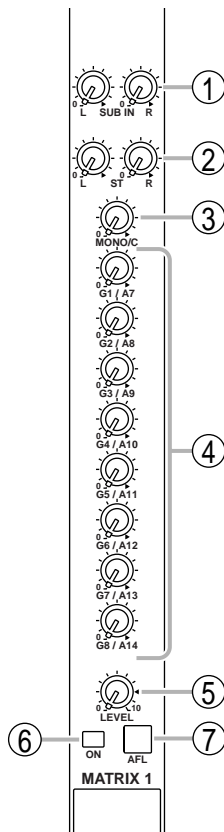

- ① SUB IN L/R control
- ② ST L/R controls
- ③ MONO/C control
- ④ G1/A7–G8/A14 controls
- ⑤ LEVEL control
- ⑥ ON switch
- ⑦ AFL switch

Monitor section

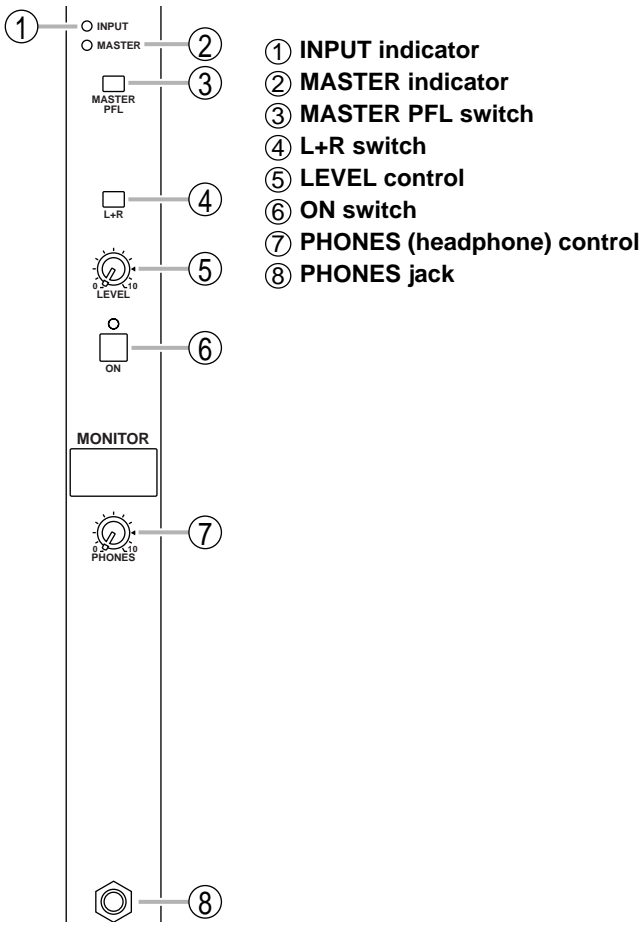

Meter select section

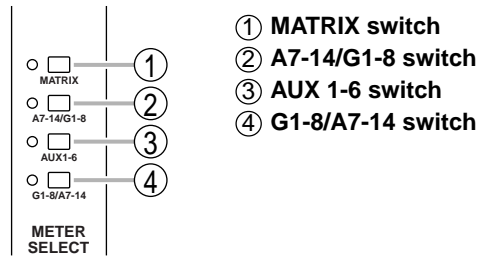

Control section

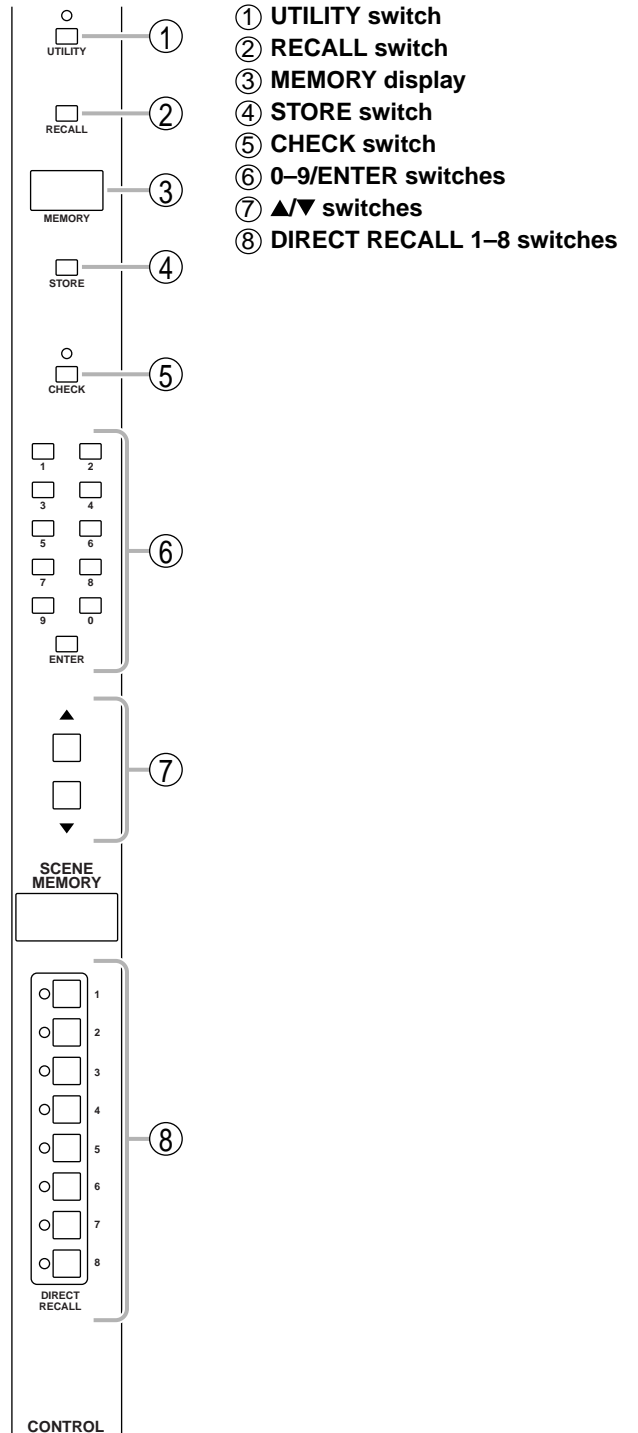

Talkback/oscillator section

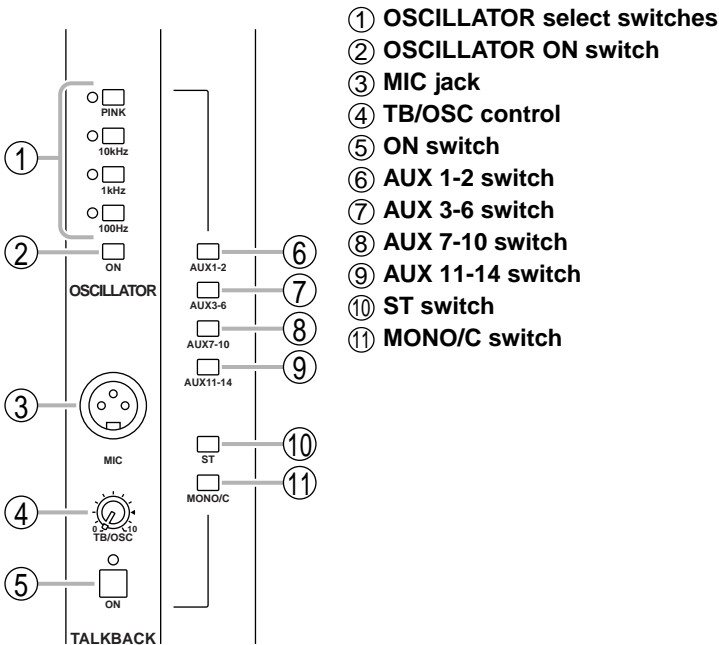

Meter bridge

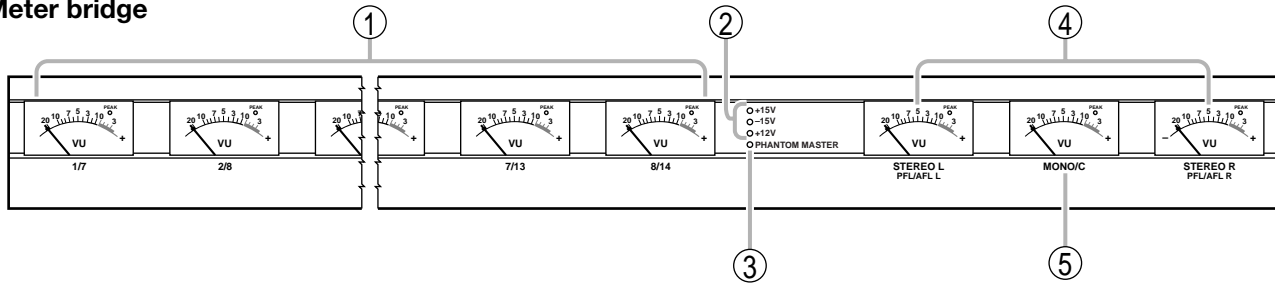

- ① 1/7–8/14 level meters
- ② +15V/–15V/+12V indicators
- ③ PHANTOM MASTER indicator
- ④ STEREO, PFL/AFL level meters
- ⑤ MONO/C level meter

• **Rear panel**

Monaural input channel input/output jacks

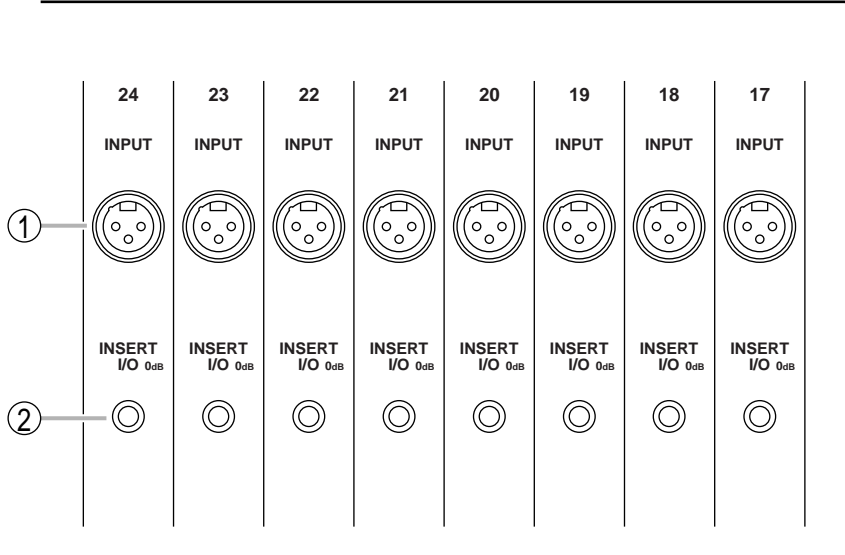

- ① INPUT jacks
- ② INSERT I/O jacks

Stereo input channel input/output jacks

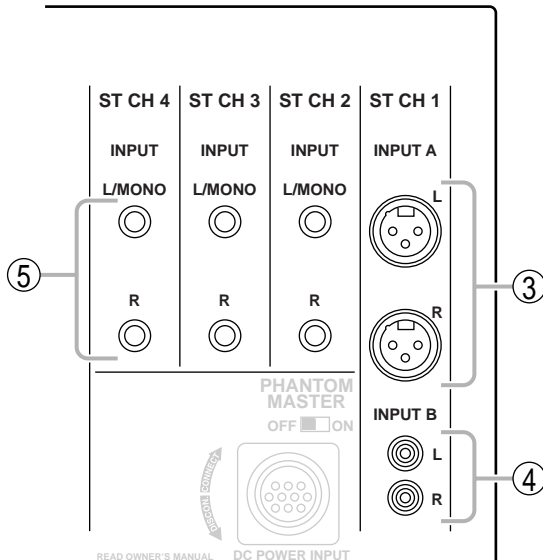

- ③ INPUT A jacks
- ④ INPUT B jacks
- ⑤ INPUT jacks

Master section input/output jacks

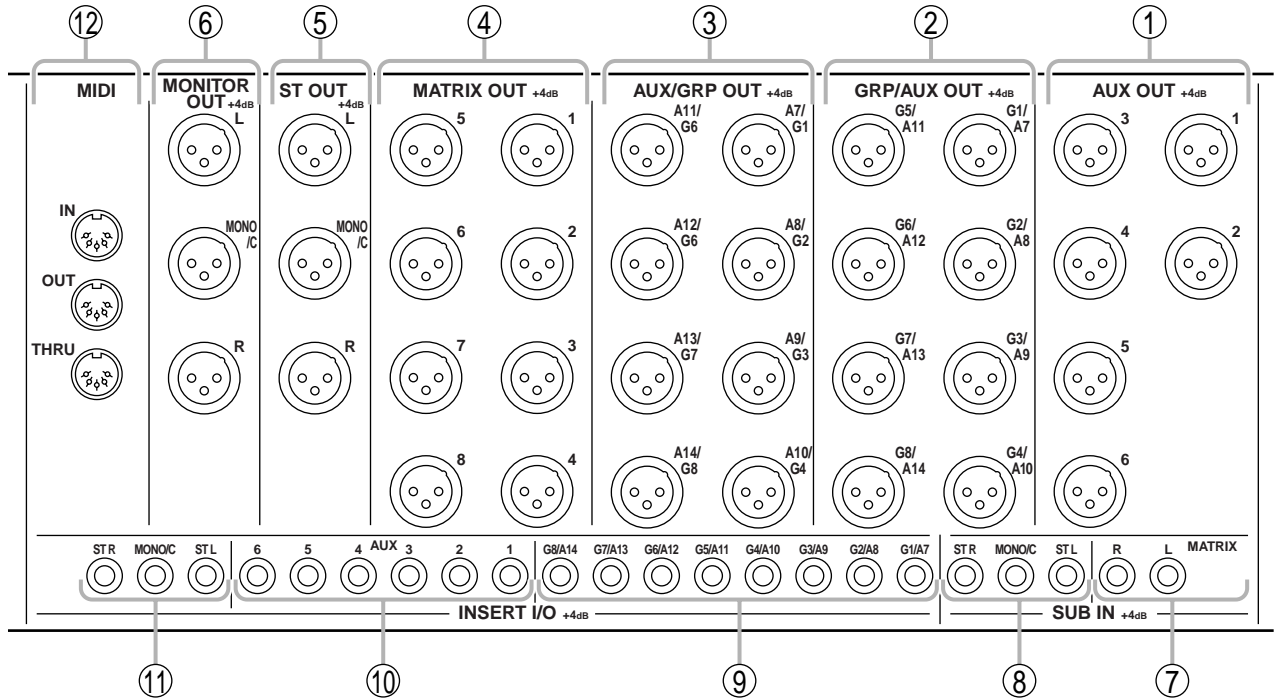

- ① AUX OUT jacks
- ② GRP/AUX OUT jacks
- ③ AUX/GRP OUT jacks
- ④ MATRIX OUT jacks
- ⑤ ST OUT, MONO/C OUT jacks
- ⑥ MONITOR OUT jacks
- ⑦ SUB IN MATRIX jacks
- ⑧ SUB IN ST L/R, MONO/C jack
- ⑨ INSERT I/O G1/A7–G8/A14 jacks
- ⑩ INSERT I/O AUX jacks
- ⑪ INSERT I/O ST L/R, MONO jacks
- ⑫ MIDI connectors

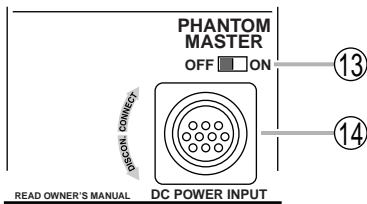

- ⑬ PHANTOM MASTER switch
- ⑭ DC POWER INPUT connector

CIRCUIT BOARD LAYOUT

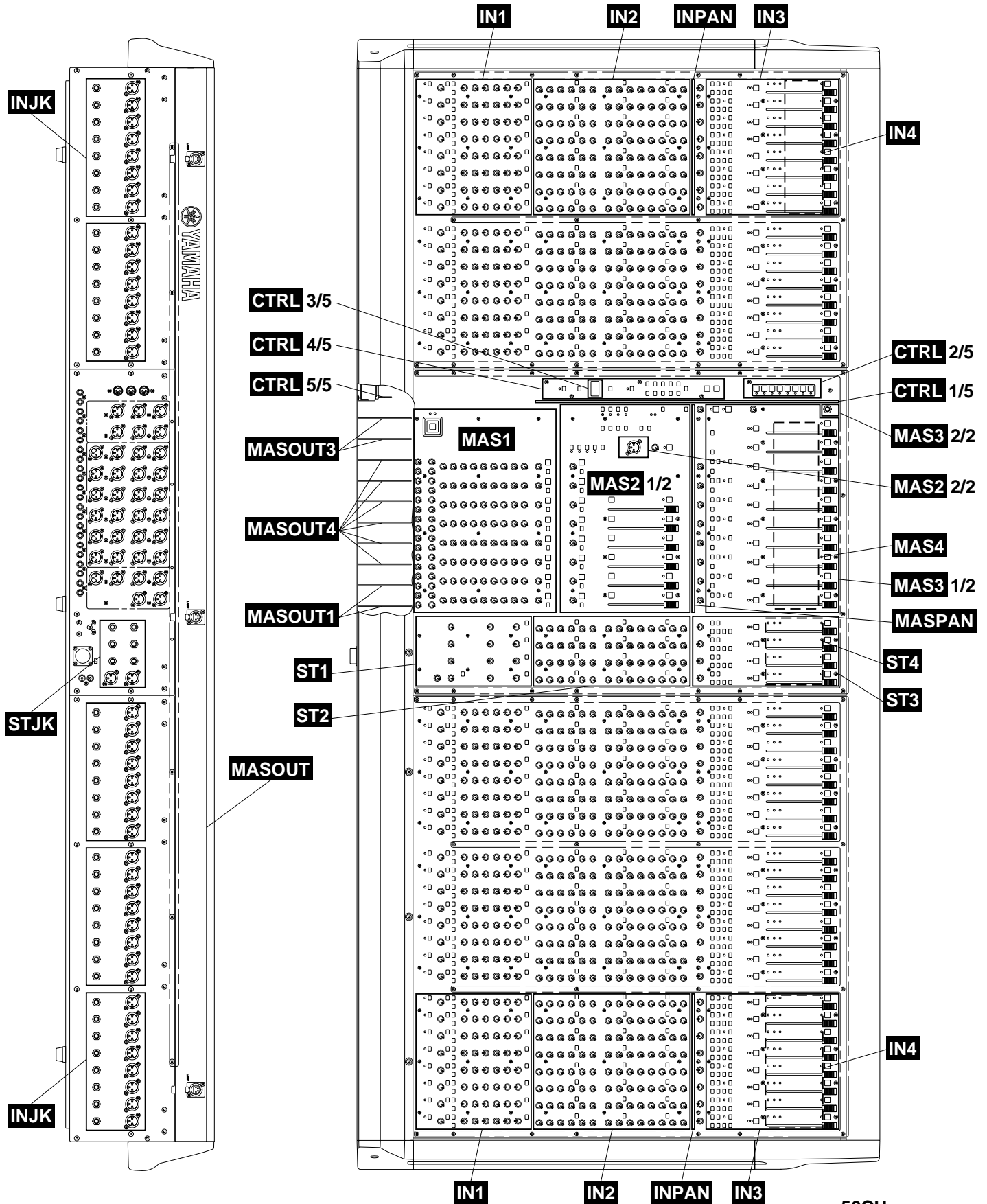

• M2500-56C

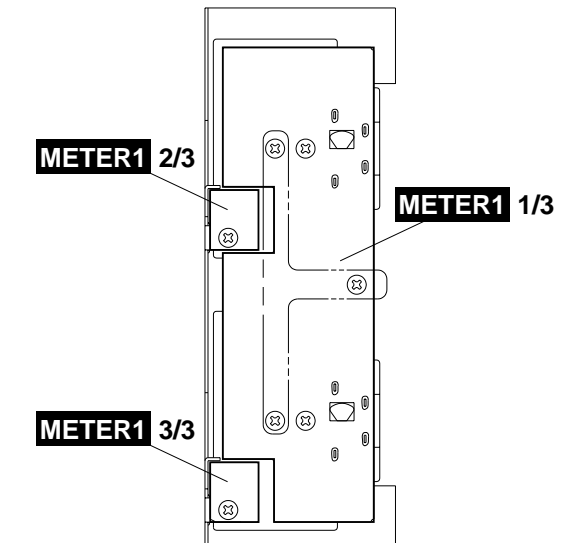
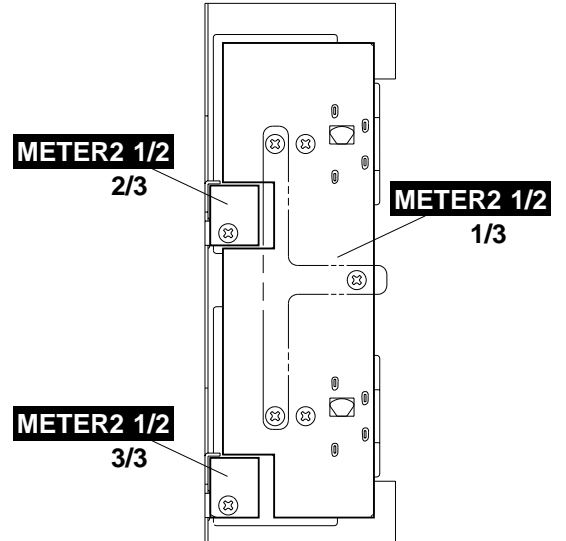
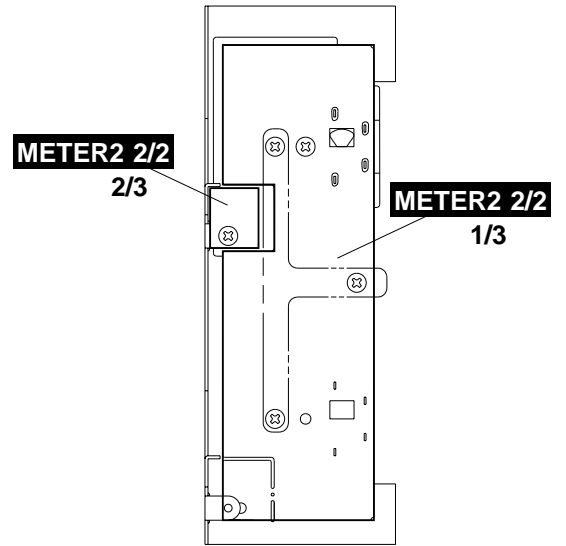
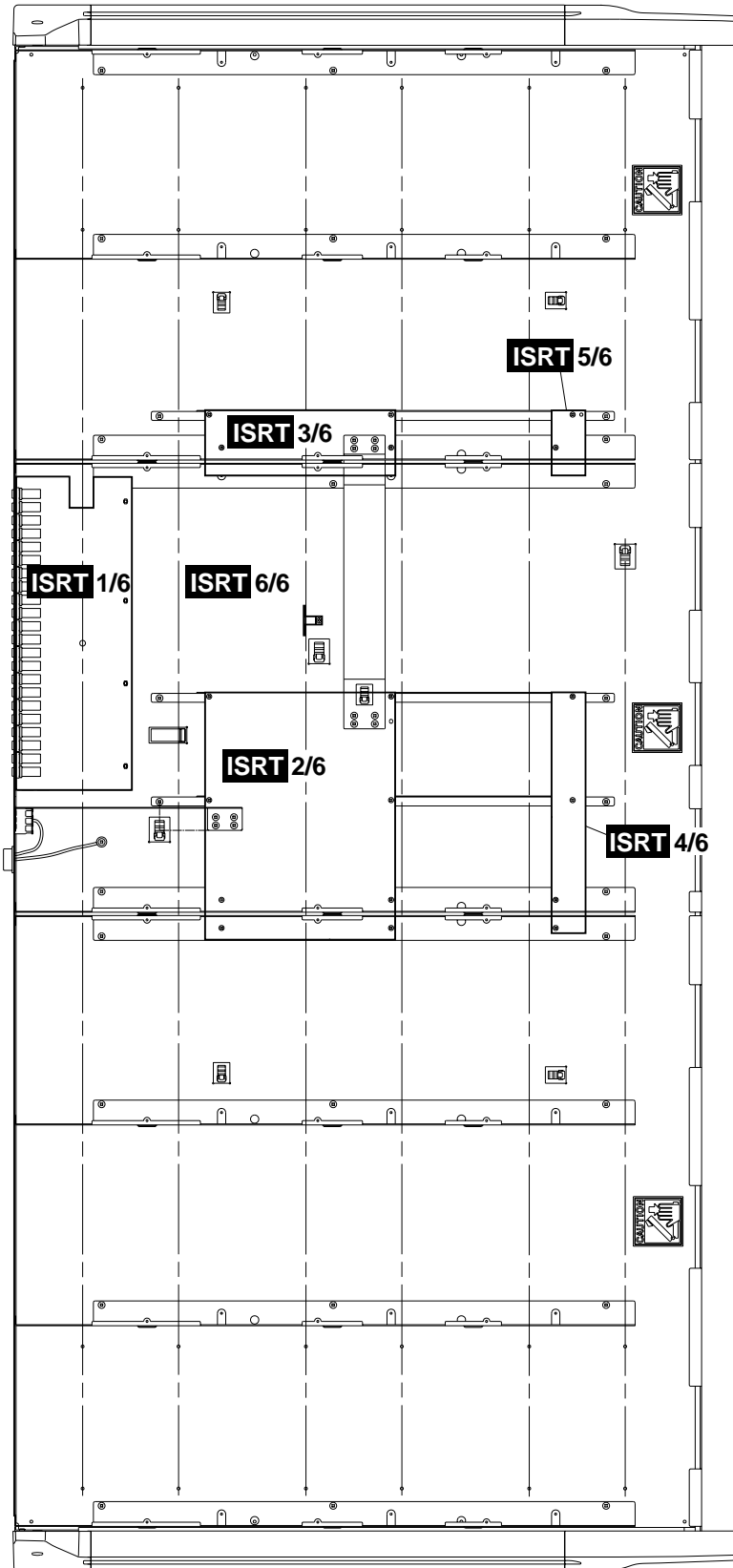

DISASSEMBLY PROCEDURE

A Assembly

1 Meter Panel

- 1-1 Remove the screws marked [210], [220] and [230].
The Meter Panel can then be removed. (Fig. 1)
The type and quantity of the screws marked [210] and [220] are:

[210]: 24CH:10, 32CH:11, 40CH:13, 48CH:14, 56CH:15
[220]: 24CH:7, 32CH:8, 40CH:9, 48CH:10, 56CH:11

2 MONO Assembly

- 2-1 Remove the meter panel (See Procedure 1.)
- 2-2 Remove the screws marked [160] and [180]. (Fig. 1)
Lift the fader side of the control panel and then remove the MONO Assembly by pulling it forward.

[160]: 40CH:21, 56CH:31
[180]: 24CH:26, 32CH:31, 40CH:26, 48CH:52, 56CH:26

• Rear view

(Bottom)

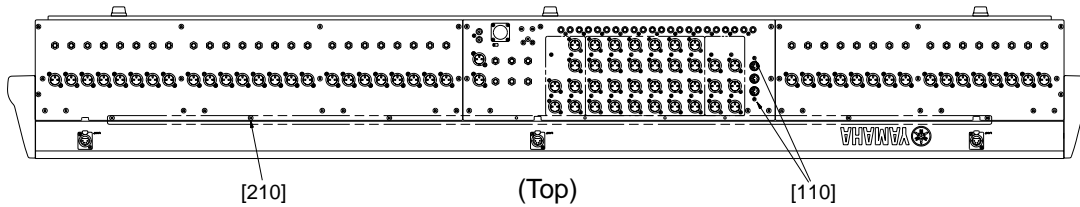

(Top)

• Side view

[230]

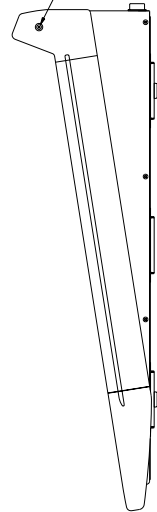

• Top view

(REAR)

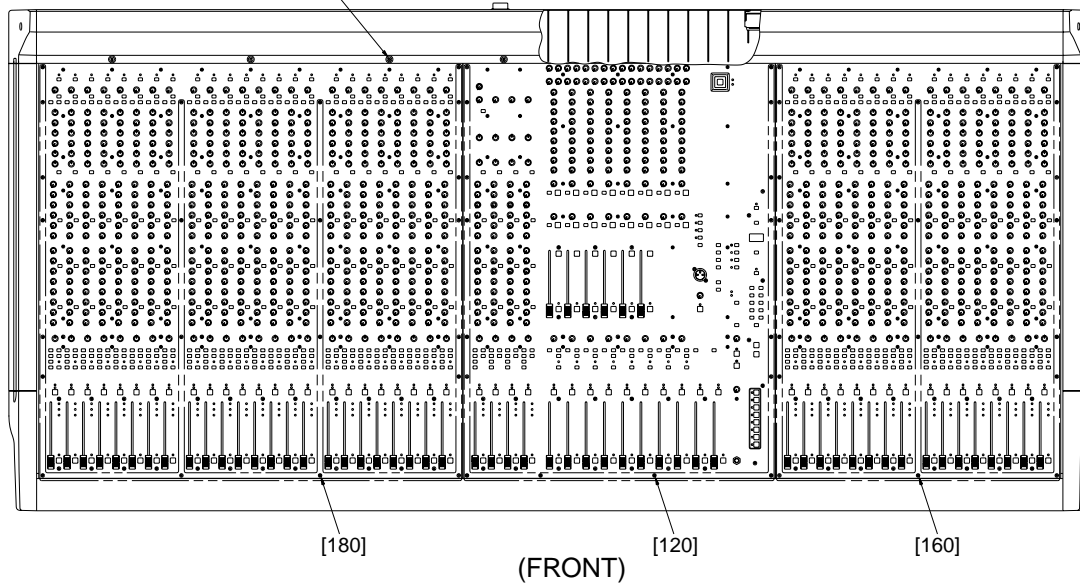

(FRONT)

- [120]: Bind Head Tapping Screw-B 3.0X8 FMZN2BL (EP600190)
- [160]: Bind Head Tapping Screw-B 3.0X8 FMZN2BL (EP600190)
- [180]: Bind Head Tapping Screw-B 3.0X8 FMZN2BL (EP600190)
- [210]: Bind Head Tapping Screw-B 4.0X8 FMZN2BL (EG340190)
- [220]: Bind Head Screw 4.0X8 FMZN2BL (EG340360)
- [230]: Bind Head Screw 4.0X25 MFZN2BL

Fig.1

3 MASTER Assembly

- 3-1 Remove the meter panel. (See Procedure 1.)
- 3-2 Remove the twenty [20] screws marked [120]. Lift the fader side of the control panel, remove the connectors and then remove the MASTER Assembly by pulling it forward. (Fig. 1)

B Circuit Board

1 MONO Assembly

- 1-1 Remove the meter panel. (See Procedure A1.)
- 1-2 Remove the MONO assembly. (See Procedure A2.)
- 1-3 Remove the following circuit boards by removing the screws indicated for each of them. (Fig. 2)

Circuit Board & Unit	Ref No.	PARTS NAME	PARTS No.	Q'ty
IN1	40	Hexagon Socket Tapping Screw-P 3X25 MFZNBL	V3289800	11
IN2	70	Hexagon Socket Tapping Screw-P 3X25 MFZNBL	V3289800	9
IN3	130	Bind Head Tapping Screw-B 3.0X8 MFZN2BL	EP600190	8
IN4	150	PCB Support CS-0305 KSS	EP600230	4

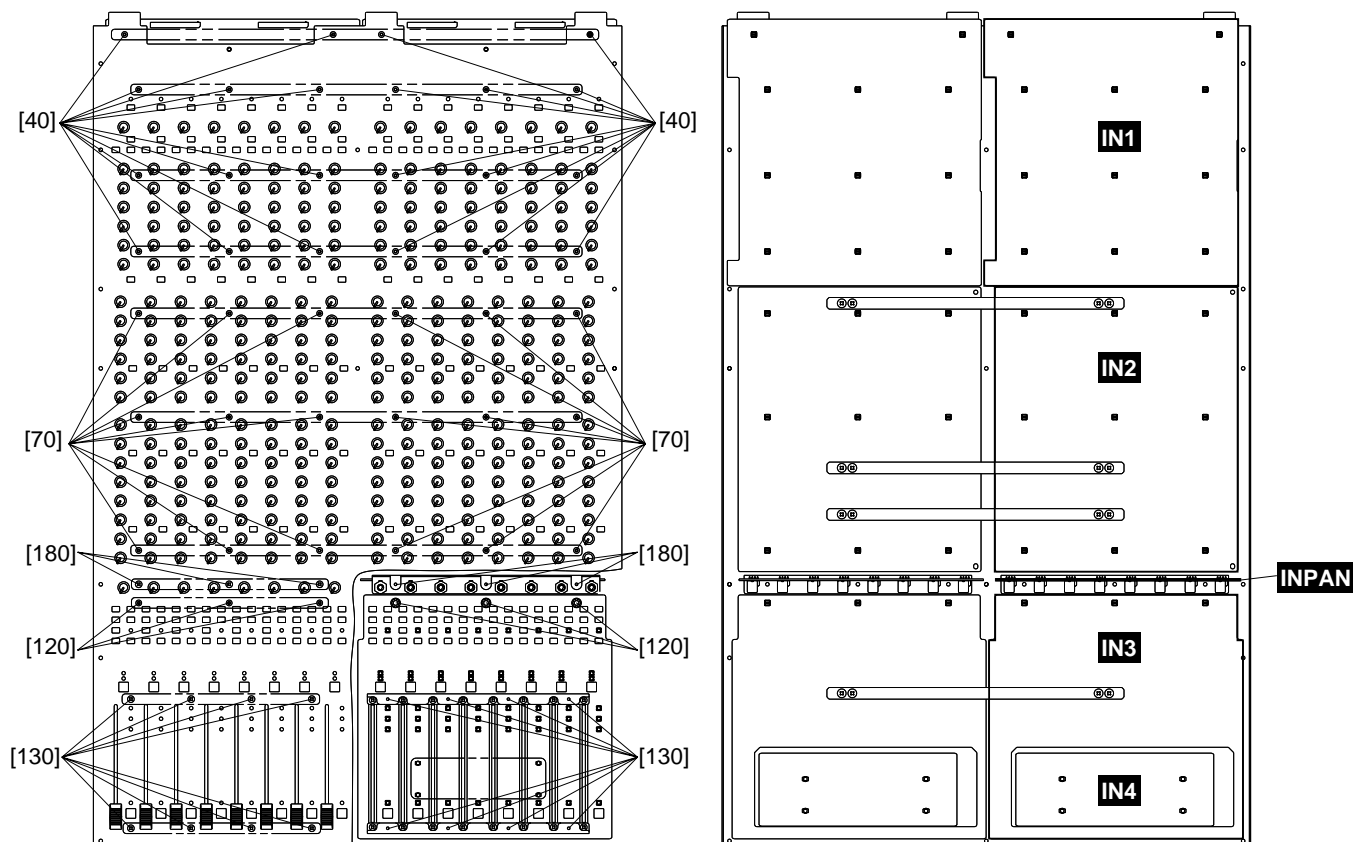

Fig.2

2 MASTER Assembly

- 2-1 Remove the meter panel. (See Procedure A1.)
- 2-2 Remove the MASTER assembly. (See Procedure A3.)
- 2-3 Remove the following circuit boards according to the listed order by removing the screws indicated for each of them. (Fig3)

Circuit Board & Unit	Ref No.	PARTS NAME	PARTS No.	Q'ty
ST1	60	Hexagon Socket Tapping Screw-P 3X25 MFZNBL	V3289800	8
ST2	90	Hexagon Socket Tapping Screw-P 3X25 MFZNBL	V3289800	6
ST3	150	Hexagon Socket Tapping Screw-P 3X25 MFZNBL	V3289800	2
	140	Bind Head Tapping Screw-B 3.0X8 MFZN2BL	EP600190	4
ST4	170	PCB Support CBS-6K		4

Circuit Board & Unit	Ref No.	PARTS NAME	PARTS No.	Q'ty
MAS1	220	Hexagon Socket Tapping Screw-P 3X25 MFZNBL	V3289800	12
MAS2 1/2	280	Hexagon Socket Tapping Screw-P 3X25 MFZNBL	V3289800	8
	270	Bind Head Tapping Screw-B 3.0X8 MFZN2BL	EP600190	6
MAS2 2/2	290	Bonding Tapping Screw-B 3.0X8 MFZN2BL	VN413300	2
MAS3 1/2	350	Hexagon Socket Tapping Screw-P 3X25 MFZNBL	V3289800	5
	340	Bind Head Tapping Screw-B 3.0X8 MFZN2BL	EP600190	10
MAS3 2/2		Nut		
MASSPAN 1/2	400	Bind Head Tapping Screw-B 3.0X8 MFZN2BL	EP600190	2
MASSPAN 2/2	400	Bind Head Tapping Screw-B 3.0X8 MFZN2BL	EP600190	2

Circuit Board & Unit	Ref No.	PARTS NAME	PARTS No.	Q'ty
CTRL 1/5-4/5	470	Bind Head Tapping Screw-B 3.0X8 MFZN2BL	EP600190	12
CTRL 5/5	110*1	Bonding Tapping Screw-B 3.0X8 MFZN2BL	VN413300	2

*1 OVERALL ASSEMBLY

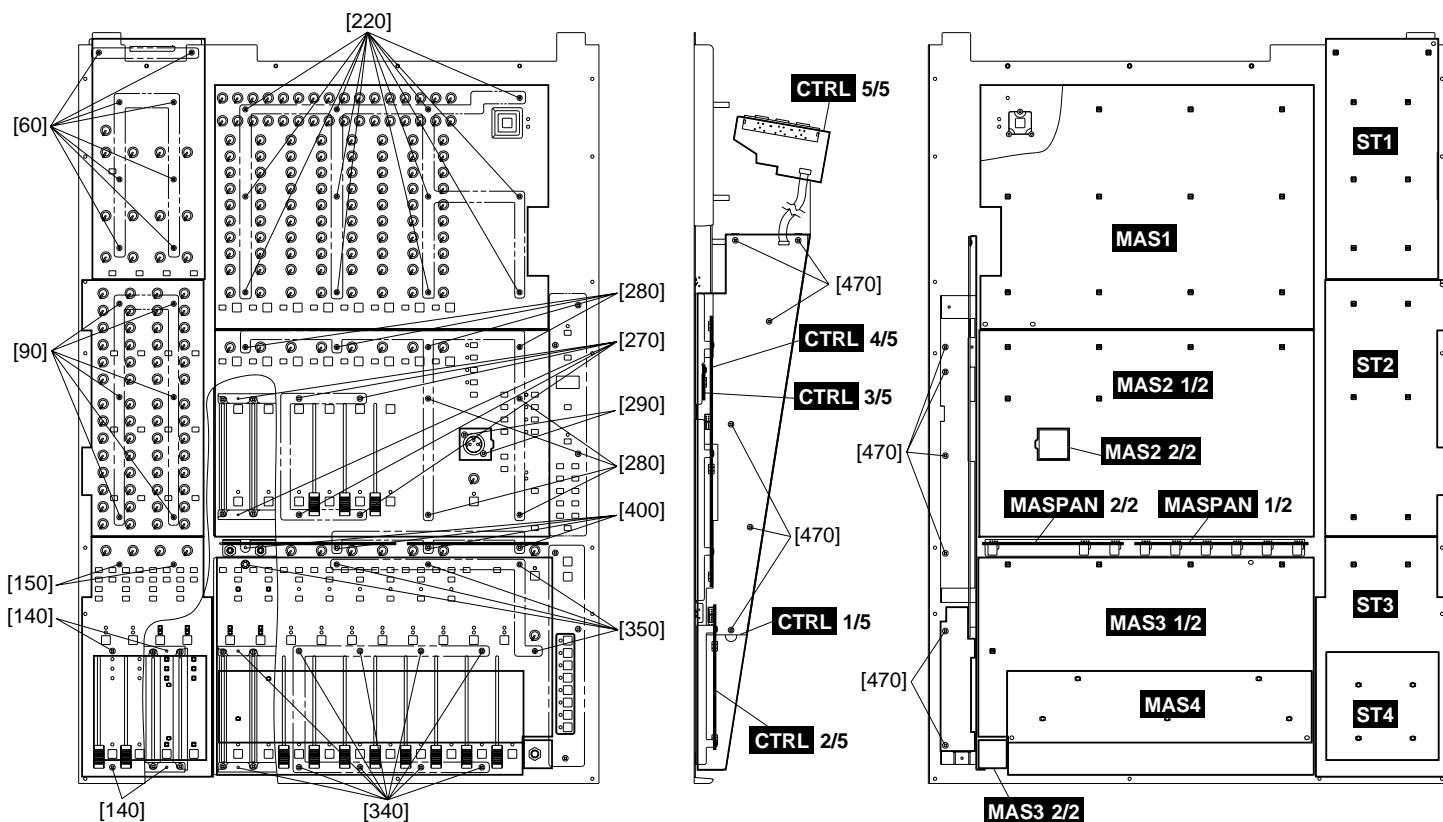
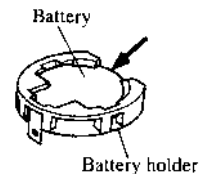

Fig.3

Battery VN103500

VN103600(Battery holder for VN103500)

- Notice for back-up battery removal
Push the battery as shows in figure, then the battery will pop up.
- Druk de batterij naar beneden zoals aangeven in de tekening, de batterij springt dan naar voren.



* Note that the battery is installed on the CTRL circuit board but it is not a component part.

3 MASOUT 1, 2, 3

- 3-1 Remove the meter panel. (See Procedure A1.)
- 3-2 Remove the MASTER assembly. (See Procedure A3.)
- 3-3 Remove the twelve (12) screws marked [30] from the rear panel. The MASOUT 1 circuit board can then be removed. (Fig. 4)
- 3-4 Remove the forty-eight (48) screws marked [50] from the rear panel. The MASOUT 2 circuit board can then be removed. (Fig. 4)
- 3-5 Remove the twelve (12) screws marked [70] from the rear panel. The MASOUT 3 circuit board can then be removed. (Fig. 4)

4 ISRT 1/6 ~ 6/6

- 4-1 Remove the meter panel. (See Procedure A1.)
- 4-2 Remove the MASTER assembly. (See Procedure A3.)
- 4-3 Remove the MONO assembly. (See Procedure A2.)
Remove the following circuit boards according to the listed order by removing the screws indicated for each of them.

Circuit Board & Unit	Ref No.	PARTS NAME	PARTS No.	Q'ty
ISRT 1/6	380	PCB Support CBS-6K GIN LIAN	VZ336600	4
ISRT 2/6	420	Bind Head Screw 4.0X8 MFZN2BL	EG340360	4
	440	Bind Head Screw 4.0X8 MFZN2BL	EG340360	4
	390	Bind Head Tapping Screw-B 3.0X8 MFZN2BL	EP600190	8
ISRT 3/6	440	Bind Head Screw 4.0X8 MFZN2BL	EG340360	4
	390	Bind Head Screw 4.0X8 MFZN2BL	EG340360	4
ISRT 4/6	390	Bind Head Screw 4.0X8 MFZN2BL	EG340360	4
ISRT 5/6	390	Bind Head Screw 4.0X8 MFZN2BL	EG340360	4
ISRT 6/6	390	Bind Head Screw 4.0X8 MFZN2BL	EG340360	1

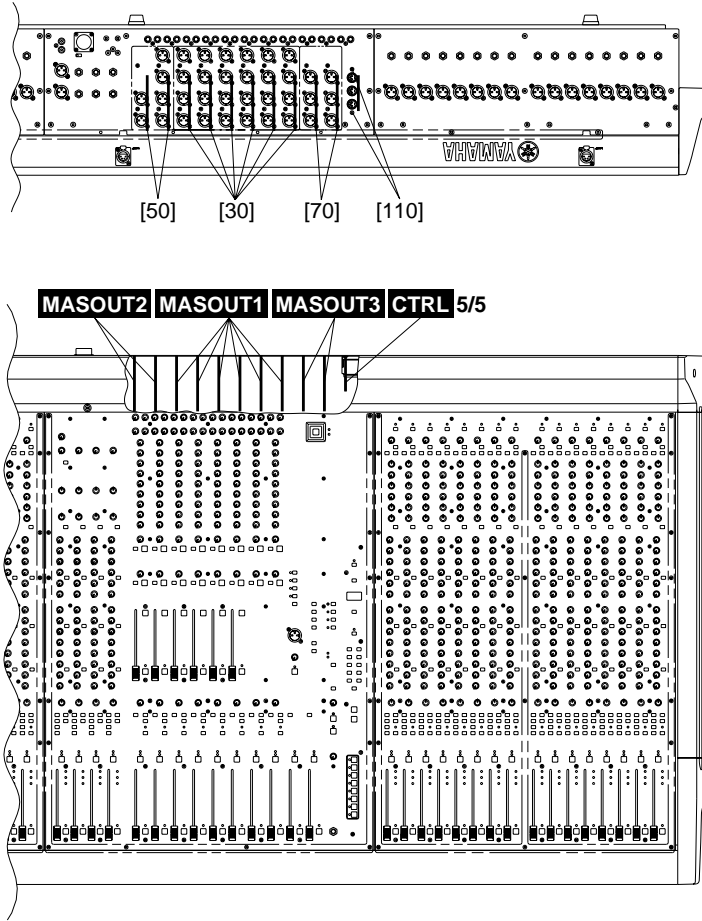

- [30]: Bonding Tapping Screw-B 3.0X8 MFZN2BL (VN413300)
- [50]: Bonding Tapping Screw-B 3.0X8 MFZN2BL (VN413300)
- [70]: Bonding Tapping Screw-B 3.0X8 MFZN2BL (VN413300)

Fig.4

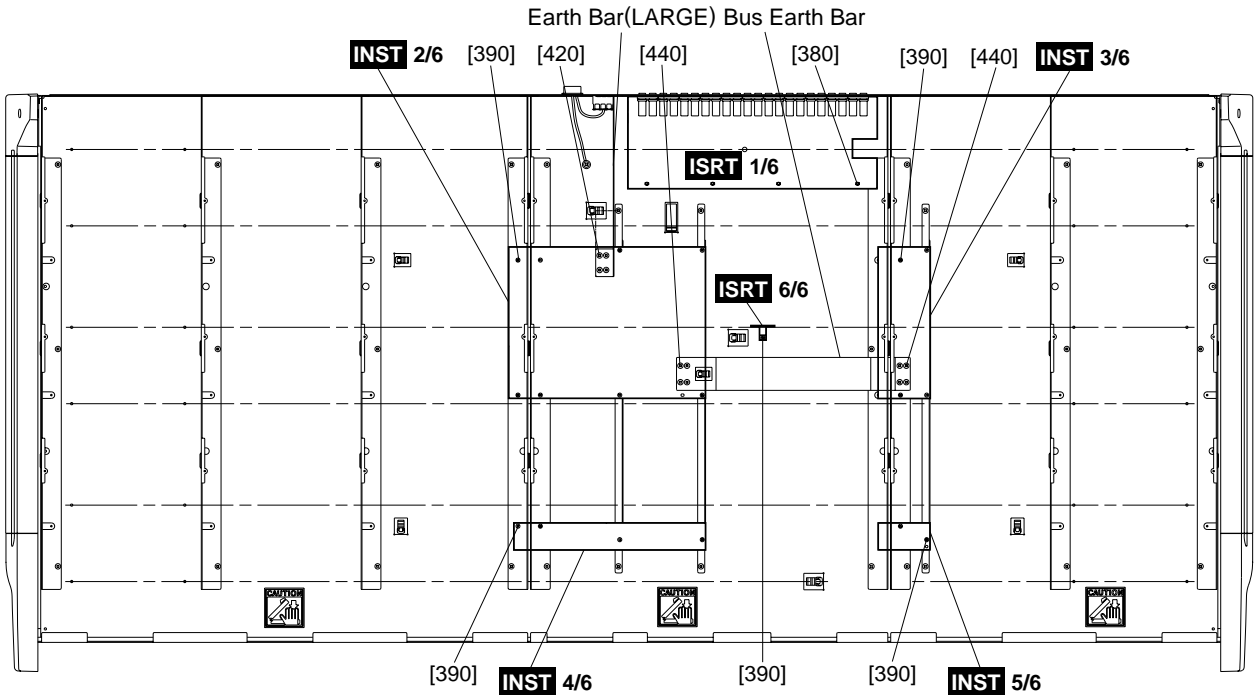

Fig.5

5 INJK

- 5-1 Remove the meter panel. (See Procedure A1.)
- 5-2 Remove the MONO assembly. (See Procedure A2.)
- 5-3 Remove the screws marked [460] and the hexagonalnuts marked [A] from the rear panel. The INJK can then be removed. (Fig. 6)

6 STJK

- 6-1 Remove the meter panel. (See Procedure A1.)
- 6-2 Remove the MASTER assembly. (See Procedure A3.)
- 6-3 Remove the two (2) screws marked [480] and the six (6) hexagonal nuts marked [B] from the rear panel. The STJK can then be removed. (Fig. 6)

7 Meter 1 and Meter 2

- 7-1 Remove the meter panel. (See Procedure A1.)
- 7-2 Remove the four (4) screws marked [80]. The Meters can then be removed. (Fig. 7)
- 7-3 Remove the Meter 1 1/3 to 3/3 circuit boards by removing the seven (7) screws marked [70]. (Fig. 7)
- 7-4 Remove the Meter 2 1/2 circuit board by removing the seven (7) screws marked [70]. (Fig. 7)
- 7-5 Remove the Meter 2 2/2 circuit board by removing the five (5) screws marked [70]. (Fig. 7)

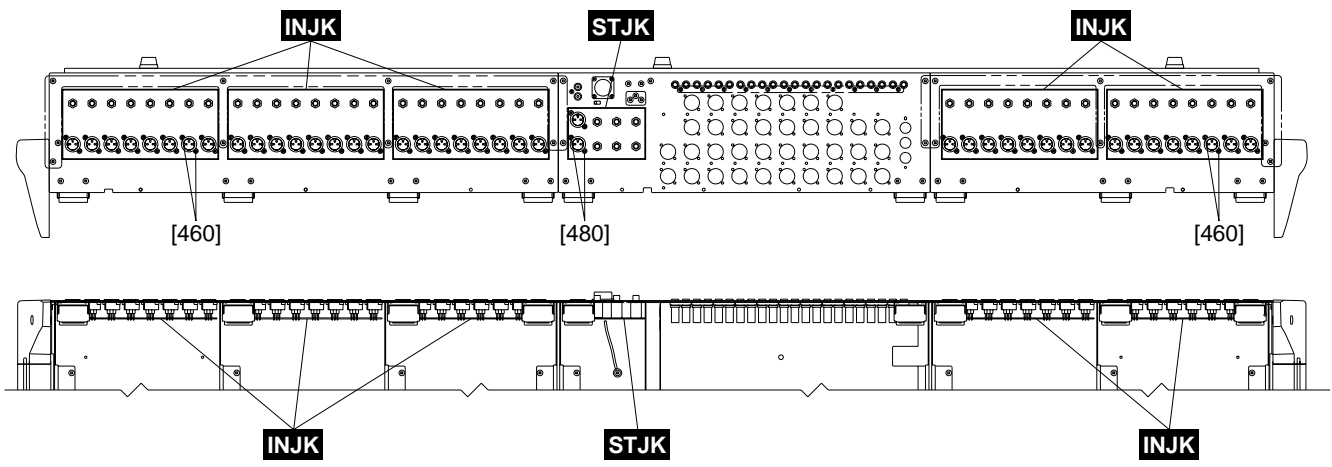

[460]: Bonding Tapping Screw-B 3.0X8 MFZN2BL (VN413300)
 [480]: Bonding Tapping Screw-B 3.0X8 MFZN2BL (VN413300)

Fig.6

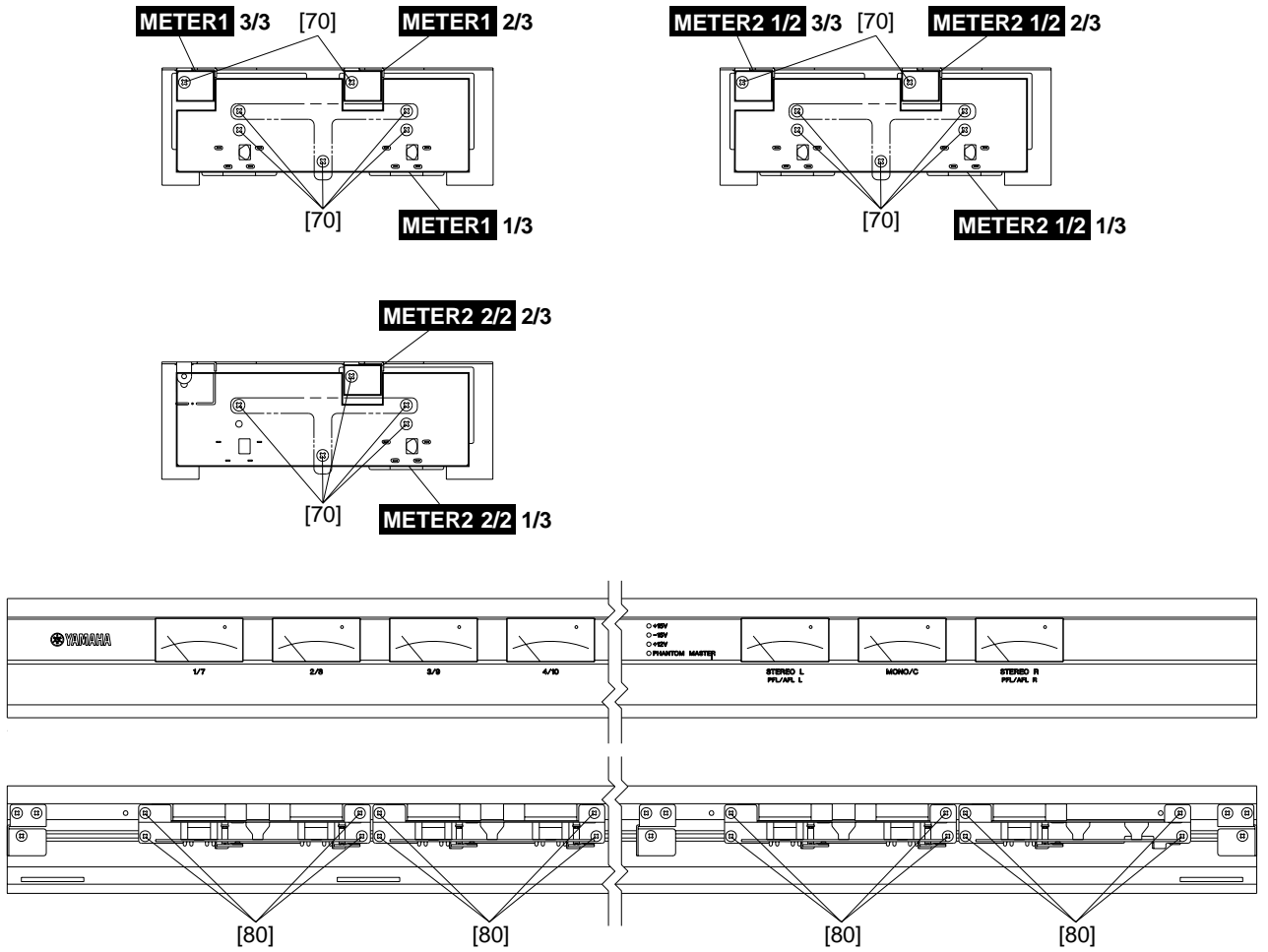

[70]: Bind Head Tapping Screw-B 3.0X8 MFZN2BL (EP600190)

Fig.7

LSI PIN DESCRIPTION

● HD6435208A00P (XK278A00) CPU <H8/520>

PIN No.	NAME	I/O	FUNCTION	PIN No.	NAME	I/O	FUNCTION
1	EXT	I	Clock	33	A7	O	Address bus
2	EXTAL	I		34	A8	O	
3	/WAIT	I	Bus cycle wait	35	A9	O	
4	/IRQ0	O	Interrupt request	36	A10	O	
5	A18	O		37	A11	O	
6	A17	O	Address bus	38	A12	O	
7	A16	O		39	A13	O	
8	/AS	O	Address strobe	40	A14	O	
9	/RD	O	Read strobe	41	A15	O	
10	/WR	O	Write strobe	42	AVCC		
11	VCC		Power supply	43	P50	O	
12	MD0	I		44	P51	O	Port 5
13	MD1	I	Mode select	45	P52	O	
14	MD2	I		46	P53	O	
15	/RES	I	Reset	47	P54	O	
16	NMI	I	Non-maskable interrupt request	48	P55	O	
17	VSS		Ground	49	P56	O	Ground
18	D0	I/O		50	P57	O	
19	D1	I/O		51	VSS		
20	D2	I/O	Data bus	52	AVSS		
21	D3	I/O					
22	D4	I/O					
23	D5	I/O					
24	D6	I/O					
25	D7	I/O					
26	A0	O			53	AN0	I
27	A1	O		54	AN1	I	
28	A2	O		55	AN2	I	
29	A3	O	Address bus	56	AN3	I	
30	A4	O		57	AVCC		Analog power supply
31	A5	O		58	TXD2	O	
32	A6	O		59	RXD2	I	Receive data
				60	A19	O	Address bus
				61	TXD1	O	Transmit data
				62	RXD1	I	Receive data
				63	SCLK	I	Clock for serial operation
				64	VSS		Ground

● AK4320-VM-E1 (XR361A00) DAC

PIN No.	NAME	I/O	FUNCTION	PIN No.	NAME	I/O	FUNCTION
1	CKS	I	Clock select	13	DEM1	I	De-emphasis mode
2	DVDD		Digital VDD	14	DIF0	I	
3	DVSS		Digital GND	15	DIF1	I	Input format
4	XTO	O	Xtal out	16	VCNT	I	Mute Control
5	XTI	I	Xtal in	17	AOUTR	O	Analog output R
6	/PD	I	Power down	18	AOUTL	O	Analog output L
7	BICK	I	Serial bit clock	19	VCOM	O	Common
8	SDATA	I	Serial data input	20	AVDD		Analog VDD
9	LRCK	I	L/R clock	21	AVSS		Analog VSS
10	SMUTE	I	Soft mute	22	VREF	I	V reference
11	HOLD	I	Soft mute hold	23	DZF	O	Zero input
12	DEMO	I	De-emphasis mode	24	ZMUTE	I	Zero mute

● LZ95300 (XP451A00) Gate Array

PIN NO.	NAME	I/O	FUNCTION	PIN NO.	NAME	I/O	FUNCTION
1	INC	O	INPUT CUE ON/OFF	15	/CSW	I	CUE switch input
2	CPR	O	VCA CUE PRE PAN ON/OFF	16	VCA8	I	VCA GROUP switch input
3	CPST	O	VCA CUE POST PAN ON/OFF	17	VCA7	I	
4	COFF	O	All CUE OFF	18	VCA6	I	
5	CPU	I	H: CPU mode, L: Local mode	19	VCA5	I	
6	C0	I	CPU address bus	20	VCA4	I	
7	C1	I					
8	C2	I					
9	C3	I					
10	/RES	I	Reset	24	/SLSF	I	SOLO SAFE switch input
11	DATA	I/O	Data input/output	25	/CHK	I	CHECK LED ON/OFF
12	IRQ	O	When /ONSW and /CSW change; H. When CPU reads data; L.	26	/ONSW	I	ON switch input
13	/CS	I	Chip select	27	/ONRY	O	ON relay & LED ON/OFF
14	GND		Digital ground	28	VDD		Digital power supply

● Function of DATA

C3	C2	C1	C0	R/W	MODE	FUNCTION	DATA	
							0	1
0	0	0	0	W	ON RELAY SET	Sets /ONRY	OFF	ON
0	0	0	1	R	ON SW READ	Reads /ONSW	OFF	ON
0	0	1	0	W	CUE RELAY SET	Sets INC ON	OFF	ON
0	0	1	1	R	CUE SW READ	Reads /CSW	OFF	ON
0	1	0	0	W	CHECK LED SET	Sets /CHK	OFF	ON
0	1	0	1	W	VCA PRE/POST SET	Sets CVCA CUE PRE/POST PAN	POST	PRE
0	1	1	0	W	SOLO SET	Sets SOLO When SOLO is set, CUE or SOLO SAFE is not ON, /ONRY is set to OFF.	OFF	SOLO
0	1	1	1	W	VCA1 CUE SET	Sets VCA1 CUE	OFF	ON
1	0	0	0	W	VCA1 CUE SET	Sets VCA1 CUE	OFF	ON
1	0	0	1	W	VCA2 CUE SET	Sets VCA2 CUE	OFF	ON
:	:	:	:	:	:	:	:	:
:	:	:	:	:	:	:	:	:
1	1	1	1	W	VCA8 CUE SET	Sets VCA8 CUE	OFF	ON

● YSP99 LZ95XD59 (XM047A00) Gate Array

PIN NO.	NAME	I/O	FUNCTION	PIN NO.	NAME	I/O	FUNCTION	
1	NC			41	A9	I	CPU address bus	
2	MCLK	O	Master clock	42	A8	I		
3	DESYN	O	Sync for DEQIC	43	CD2	I	CARD page select	
4	CD04	I	Control data input	44	CD1	I		
5	CD03	I		CARD/ROM select	45	CDROM	I	
6	CD02	I			ROM page control	46	ROM4	I
7	CD01	I		ROM2		47	ROM3	I
8	CD14	O				ROM1	48	ROM2
9	CD13	O	Control data output (DSP2)	49	ROM1	I	Dividing select	
10	CD12	O	Control data output (MOD)	50	YY2	I		
11	CD11	O	Control data output (DEQ IC17)	51	YY1	I		
12	+Vdd		Control data output (DEQ IC19)	52	GND		Control data select	
13	GND			53	+Vdd			
14	L4	O	LED scan pulse	54	SEL2	I		
15	L3	O		LED scan data	55	SEL1		I
16	L2	O			MIDI clock	56		XX2
17	L1	O		Trigger out		57	XX1	I
18	LCD	O			LCD enable	58	MDCK	O
19	KEYN	O	KEY enable	59	TRG0	O		
20	LED	O	LED enable	60	E	I	Read write pulse	
21	CDA14	O	CARD address	61	RWN	I		
22	CDA13	O		CARD enable	62	ICN	I	Initial clear
23	CARDN	O		63	ACIA	O	ACIA enable	
24	GND			64	GND		DSP control data input	
25	RAWN	O	RAM write enable	65	TXD	I		
26	RAON	O	RAM read enable	66	RXD	O	DSP control data output	
27	RMA16	O	ROM address back select	67	XCLK	O	Transfer clock	
28	RMA15	O		Word clock	68	WCLK	O	
29	RMA14	O			Serial data transfer clock 64fs	69	SCLK	O
30	RMA13	O		NC		70	FSYNC	O
31	+Vdd				71	ADLR	O	NC
32	GND			72	GND		Serial data sift clock	
33	ROMN	O	ROM read enable	73	+Vdd			
34	A15	I	CPU address bus	74	SCLKN	O	256fs clock	
35	A14	I		Clock input/(Xtal)	75	DCLK	O	
36	A13	I			output/(Xtal)	76	XI	I
37	A12	I		Trigger input		77	XO	O
38	A11	I			Sync clock	78	GND	
39	A10	I		79		TRIG	I	
40	NC			80	SYNEN	O		

● YSS228E-F (XQ962D00) DSP3 (Digital Signal Processor)

DM : IC2, 3

PIN NO.	NAME	I/O	FUNCTION	PIN NO.	NAME	I/O	FUNCTION	
1	VSS		Ground	81	VSS	I/O	Ground	
2	XI	I	System master clock input (60 M or 30 MHz)	82	DB13	I/O	Ground	
3	XO		System master clock input (60 M or 30 MHz)	83	DB14	I/O		
4	VDD		Power supply	84	DB15	I/O		
5	/SYNCI	I	System synch. input	85	DB16	I/O		
6	/SYNCO	O	System synch. output	86	DB17	I/O		
7	CKI	I	System clock input (30 MHz)	87	DB18	I/O		
8	CKO	O	System clock output (30 MHz)	88	DB19	I/O		
9	CKSL	I	System master clock select (0:60 M,1:30 MHz)	89	DB20	I/O		
10	VSS		Ground	90	DB21	I/O		
11	MCKS	I	Master clock for serial I/O(128 xFs)	91	DB22	I/O		Parallel data bus
12	/SSYNC	I	Synch. signal for serial I/O	92	DB23	I/O		
13	/IC	I	Initial clear	93	DB24	I/O		
14	/TEST	I	Test mode setting	94	DB25	I/O		
15	BTYP	I	CPU data bus 8/16 bit select(0:8,1:16)	95	DB26	I/O		
16	/IRQ	O	Interrupt request	96	DB27	I/O		
17	TRIG	I/O	Trigger signal	97	DB28	I/O		
18	VDD		Power supply	98	DB29	I/O		
19	VSS		Ground	99	DB30	I/O		
20	/CS	I	Chip select	100	DB31	I/O		
21	/DS	I	Data strobe	101	TIMO/DBOE	I/O	Timing signal/Parallel data bus control	
22	R/W	I	Read/Write select	102	VSS			Ground
23	CA7	I	CPU address bus	103	VDD		Power supply	
24	CA6	I						
25	CA5	I						
26	CA4	I						
27	CA3	I						
28	CA2	I						
29	CA1	I						
30	CA0/CD15	I/O	CPU address/data bus	104	DA00	I/O	External memory data bus	
31	CD14	I/O						
32	CD13	I/O						
33	CD12	I/O						
34	CD11	I/O	CPU data bus	105	DA01	I/O		
35	CD10	I/O						
36	CD09	I/O						
37	CD08	I/O						
38	CD07	I/O						
39	CD06	I/O						
40	VSS			Ground	106	DA02	I/O	
41	VDD		Power supply	107	DA03	I/O		
42	CD05	I/O	CPU data bus	108	DA04	I/O		
43	CD04	I/O						
44	CD03	I/O						
45	CD02	I/O						
46	CD01	I/O						
47	CD00	I/O						
48	/DTACK	O		DTACK signal output	109	DA05	I/O	
49	SI0	I	Serial data input	110	DA06	I/O		
50	SI1	I						
51	SI2	I						
52	SI3	I						
53	SI4	I						
54	SI5	I						
55	SI6	I						
56	SI7	I						
57	VSS		Ground	111	DA07	I/O		
58	VDD		Power supply	112	DA08	I/O		
59	SO0	O	Serial data output	113	DA09	I/O		
60	SO1	O						
61	SO2	O						
62	SO3	O						
63	SO4	O						
64	SO5	O						
65	SO6	O						
66	SO7	O						
67	DB00	I/O	Parallel data bus	114	DA10	I/O		
68	DB01	I/O						
69	DB02	I/O						
70	DB03	I/O						
71	DB04	I/O						
72	DB05	I/O						
73	DB06	I/O						
74	DB07	I/O						
75	DB08	I/O						
76	DB09	I/O						
77	DB10	I/O						
78	DB11	I/O	External memory address bus	115	DA11	I/O		
79	DB12	I/O						
80	VDD			Power supply	116	DA12	I/O	
					117	DA13	I/O	
				118	DA14	I/O	Ground	
				119	DA15	I/O		
				120	VSS		Power supply	
				121	VDD			
				122	DA16	I/O	External memory data bus	
				123	DA17	I/O		
				124	DA18	I/O		
				125	DA19	I/O		
				126	DA20	I/O		
				127	DA21	I/O		
				128	DA22	I/O		
				129	DA23	I/O		
				130	DA24	I/O		
				131	DA25	I/O		
				132	DA26	I/O		
				133	DA27	I/O	Ground	
				134	DA28	I/O		
				135	DA29	I/O	Power supply	
				136	DA30	I/O		
				137	DA31	I/O	External memory address bus	
				138	VDD			
				139	VSS			
				140	A00	O		
				141	A01	O		
				142	A02	O		
				143	A03	O		
				144	A04	O		
				145	A05	O		
				146	A06	O		
				147	A07	O		
				148	A08	O		
				149	A09	O		
				150	A10	O		
				151	A11	O		
				152	A12	O		
				153	A13	O		
				154	A14	O		
				155	A15/RAS	O	External memory address bus/Row address strobe	
				156	A16/CAS	O		External memory address bus/Column address strobe
				157	A17/CE	O		
				158	/WE	O		External memory write enable
				159	/OE	O	External memory output enable	
				160	VDD		Power supply	

IC BLOCK DIAGRAM

- **BA6144** (XA552A00)
ST4: IC121,IC221,IC321,IC421
IN3: IC103,IC203,IC303,IC403,
IC503,IC603,IC703,IC803

METER DRIVER

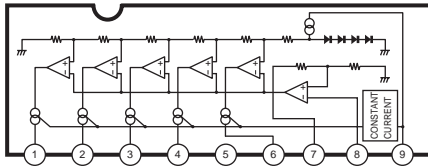

- **NJM2068-D**(XM356A00)
ST1: IC101~106,IC201~204,
IC301~305,IC401~404
MAS3: IC952,IC953
MAS2: IC101,IC151,IC301,IC351,IC501,
IC551,IC751,IC901~903
MAS1: IC101~103,IC301~303,IC501~503,
IC701~703
ISRT: IC101~104,IC111~115,IC121~124,
IC201~217
IN1: IC103~107,IC303~307,IC503~507,
IC703~707

- **NJM2082M(T1)**(XN797A00)
CTRL: IC108

- **NJM4558L-D**(XQ212A00)
METER1: IC102
METER2: IC102

OP AMP

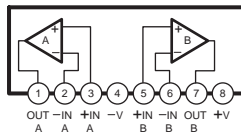

- **NJM4556AL**(XP844A00)
MAS: IC951

- **NJM4580L**(XF195A00)
ST2: IC101~103,IC301~303
ST3: IC101,IC201,IC301,IC401
MASOUT3: IC101,IC201,IC301
MSOUT1,2: IC301,IC201,IC301,IC401
MAS3: IC101,IC301,IC501,IC701,
IC901,IC902
MAS1: IC901
IN3: IC101,IC102,IC301,IC501,IC502,
IC701,IC702
IN1: IC101,IC102,IC301,IC501,IC502,
IC701,IC702

- **M5238AP**(XM085A00)
DC: IC101,IC201,IC202

OP AMP

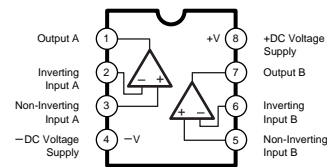

- **SN74HC00NSR** (XE165A00)
CTRL: IC113

NAND

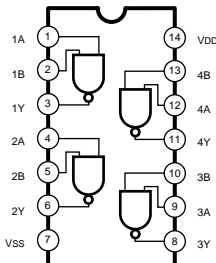

- **SN74HC04NSR** (XD830A00)
CTRL: IC109

INVERTER

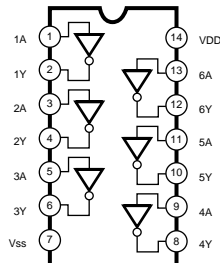

- **SN74HC138NSR** (XD835A00)
CTRL: IC124

DECODER

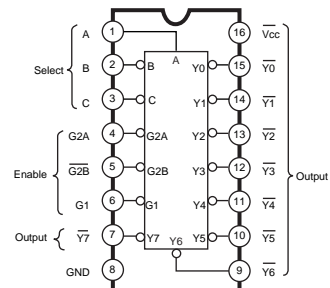

- **SN74HC14NSR** (XC725A00)
CTRL: IC110,IC302

INVERTER

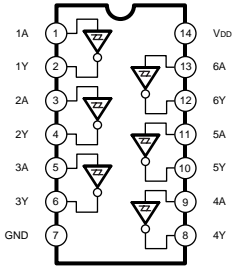

- **SN74HC174NSR** (XD836A00)
CTRL: IC123

D-FF

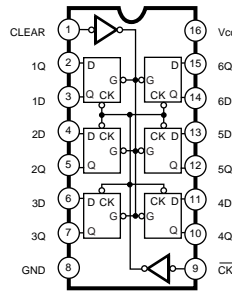

- **SN74HC245NSR** (XD838A00)
CTRL: IC121,IC125,IC131

BUFFER

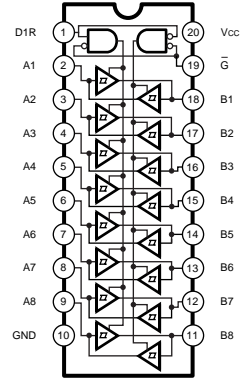

- **SN74HC273NSR** (XH223A00)
CTRL: IC132

D-FF

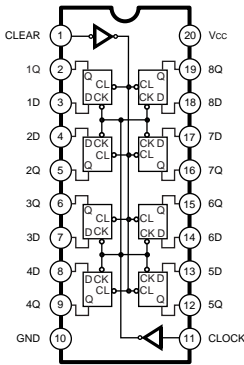

- **SN74HC32NSR** (XD833A00)
CTRL: IC112

OR

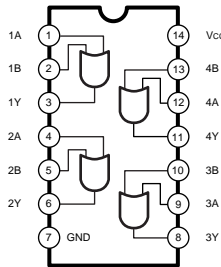

- **SN74HC374ANSR** (XQ042A00)
CTRL: IC122

D-FF

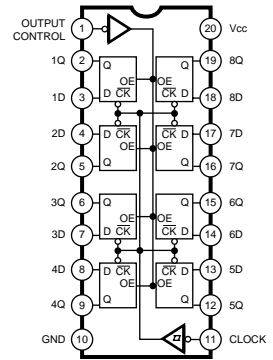

- **TC4052BP** (XA053A00)
METER1: IC101
METER2: IC101
MULTIPLEXER

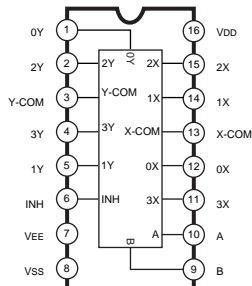

- **SN74HC02AP** (IR000200)
ST4: IC102 MAS4: IC102,502,902
IN4: IC102,IC302
NOR

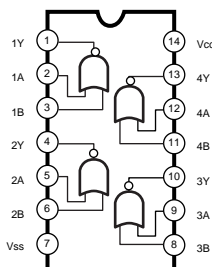

- **SN74HC139AP** (IR013900)
MAS2: IC910
DECODER

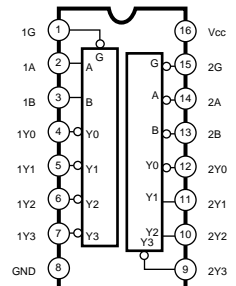

■ CIRCUIT BOARDS

■ CONTENTS

MASOUT1 Circuit Board	34
MASOUT2 Circuit Board	35
MASOUT3 Circuit Board	36
METER1 Circuit Board	37
METER2 Circuit Board	37
METER3 Circuit Board	37
CTRL 1/5 Circuit Board	38
CTRL 2/5 Circuit Board	38
CTRL 3/5 Circuit Board	38
CTRL 4/5 Circuit Board	38
CTRL 5/5 Circuit Board	38
IN1 Circuit Board	40
IN2 Circuit Board	42
IN3 Circuit Board	44
IN4 Circuit Board	46
IN JK Circuit Board	47
IN PAN Circuit Board	47
ISRT 1/6 Circuit Board	48
ISRT 2/6 Circuit Board	49
ISRT 3/6 Circuit Board	49
ISRT 4/6 Circuit Board	48
ISRT 5/6 Circuit Board	48
ISRT 6/6 Circuit Board	48
MAS1 1/2 Circuit Board	48
MAS1 2/2 Circuit Board	48
MAS2 1/2 Circuit Board	52
MAS2 2/2 Circuit Board	52
MAS3 1/2 Circuit Board	54
MAS3 2/2 Circuit Board	54
MAS4 Circuit Board	56
MAS PAN Circuit Board	56
ST1 Circuit Board	57
ST2 Circuit Board	58
ST3 Circuit Board	59
ST4 Circuit Board	60
STJK 1/2 Circuit Board	60
STJK 2/2 Circuit Board	60

Note : See parts list for details of circuit board component parts.

• MASOUT1 Circuit Board

- CN321: (AUX OUT 326)
- MAS2-CN205
(AUX/GRP OUT A7/G1~A10/G4)
- MAS2-CN206
(AUX/GRP OUT A11/G5~A14/G8)
- MAS2-CN207
(GRP/AUX OUT G1/A7~G4/A10)
- MAS3-CN308
(GRP/AUX OUT G5/A11~G8/A14)
- MAS3-CN309
(MATRIX OUT 1~4)
- MAS1-CN101
(MATRIX OUT 5~8)
- MAS1-CN102

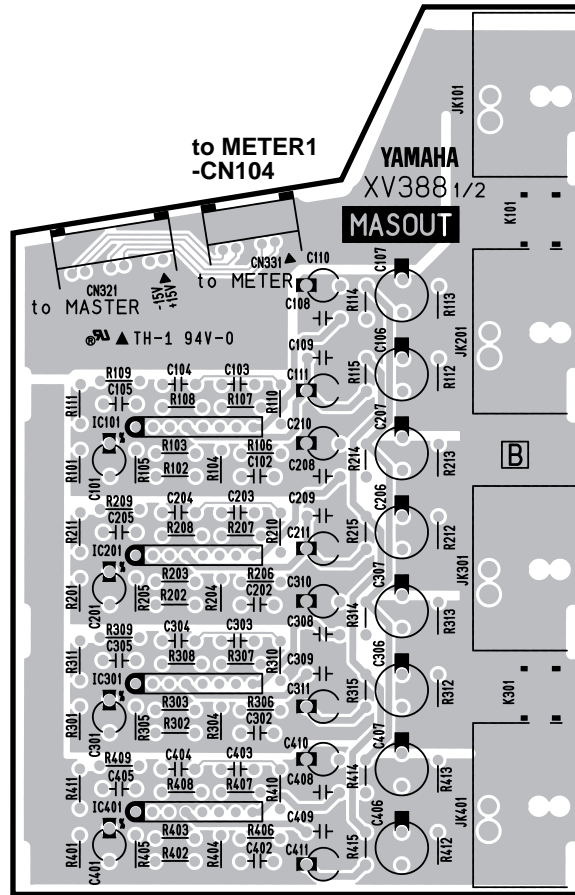

MATRIX OUT (5, 1)
AUX/GRP OUT (A11/G6, A7/G1)
GRP/AUX OUT (G5/A11, G1/A7)
AUX OUT (3)

MATRIX OUT (6, 2)
AUX/GRP OUT (A12/G6, A8/G2)
GRP/AUX OUT (G6/A12, G2/A8)
AUX OUT (4)

MATRIX OUT (7, 3)
AUX/GRP OUT (A13/G7, A9/G3)
GRP/AUX OUT (G7/A13, G3/A9)
AUX OUT (5)

MATRIX OUT (8, 4)
AUX/GRP OUT (A14/G8, A10/G4)
GRP/AUX OUT (G8/A14, G4/A10)
AUX OUT (6)

Component side

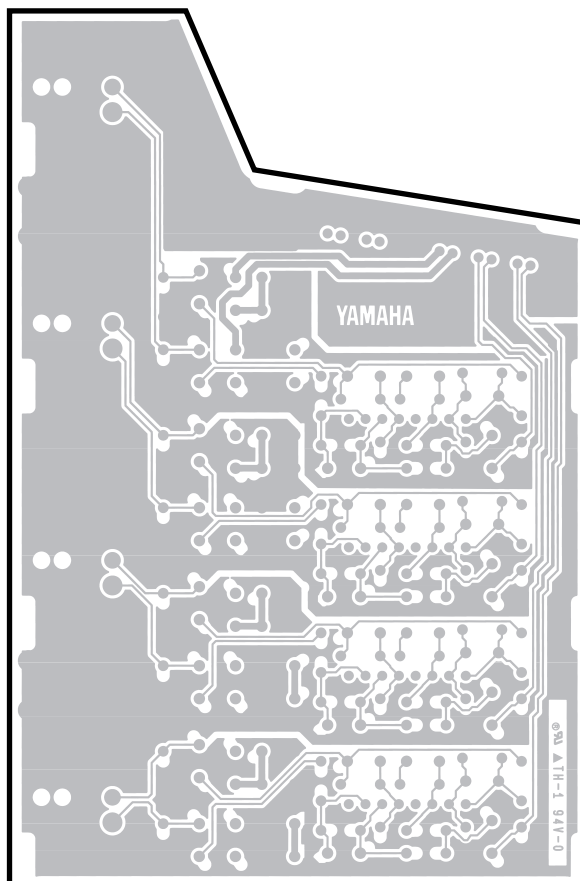

Pattern side

MASOUT1 : 3NA-V230710

• MASOUT2 Circuit Board

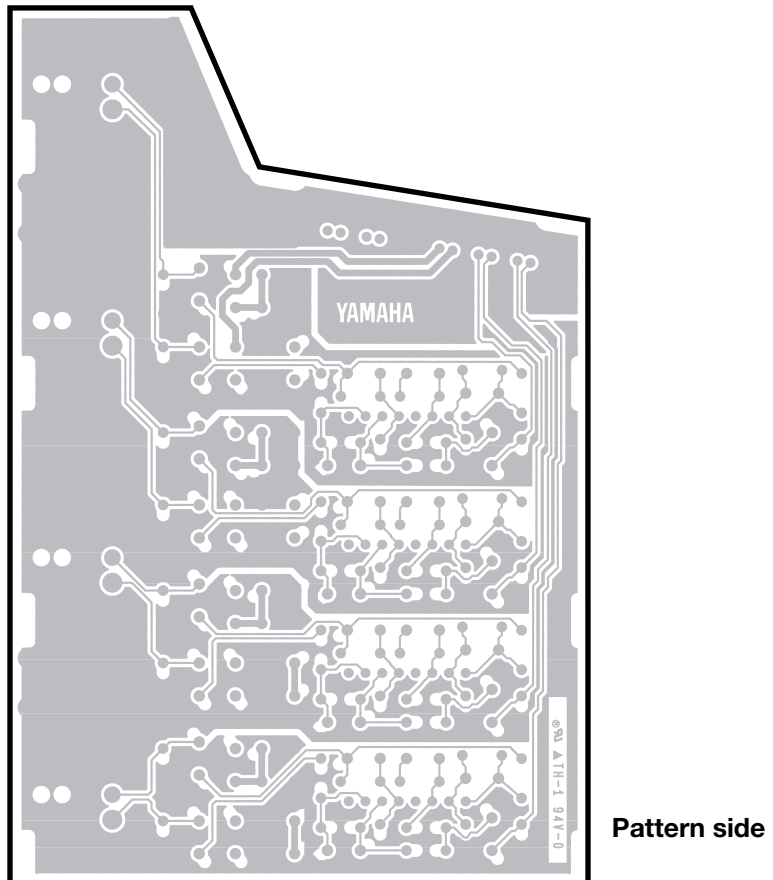
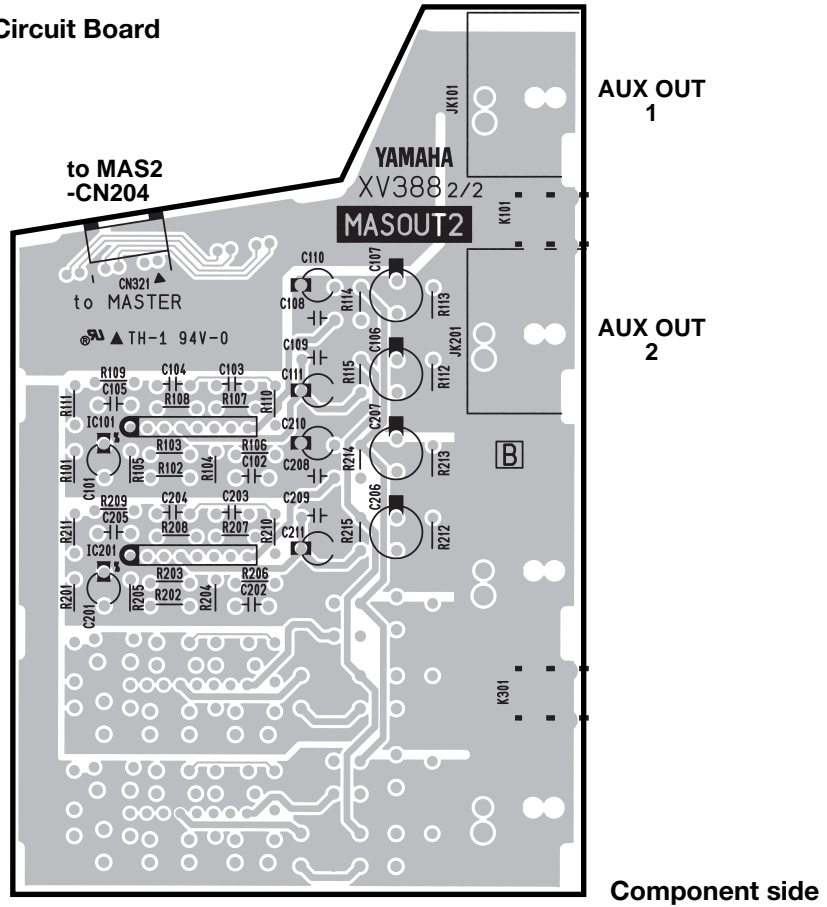

• MASOUT3 Circuit Board

to MAS3-CN310 (ST OUT)
to MAS3-CN321 (MON1)

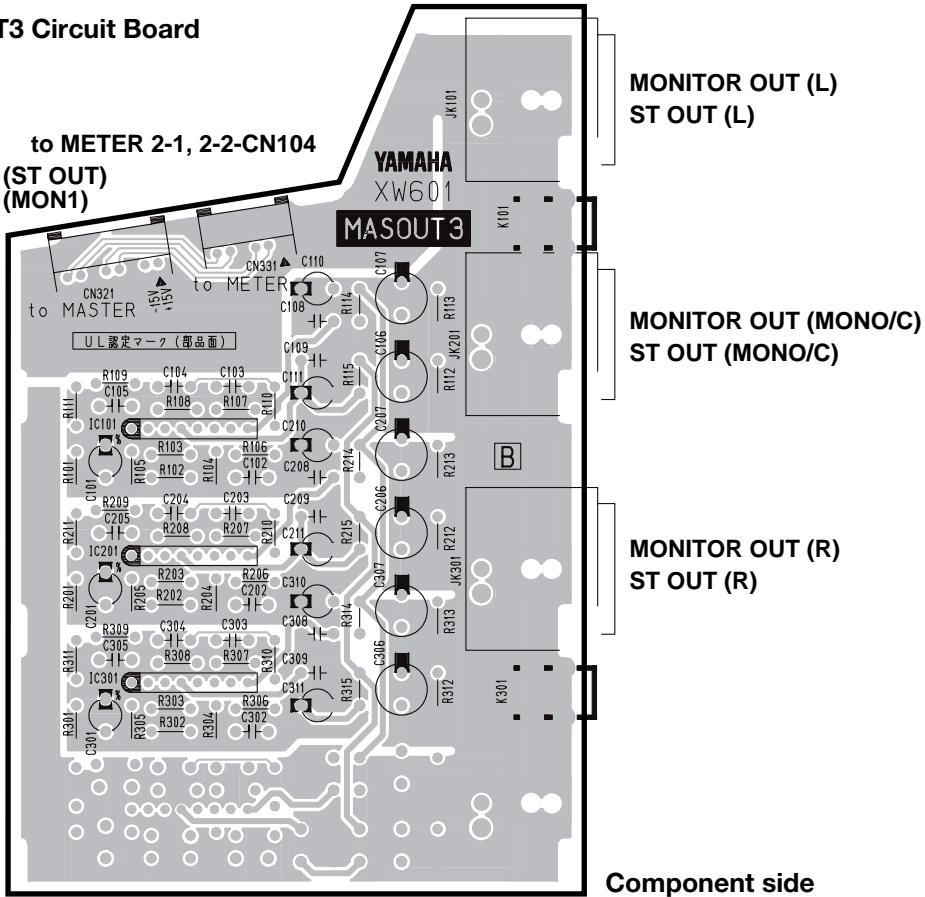

Component side

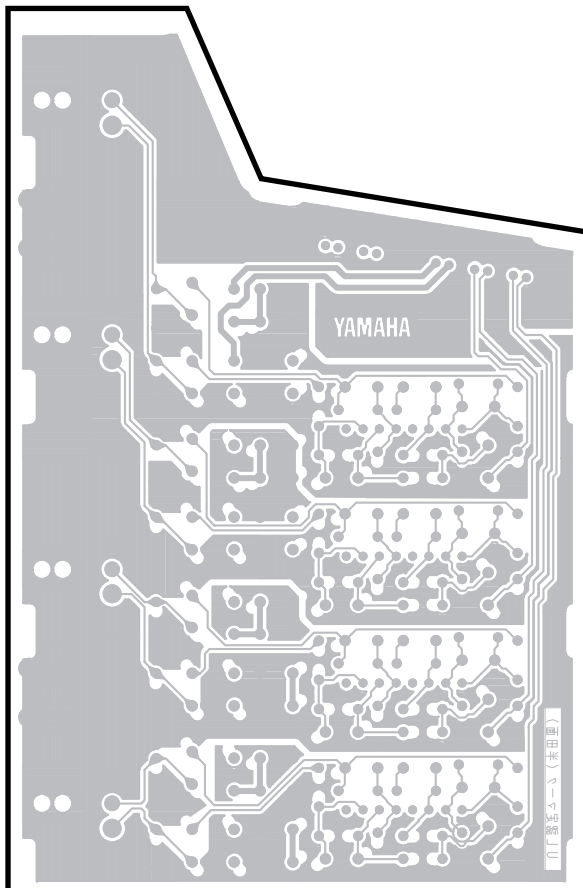

Pattern side

MASOUT3 : 3NA-V431500

• METER1 Circuit Board

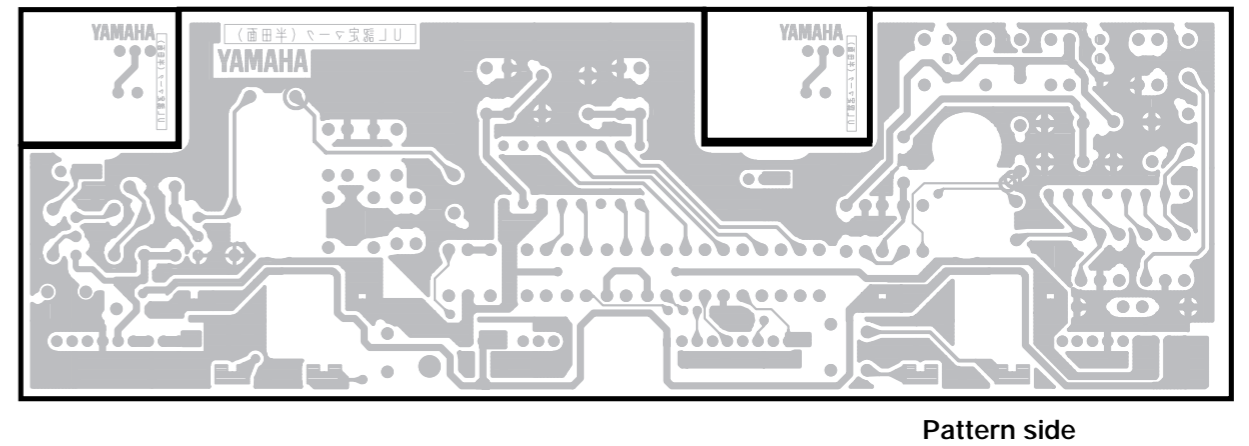
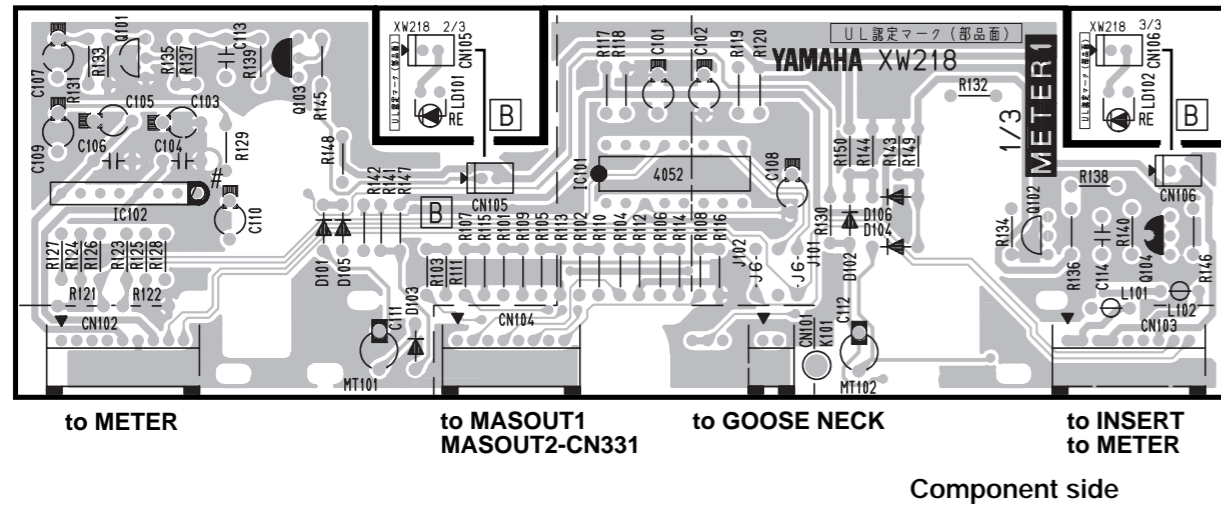

• METER2-1 Circuit Board

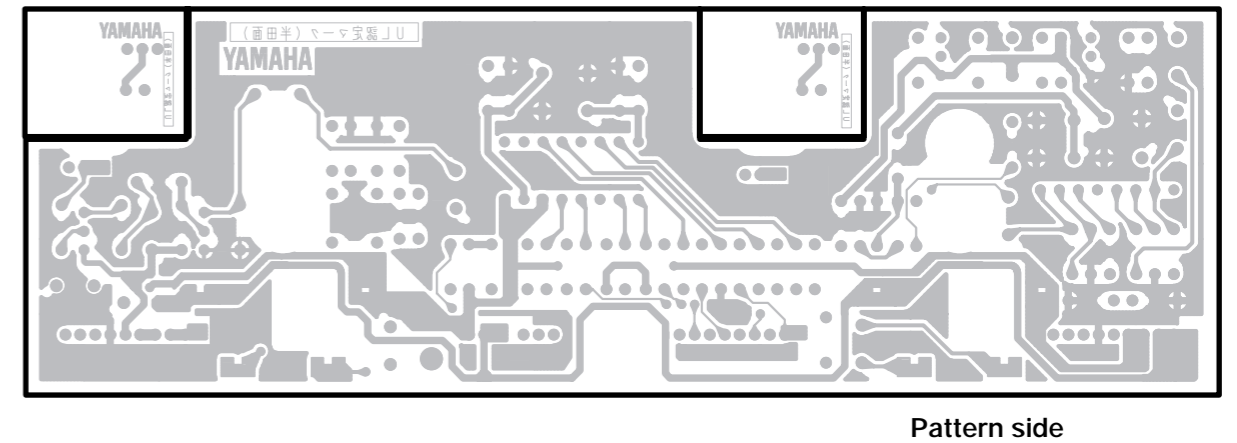
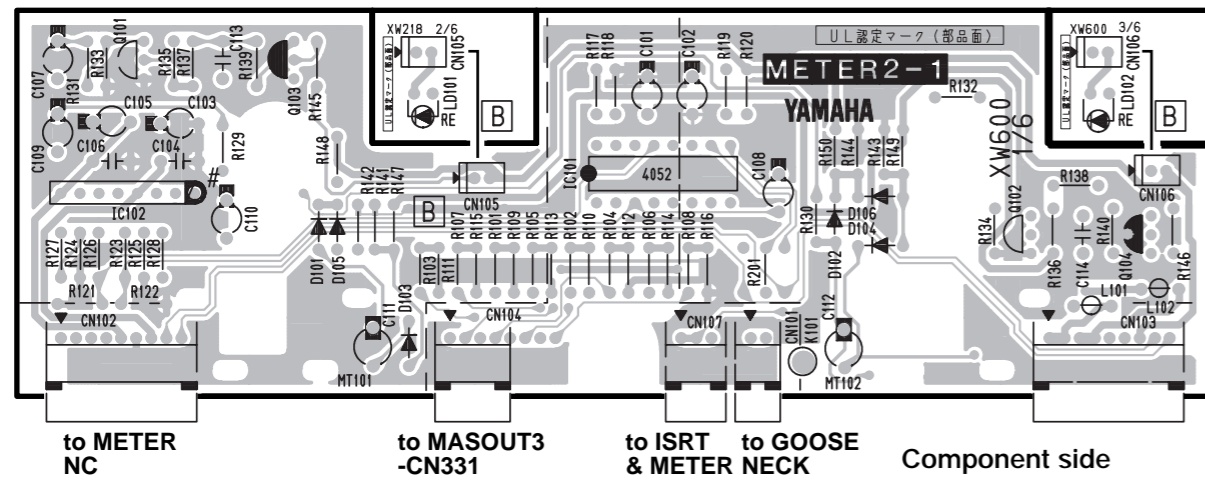

• METER2-2 Circuit Board

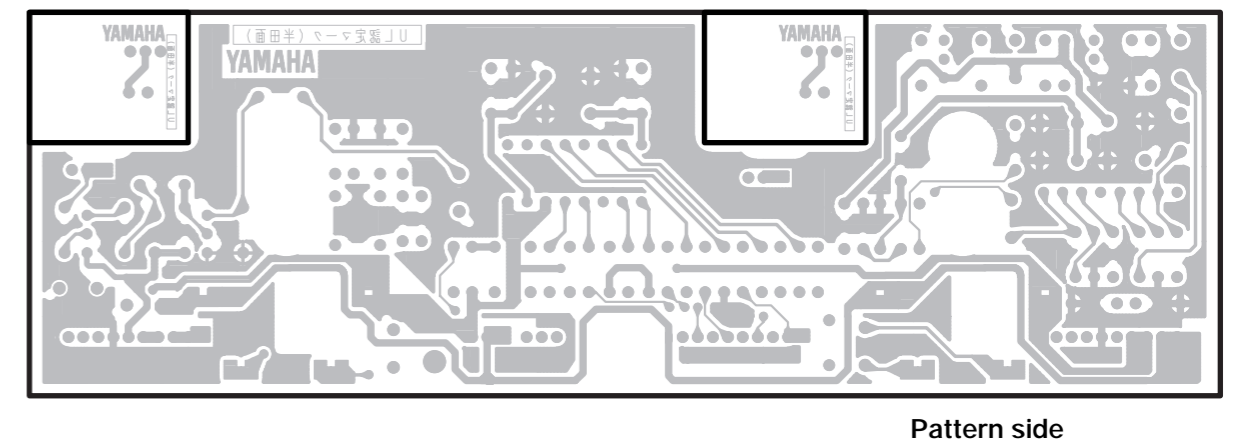
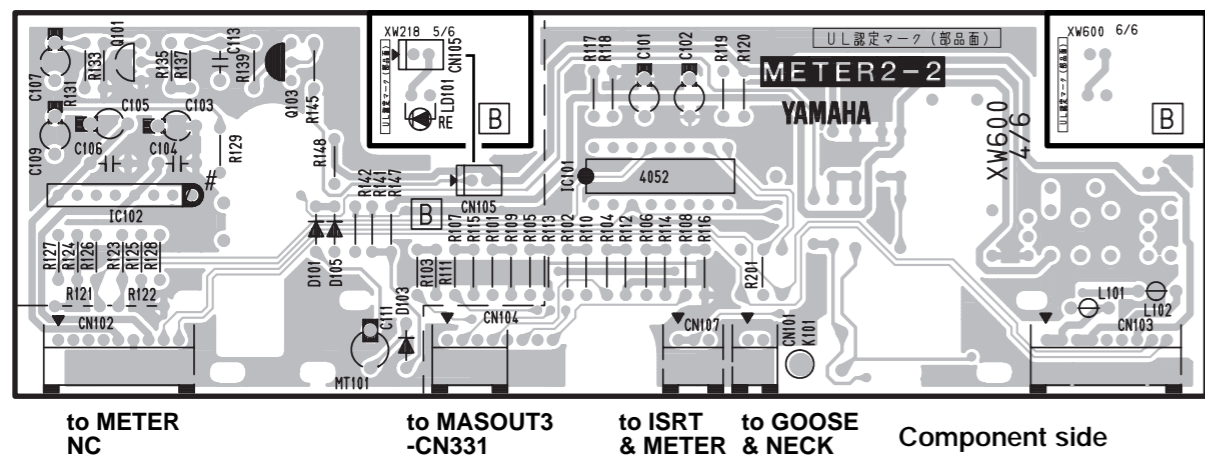

- METER1: 3NA-V431480
- METER2-1: 3NA-V431490
- METER2-2: 3NA-V431490

• CTRL Circuit Board 1/5

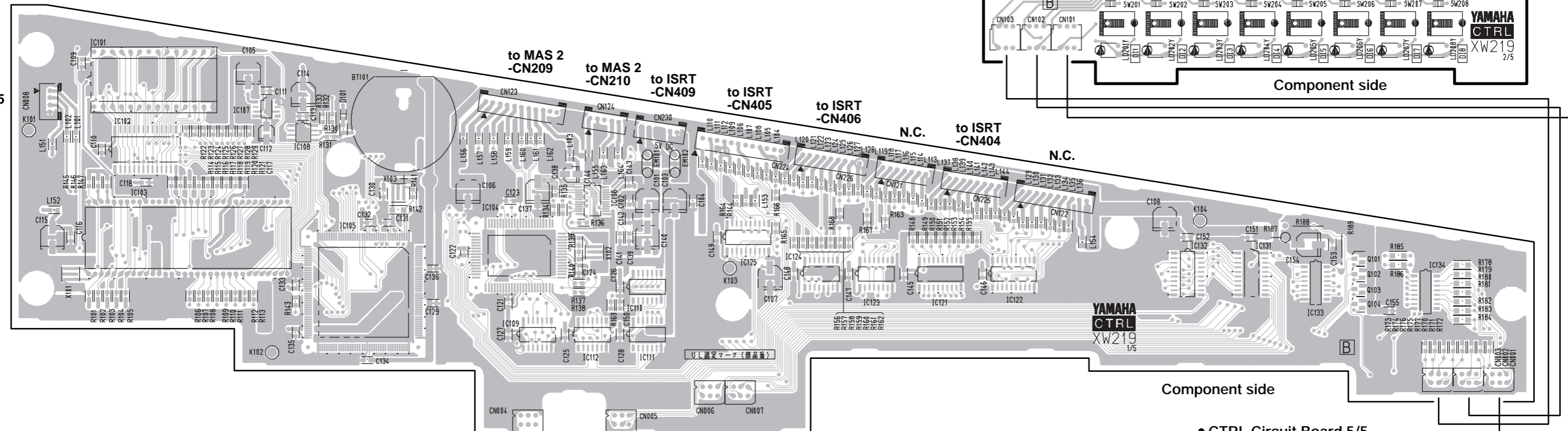

• CTRL Circuit Board 2/5

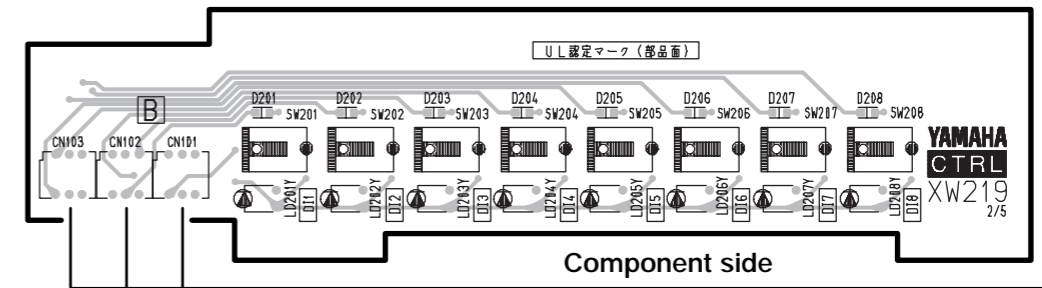

• CTRL Circuit Board 4/5

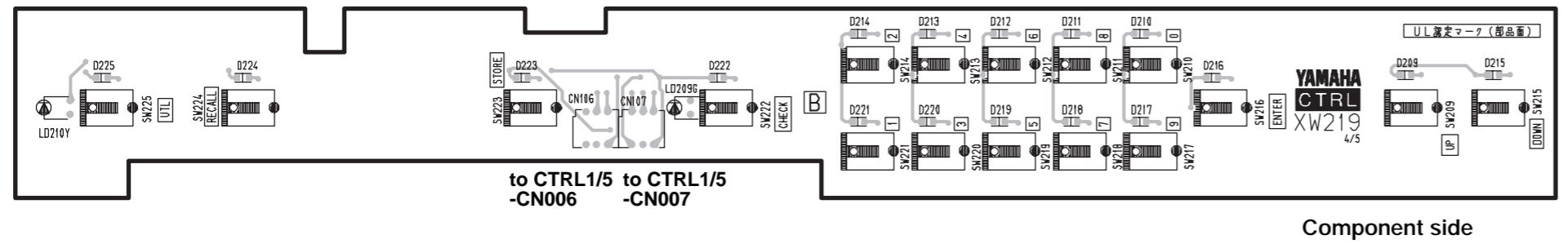

• CTRL Circuit Board 3/5

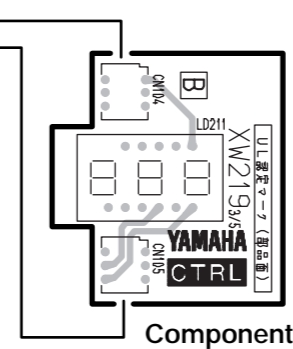

• CTRL Circuit Board 5/5

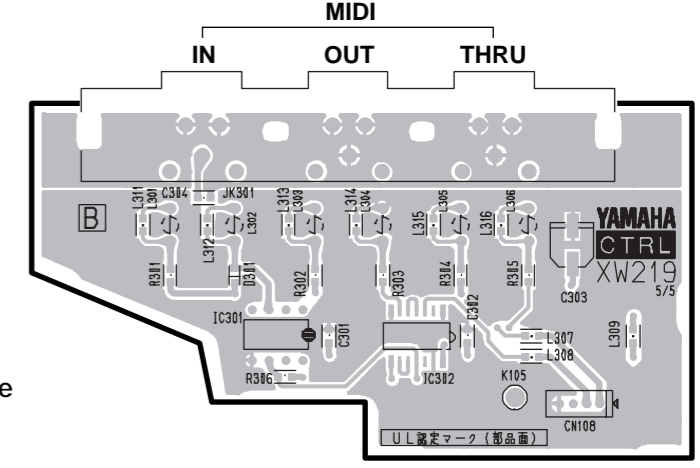

to CTRL1/5 -CN108

Component side

Battery VN103500
VN103600(Battery holder for VN103500)

- Notice for back-up battery removal
Push the battery as shows in figure, then the battery will pop up.
- Druk de batterij naar beneden zoals aangeven in de tekening, de batterij springt dan naar voren.

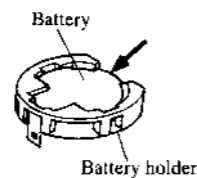

• CTRL Circuit Board 2/5

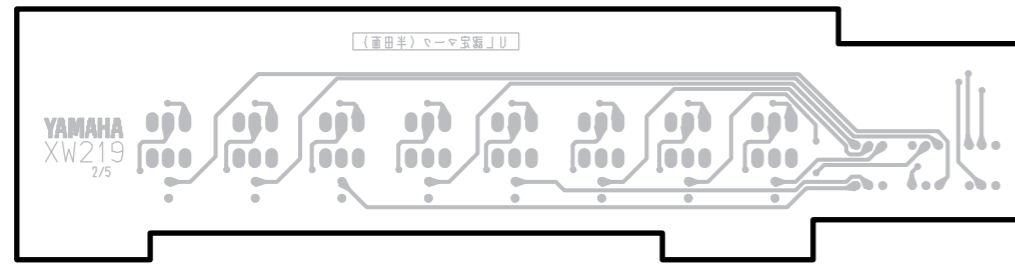

Pattern side

• CTRL Circuit Board 1/5

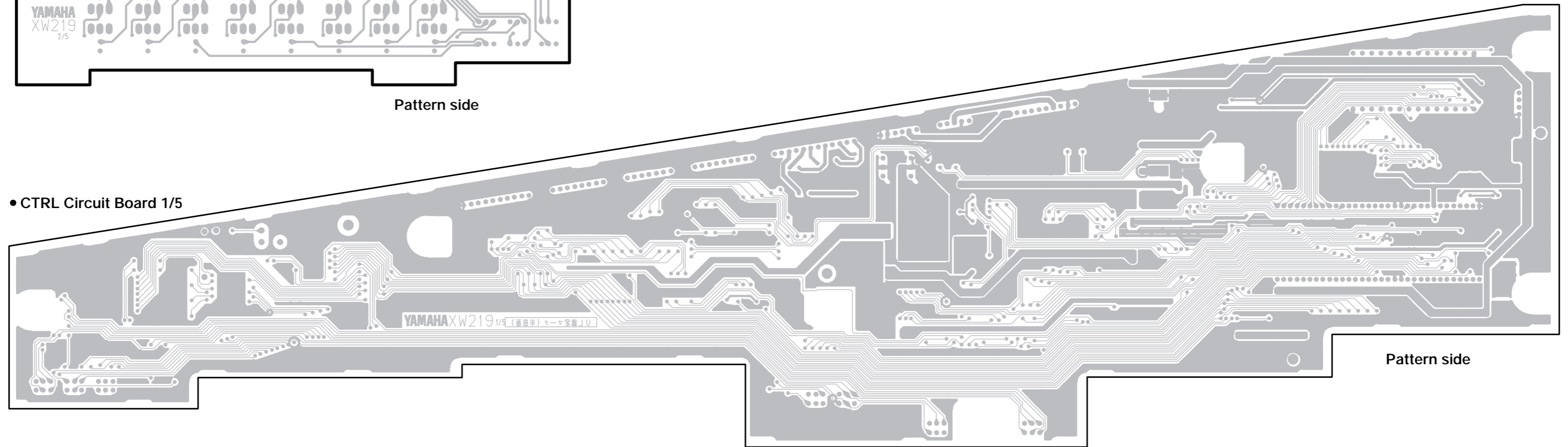

Pattern side

• CTRL Circuit Board 5/5

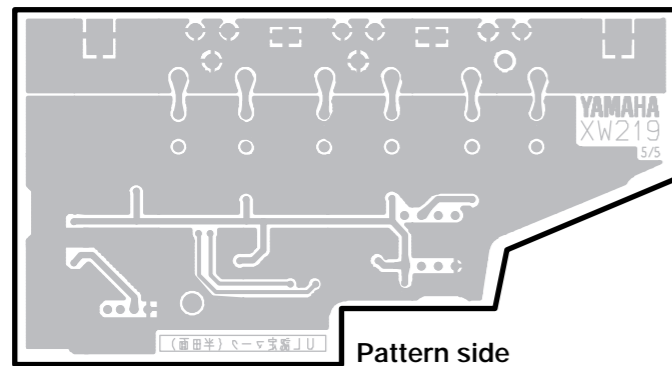

Pattern side

• CTRL Circuit Board 3/5

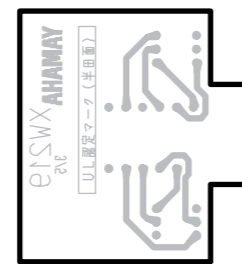

Pattern side

• CTRL Circuit Board 4/5

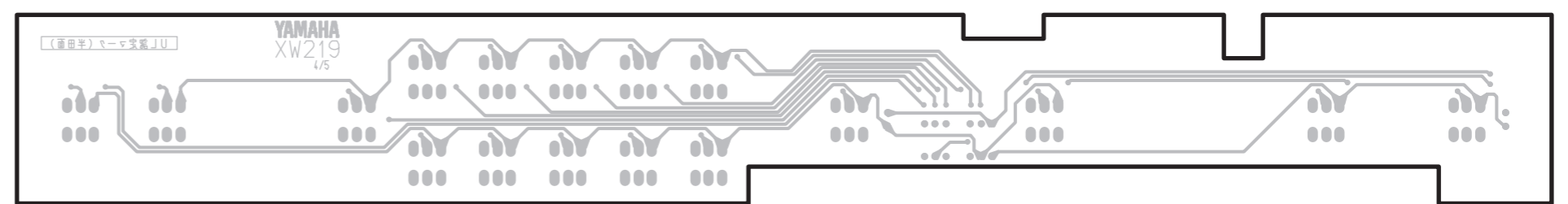

Pattern side

• IN1 Circuit Board

to INJK-CN602

to INJK-CN601

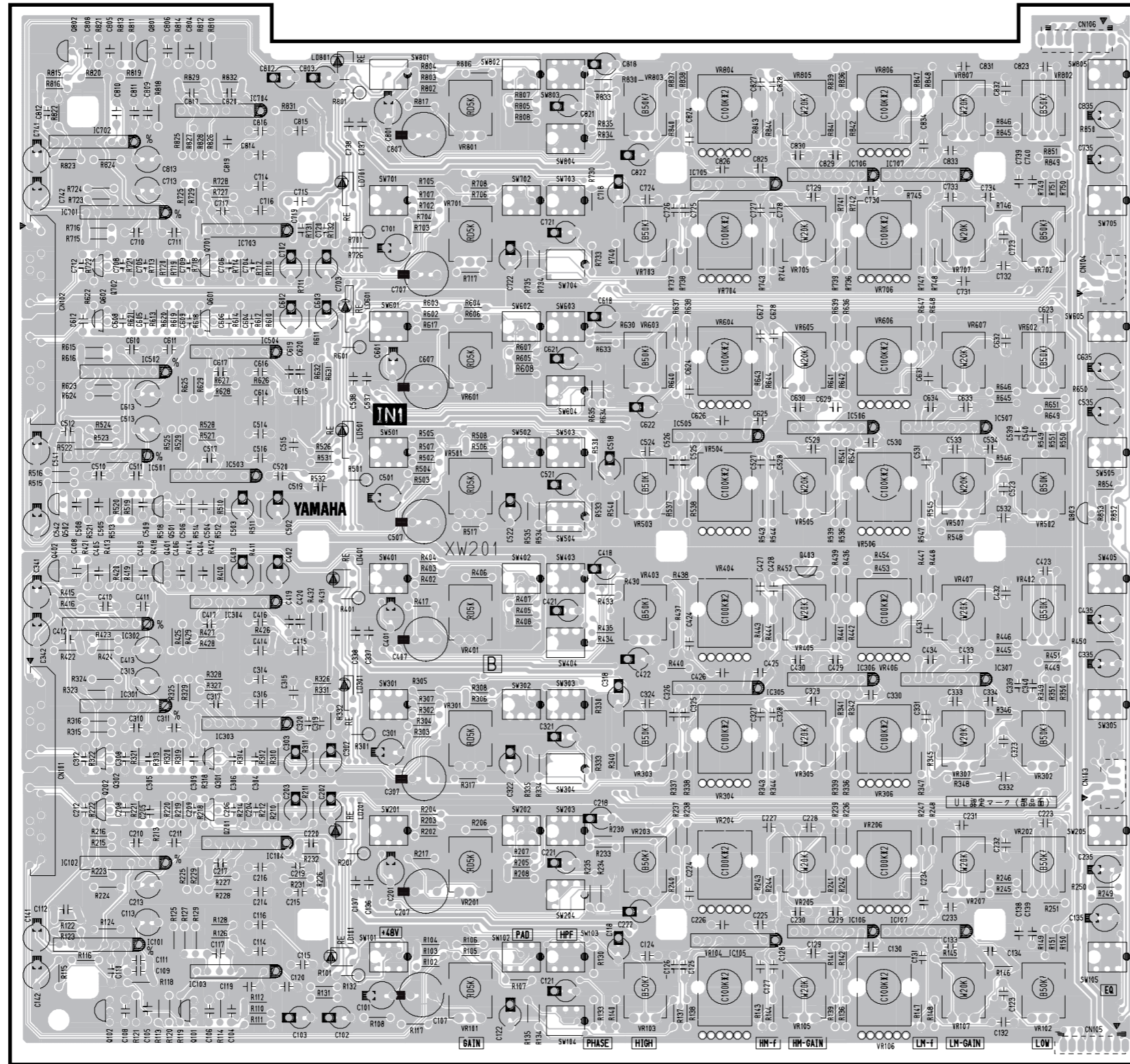

to IN1-CN105
ISRT-CN212
NC

to IN2
-CN202

to IN2
-CN201

to IN2-CN106
ISRT-CN314
NC

Component side

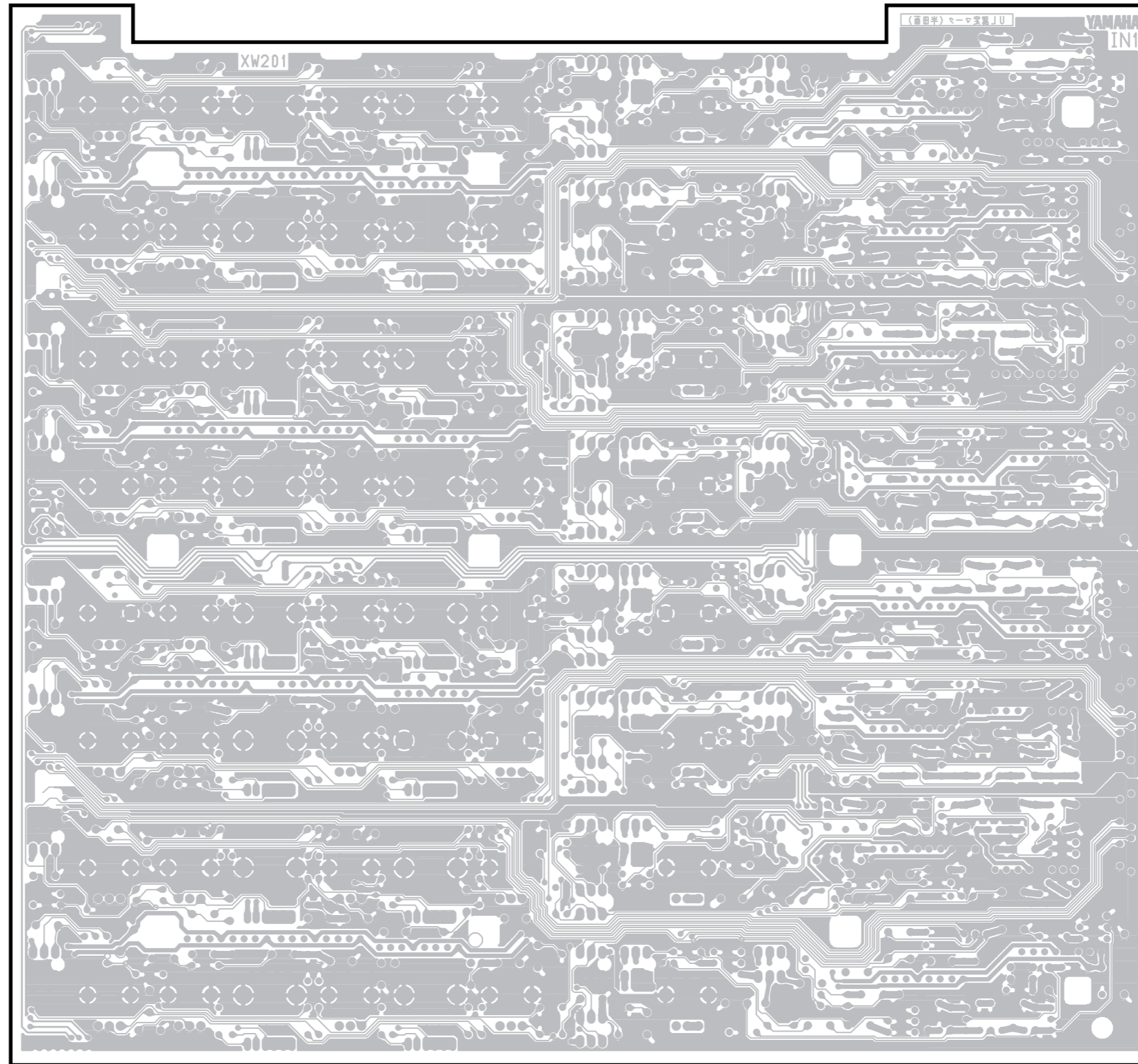

Pattern side

• IN2 Circuit Board



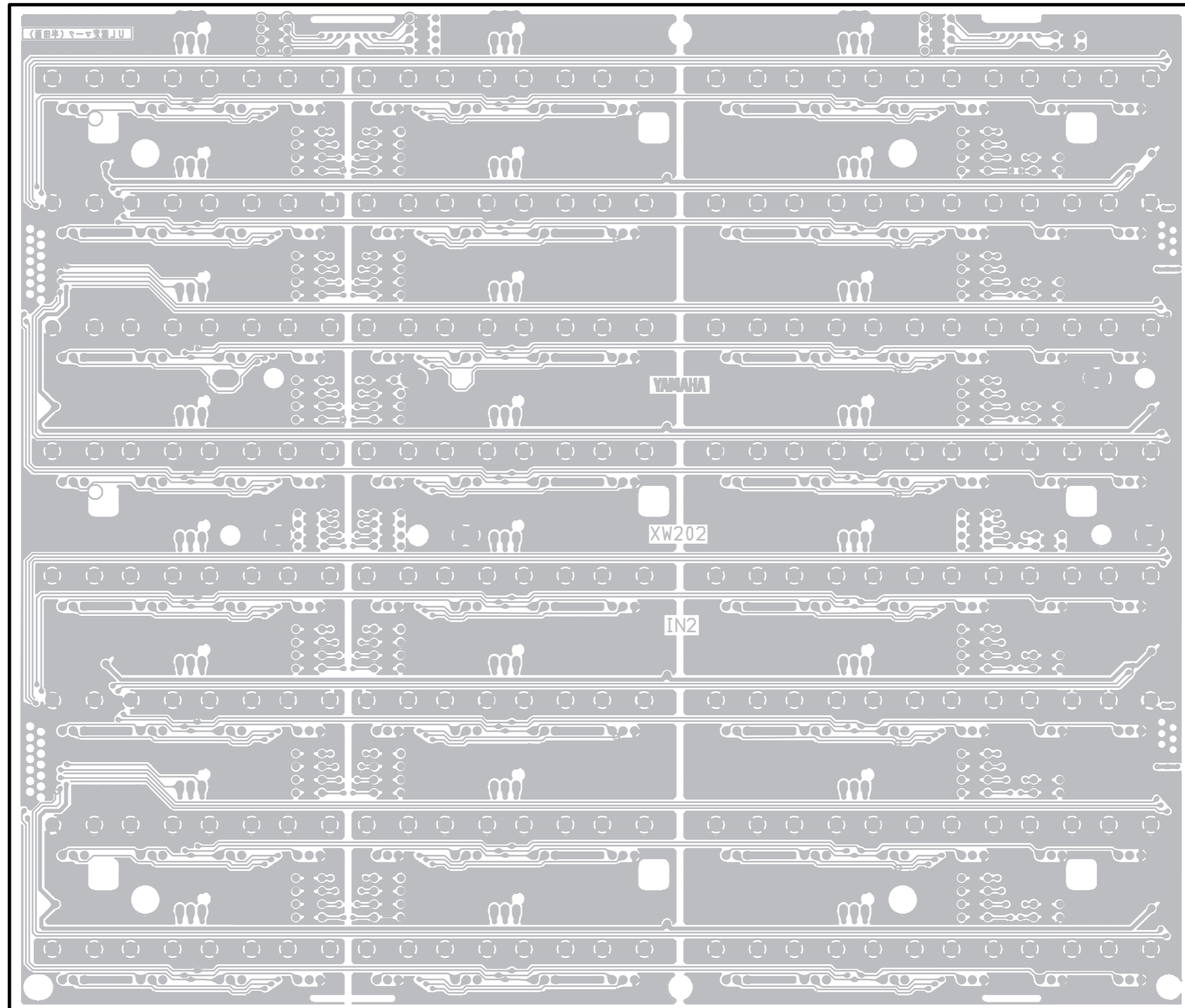

Pattern side

● IN3 Circuit Board

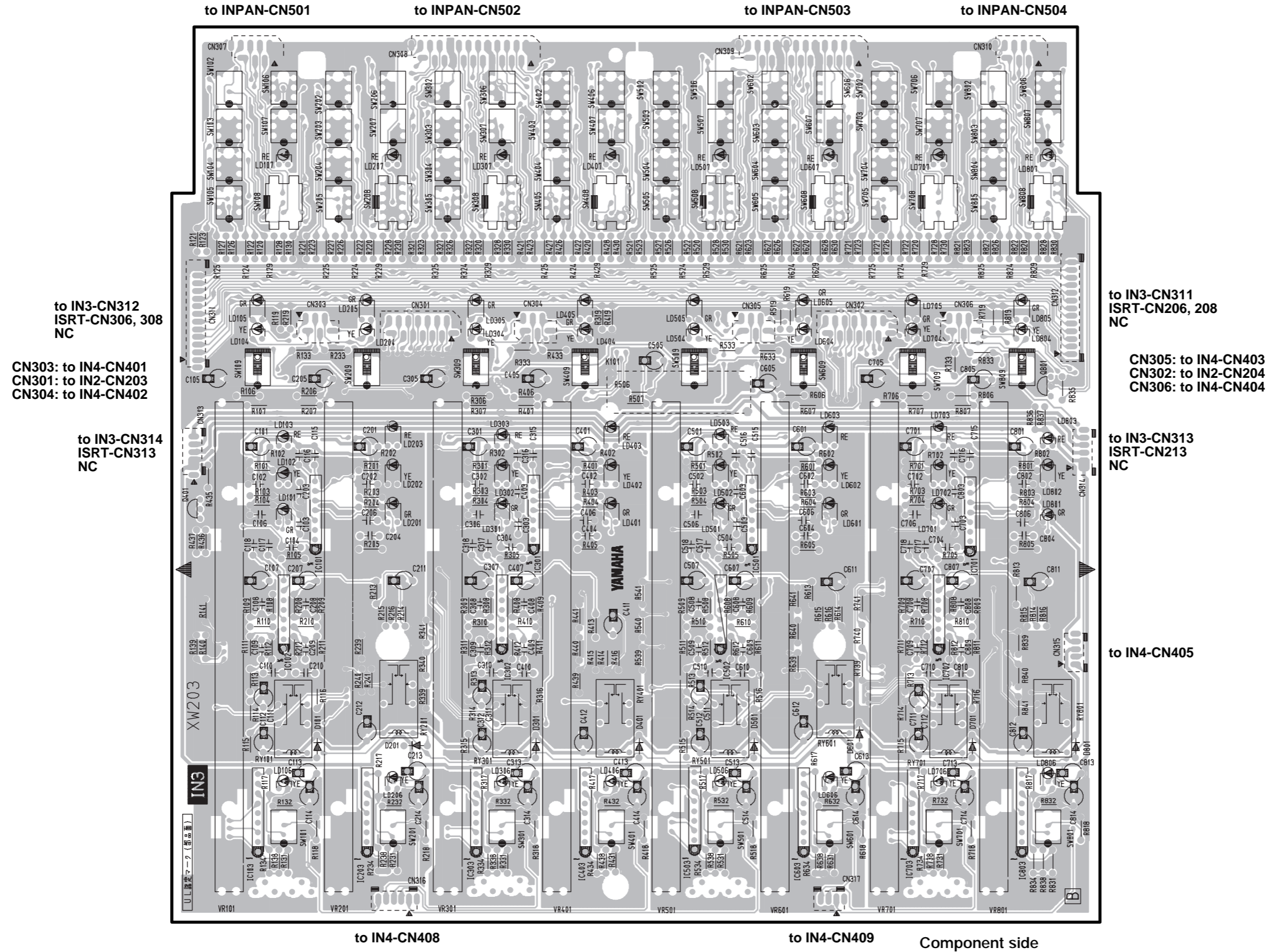

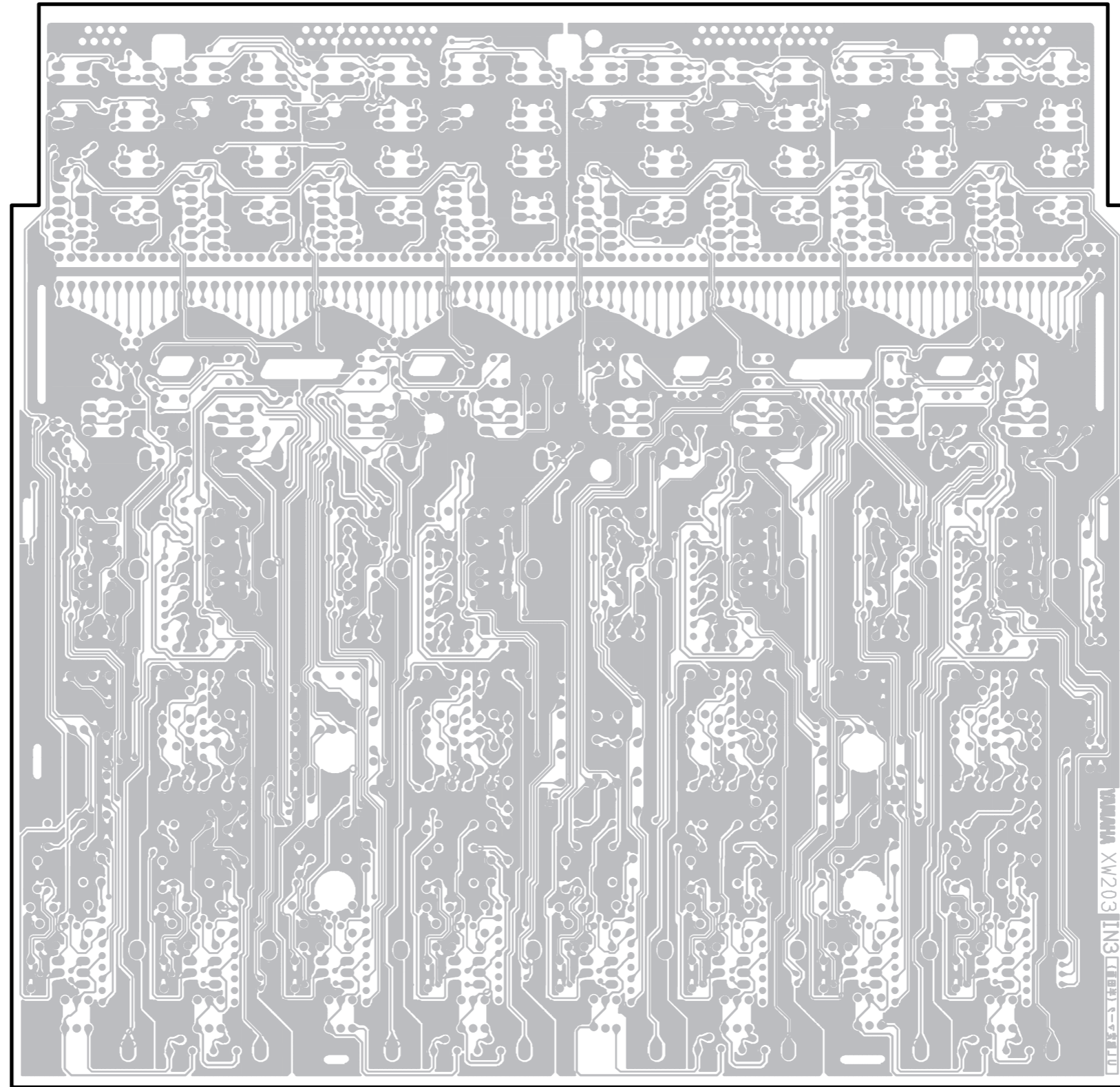

Pattern side

• IN4 Circuit Board

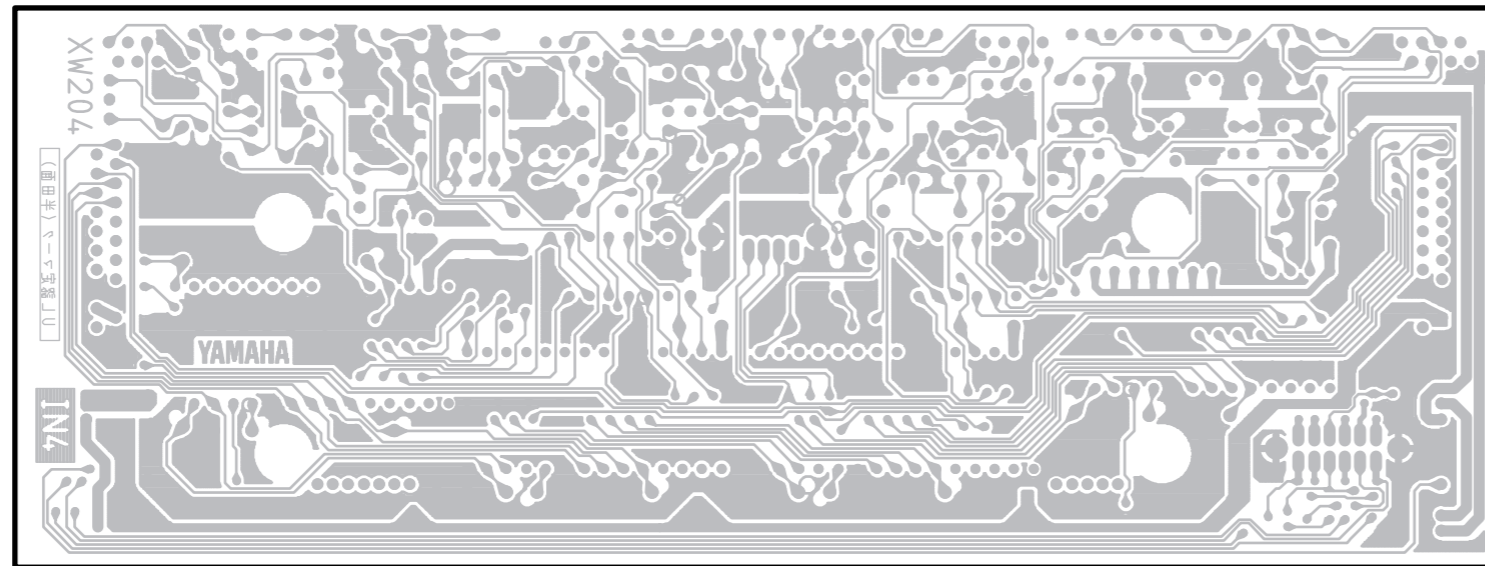
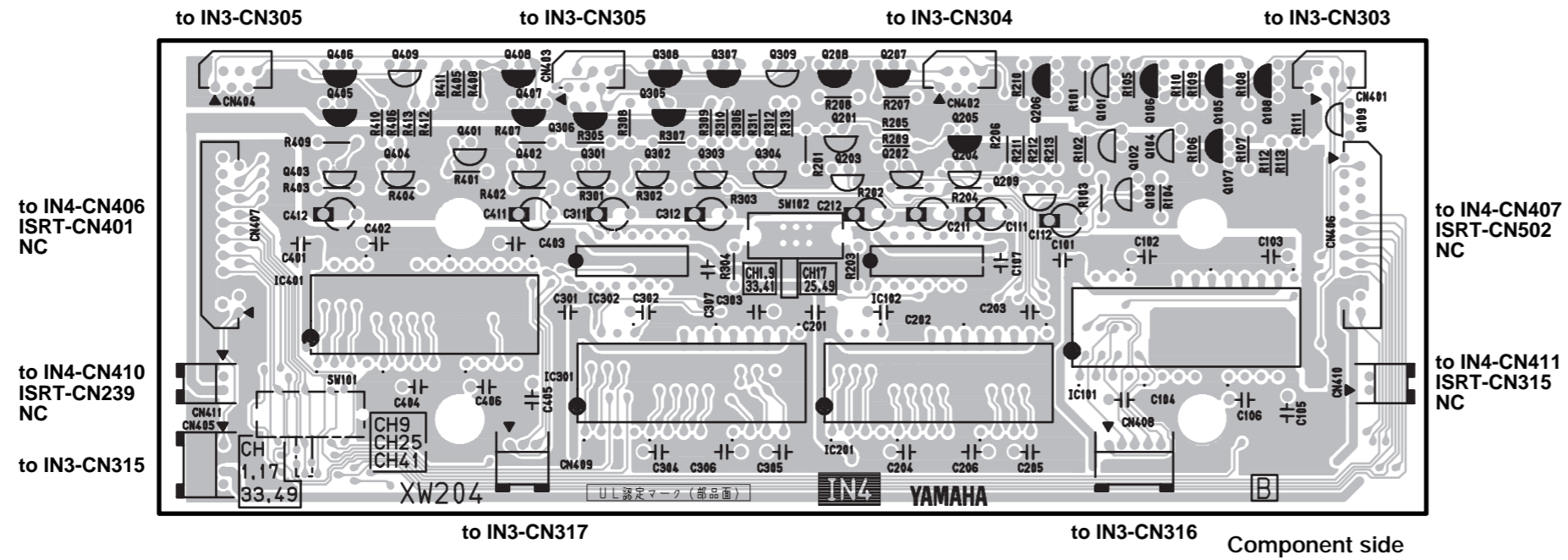

• INJK Circuit Board

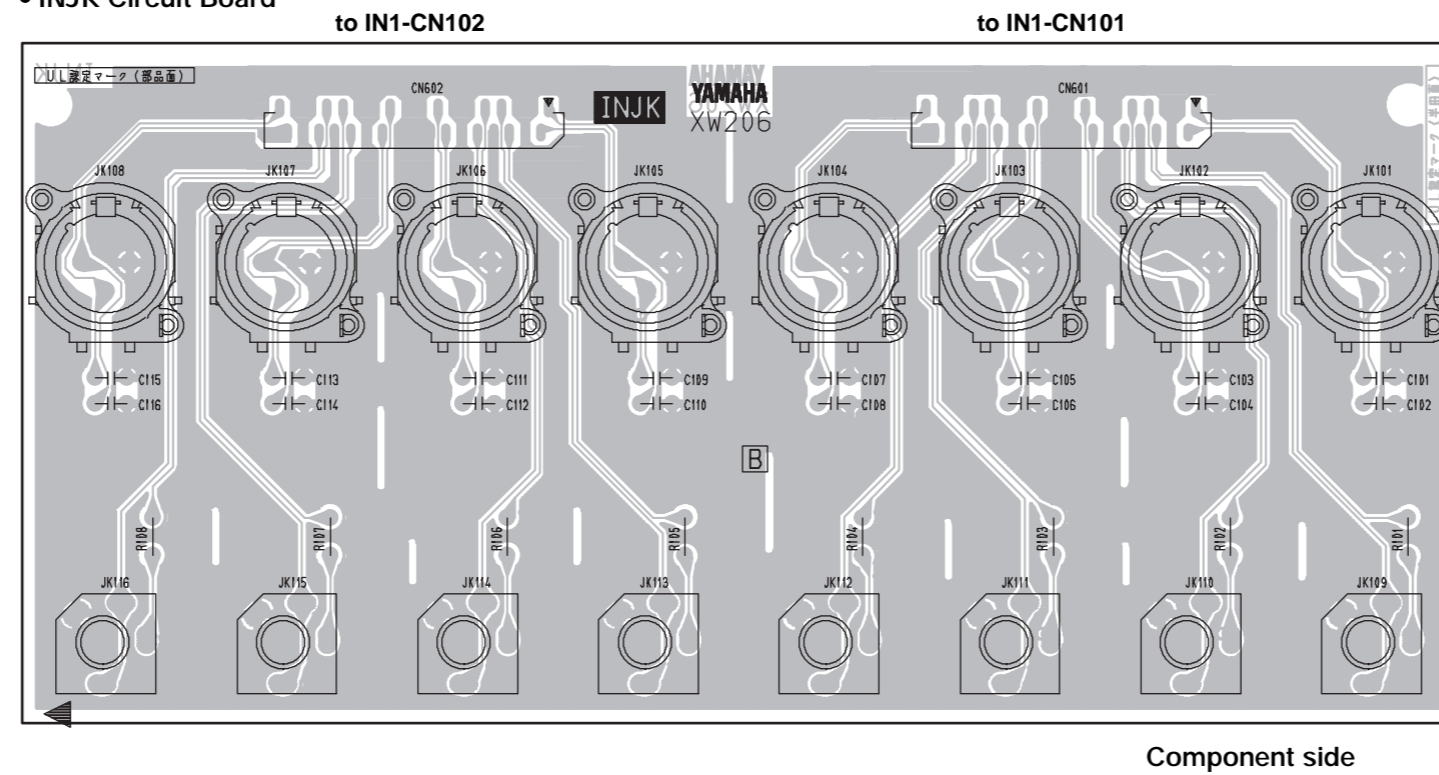

• INPAN Circuit Board

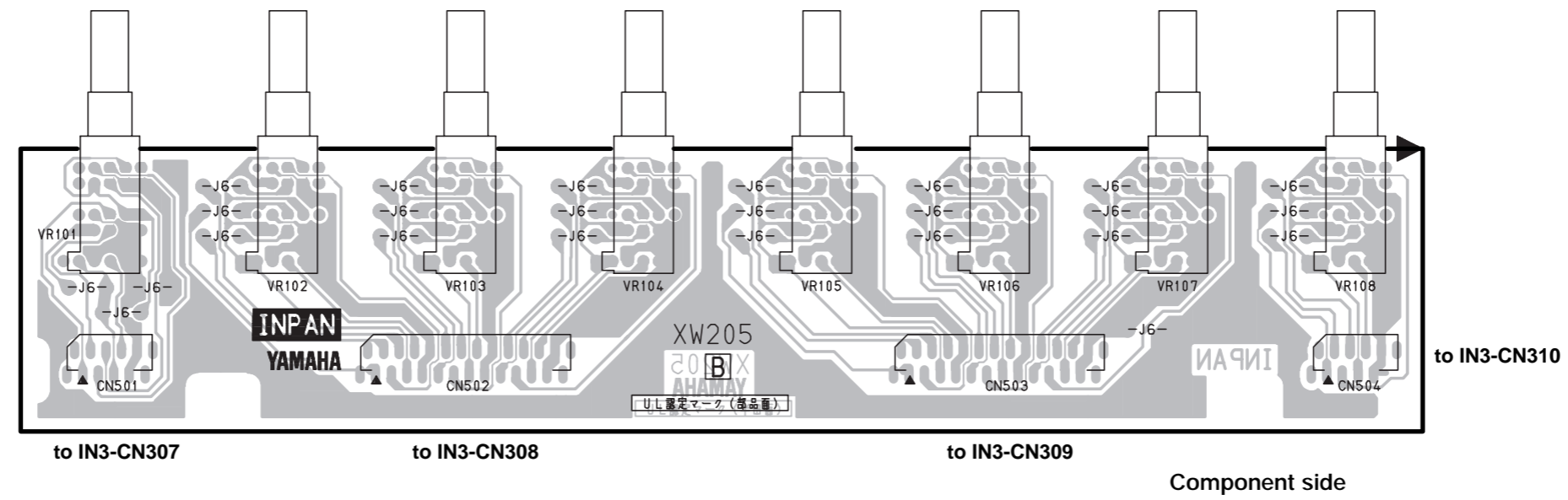

INJK: 3NA-V431270 ⚠
 INPAN: 3NA-V431340 ⚠

• ISRT 1/6 Circuit Board

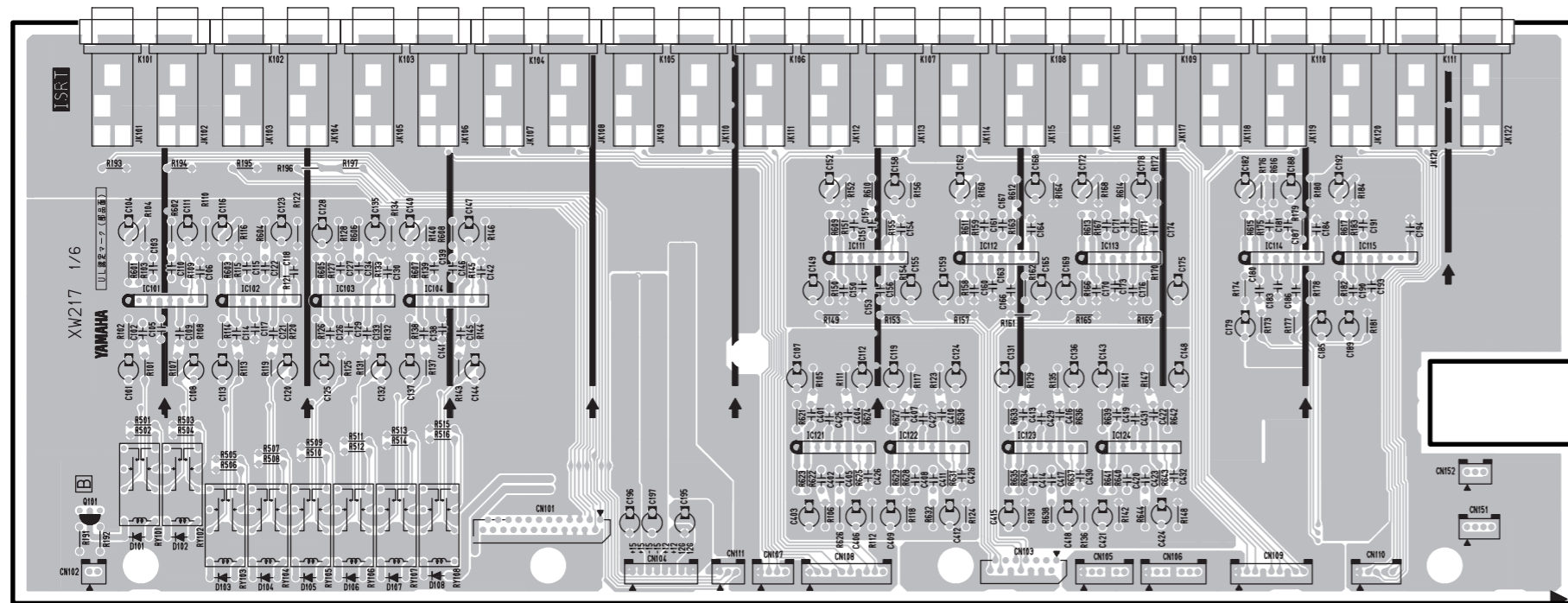

to MAS1 -CN104 to ISRT 2/6 -CN234 to ISRT 2/6 -CN236 to MAS1 -CN103 to MAS3 -CN306 to ISRT 2/6 -CN235 to MAS2 -CN202 to MAS2 -CN203 to MAS2 -CN208 to MAS3 -CN307

Component side

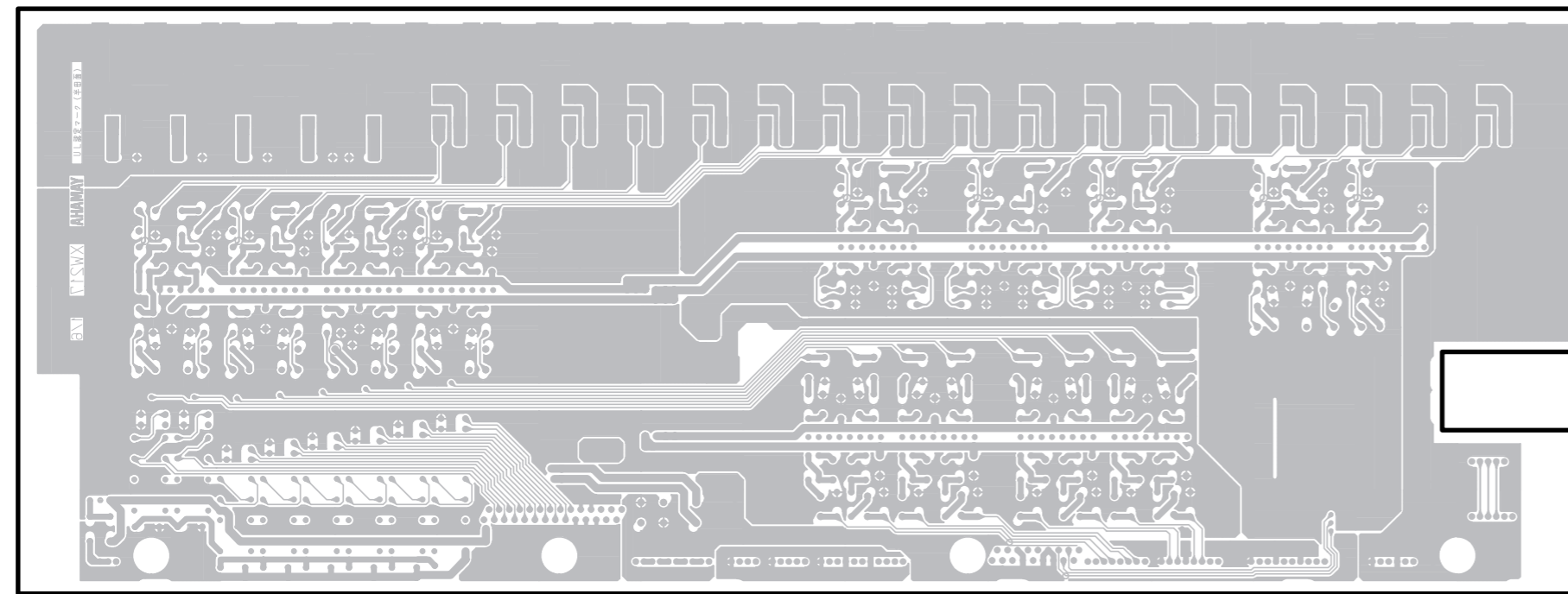

Pattern side

• ISRT 4/6 Circuit Board

to IN4-CN407

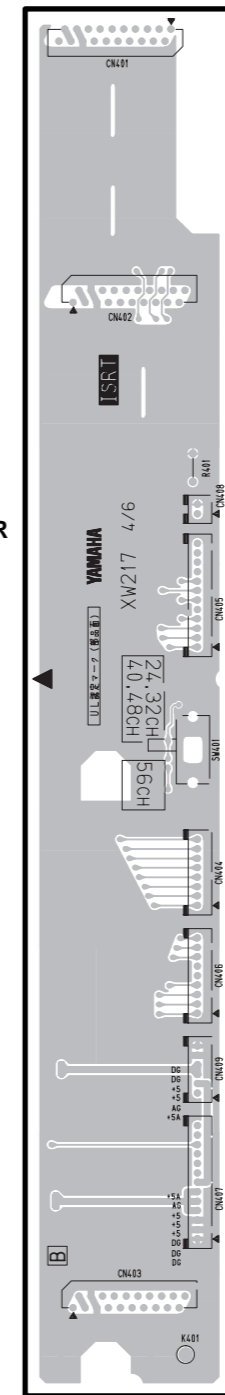

Component side

to ST4 -CN405

to MAS2 -CN211

to CTRL -CN224

to CTRL -CN225

to CTRL -CN226

to CTRL -CN230

to CTRL 2/6 -CN220

to ISRT 5/6 -CN501

Pattern side

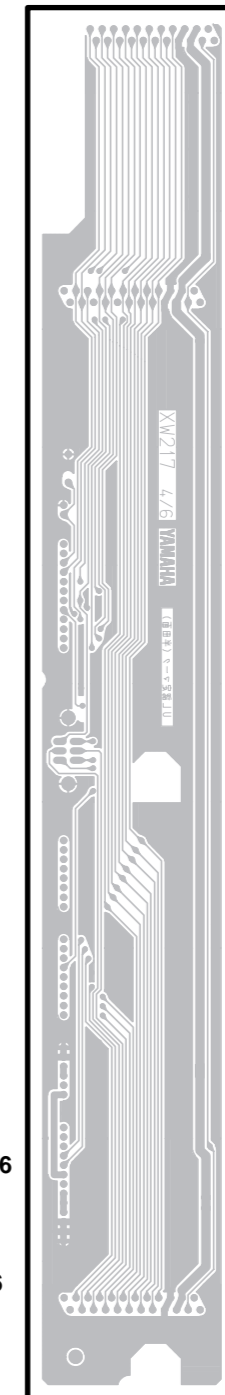

• ISRT 5/6 Circuit Board

to ISRT 4/6 -CN403

to IN4 -CN406

Component side



Pattern side



• ISRT 6/6 Circuit Board

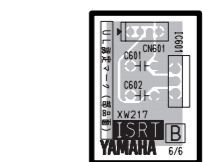

Component side



Pattern side

• ISRT 2/6 Circuit Board

- CN208: to IN3(L)-CN312
- CN207: to IN3(*L)-GND
- CN206: to IN3(L)-CN312
- CN210: to IN2(L)-GND
- CN203: to IN2(L)-CN208
- CN202: to IN2(L)-GND
- CN201: to IN2(L)-CN206

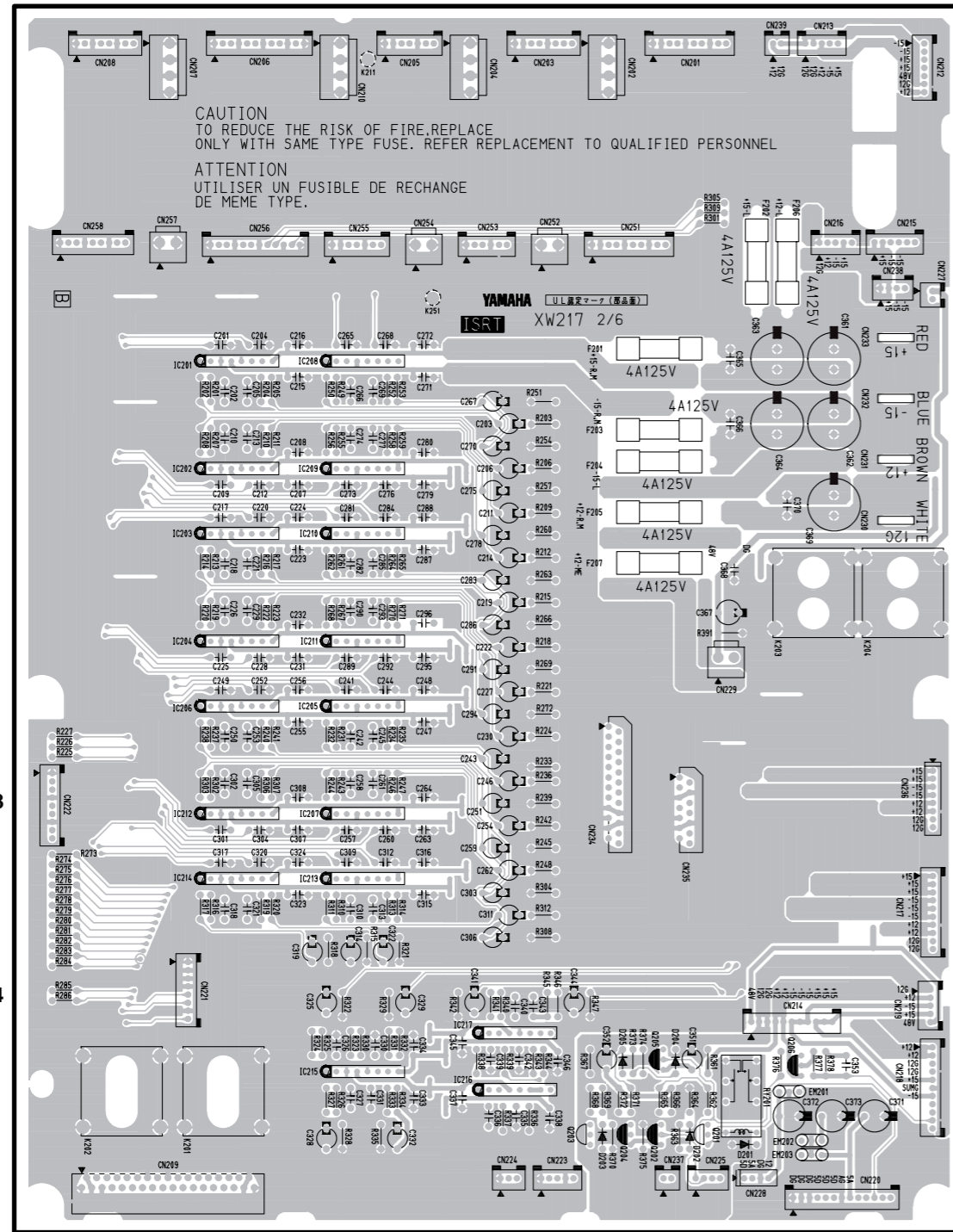

to IN1(L)-CN106

- CN216: to ST3-CN7
- CN215: to ST1-CN104
- CN238: to ST2-CN210
- CN227: to STJK2/2-CN102

- CN251: to ST2-CN206
- CN252: to ST2-CN207
- CN253: to ST2-CN208
- CN254: to ST2-CN209
- CN255: to ST2-CN208
- CN256: to ST3-CN308
- CN257: to ST3-CN310
- CN258: to ST3-CN308

- CN229: DCIN(1P)
- CN234: to ISRT 1/6-CN101
- CN235: to ISRT 1/6-CN103

to ISRT 1/6-CN104

to MAS1-CN105

to MAS1-CN109
CN214: to ISRT3/6-CN312

to METER

- CN220: to ISRT4/6-CN407
- CN228: to ISRT6/6-CN601
- CN225: to MAS2-CN212
- CN237: to MAS2-CN222

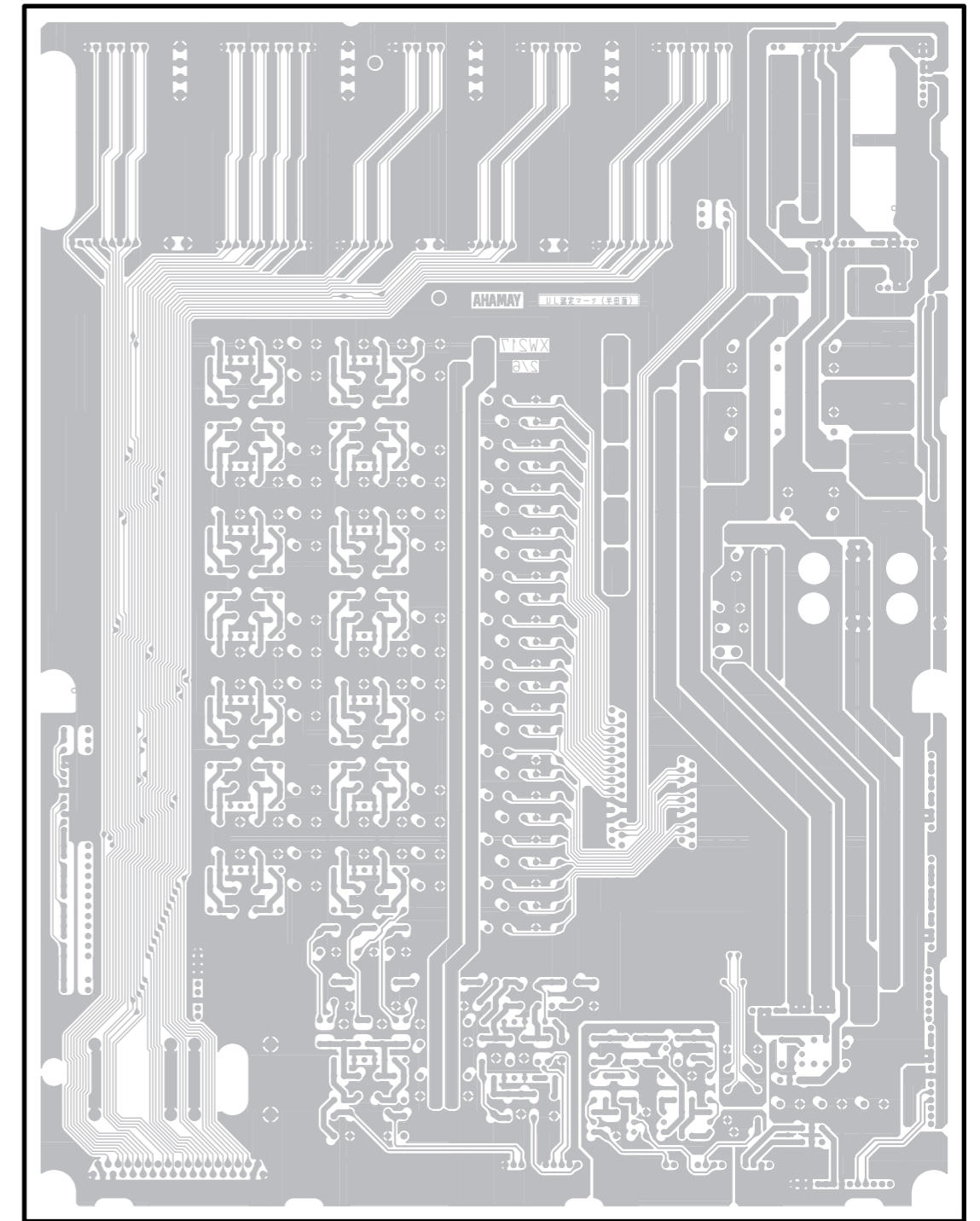

• ISRT 3/6 Circuit Board

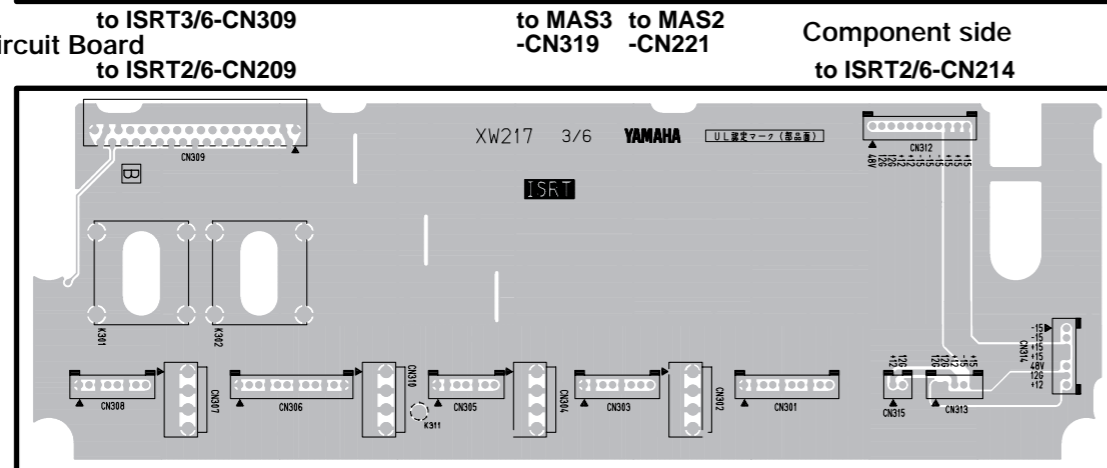

to IN1(R)-CN105

- CN313: to IN3(R)-CN313
- CN315: to IN4(R)-CN410
- CN301: to IN2(R)-CN205
- CN302: to IN2(R)-GND
- CN303: to IN2(R)-CN207
- CN304: to IN2(R)-GND
- CN305: to IN2(R)-CN207
- CN310: to IN2(R)-GND
- CN306: to IN3(R)-CN311
- CN307: to IN3(R)-GND
- CN308: to IN3(R)-CN311

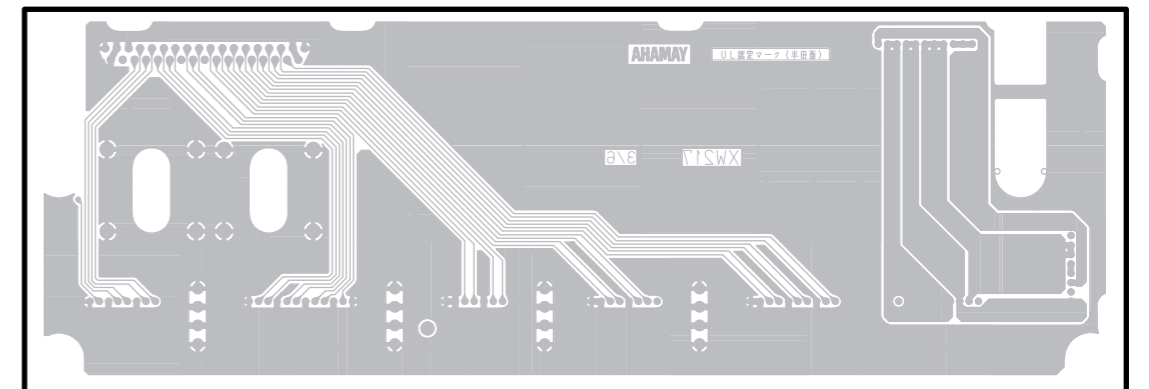

● MAS1 1/2 Circuit Board

to MASOUT-CN321

to MASOUT-CN321

to ISRT-CN111 to ISRT-CN102 to ISRT-CN217

● MAS1 2/2 Circuit Board

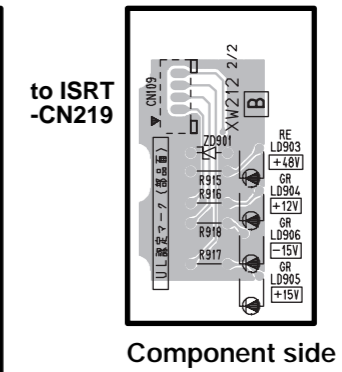
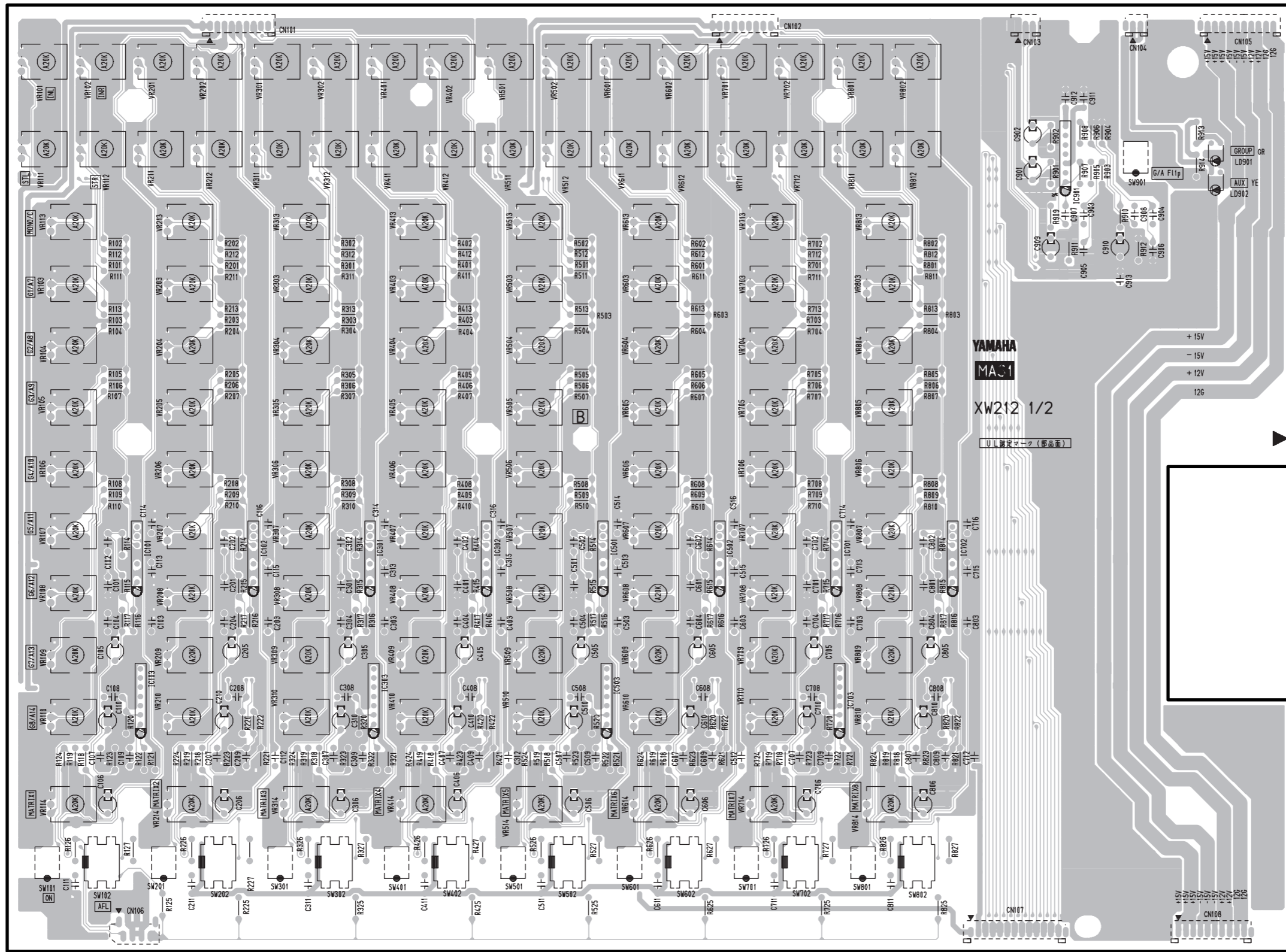

Component side

to MAS2-CN201

to MAS3-CN311

to MAS2-CN215

Component side

● MAS1 1/2 Circuit Board

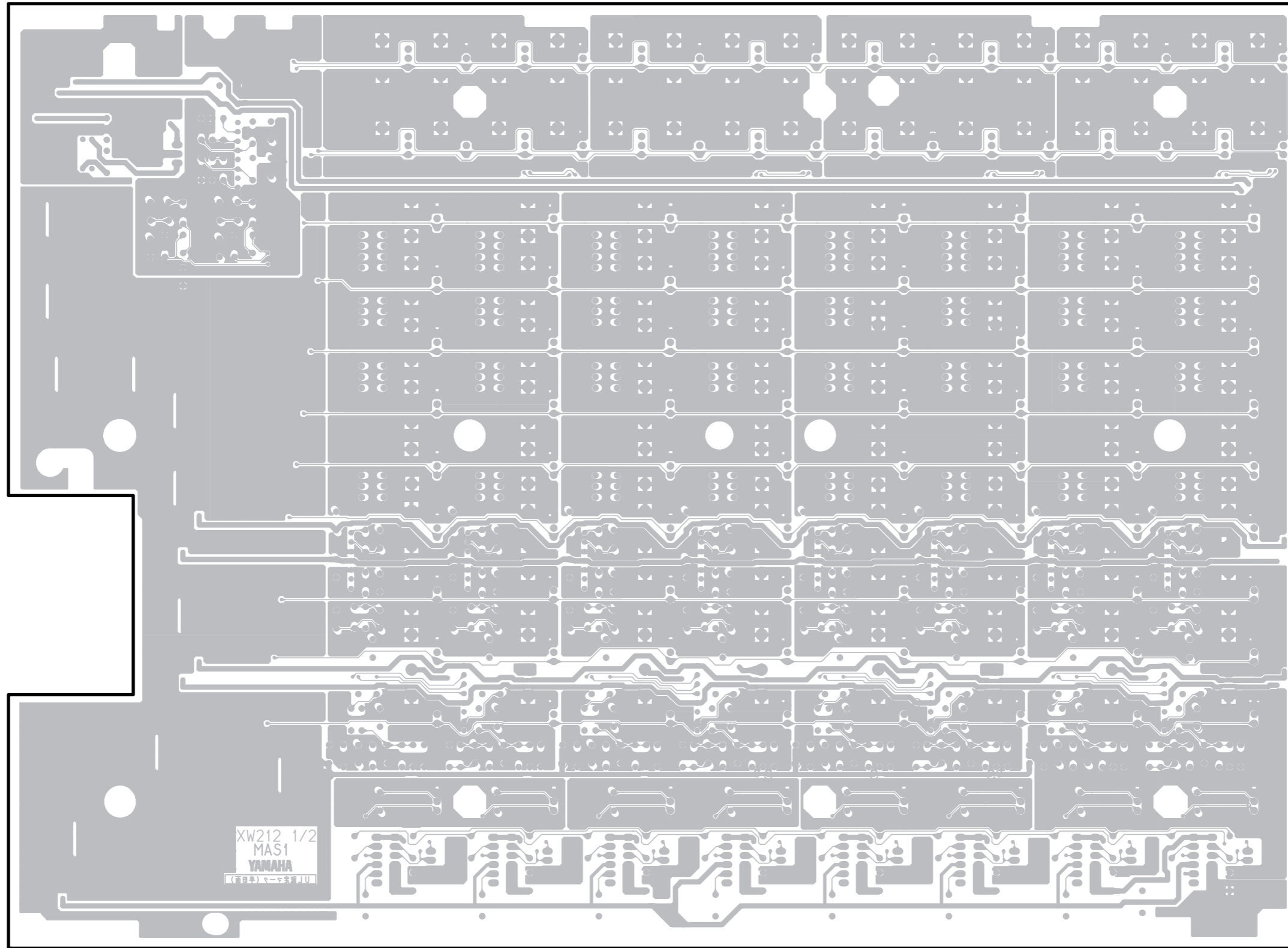

Pattern side

● MAS1 2/2 Circuit Board

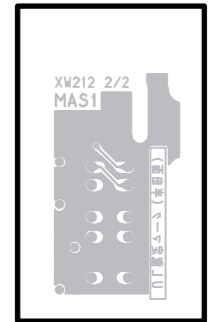

Pattern side

● MAS2 1/2, 2/2 Circuit Board

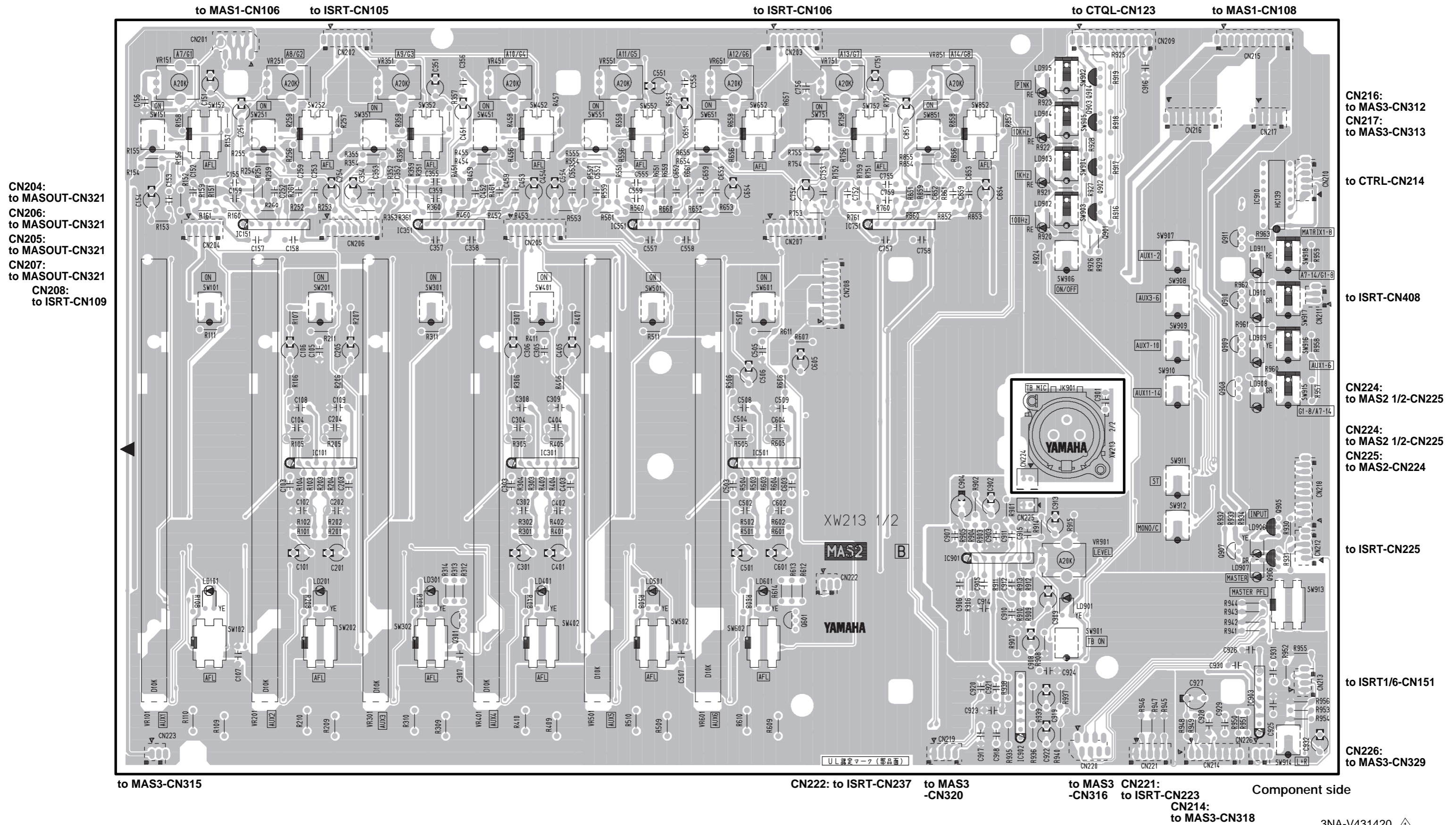

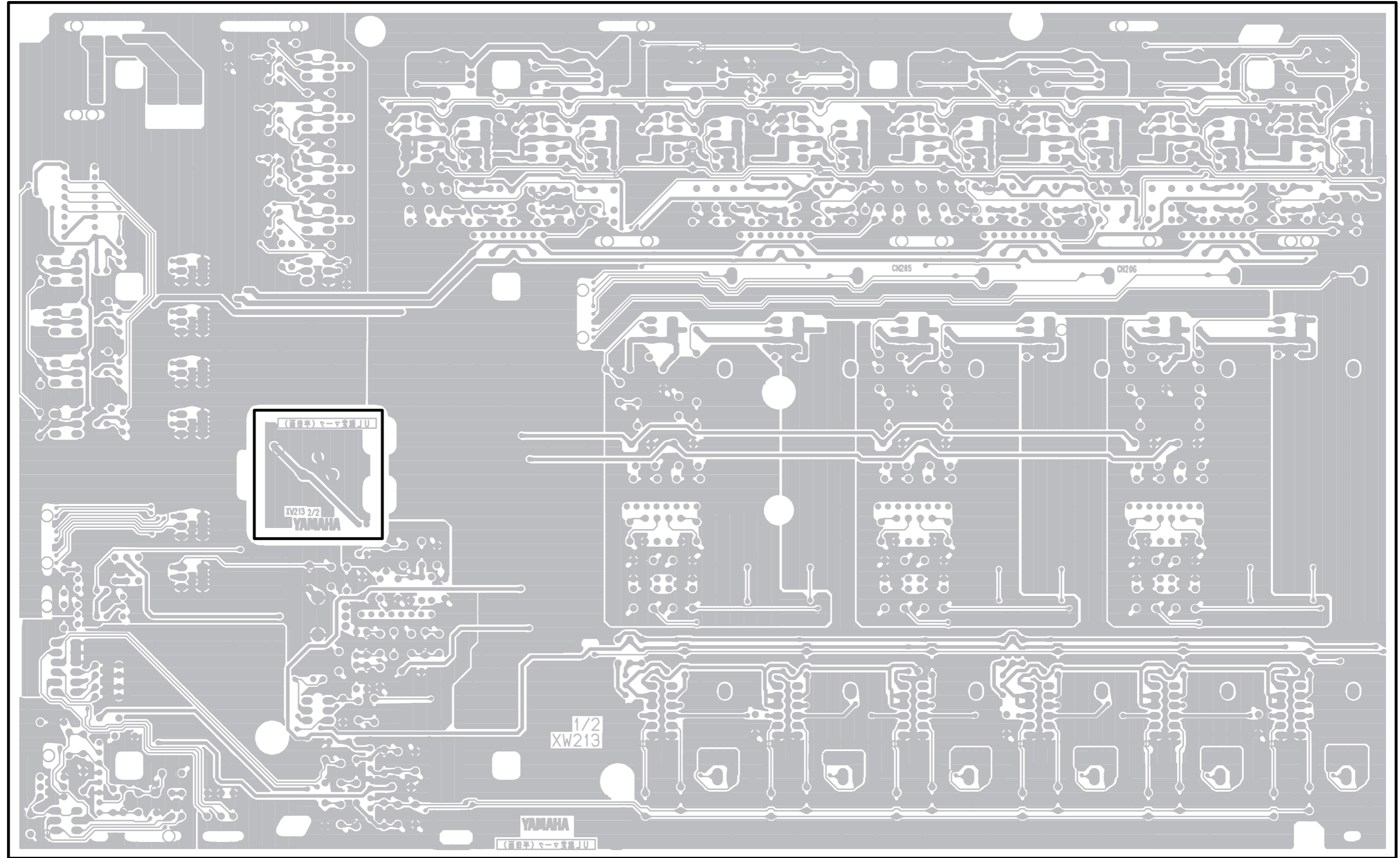

Pattern side

• MAS3 1/2 Circuit Board

to ISRT-CN107

to MASPAN-CN101

to MASPAN-CN102

to MASPAN-CN103

to MASPAN-CN104

to MAS2-CN219

to MAS2-CN226

• MAS3 2/2 Circuit Board

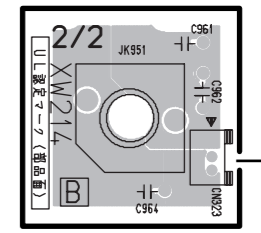
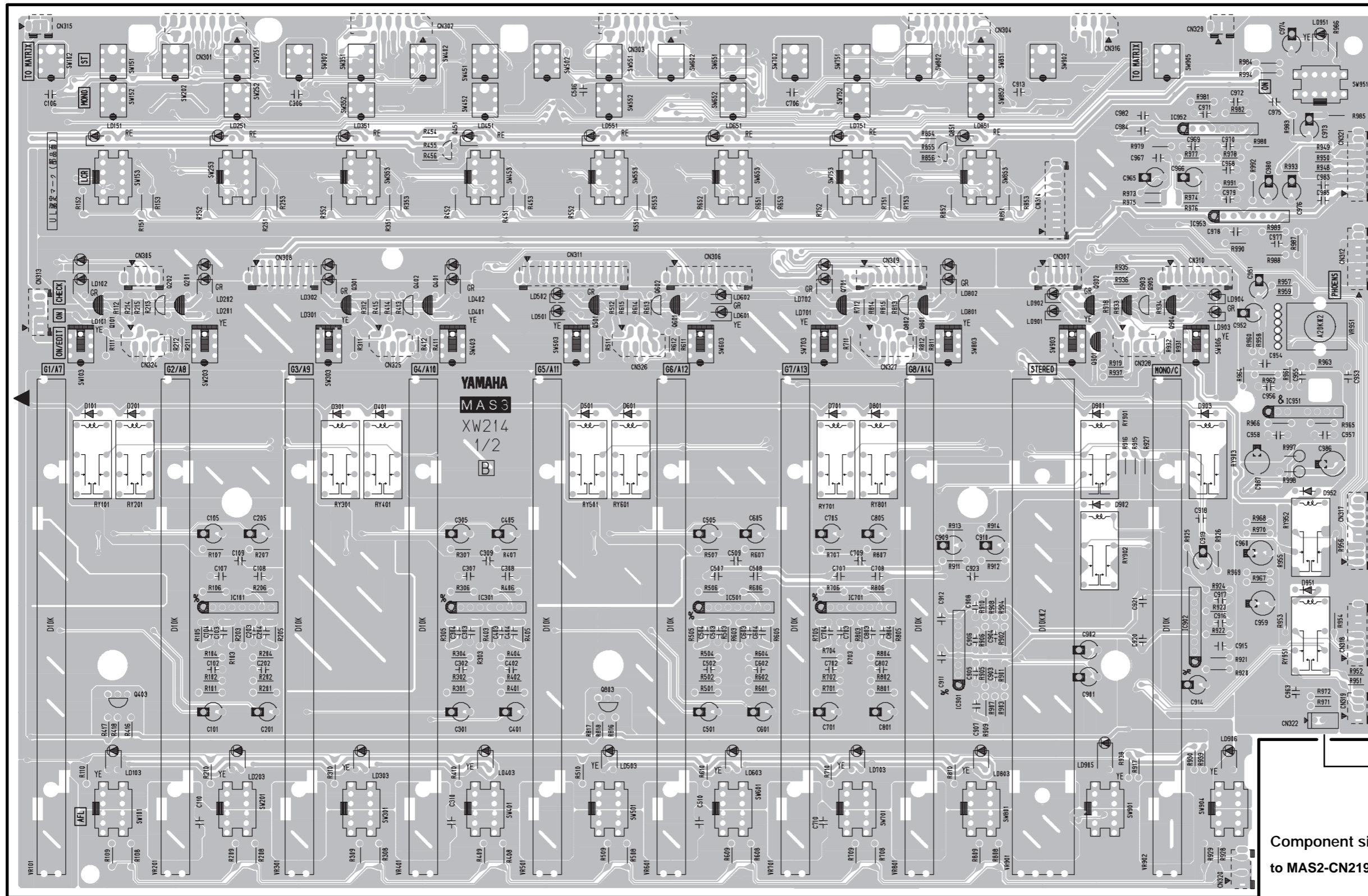

Component side to MASOUT-CN321

to MAS2-CN216

to MASPAN-CN105

to MAS2-CN214

to ISRT-CN224

Component side to MAS2-CN219

CN305:
CN324:
to MAS4-CN401

CN308:
to MASOUT-CN321

CN325:
to MAS4-CN402

CN311:
to MAS1-CN107

CN326:
to MAS4-CN403

CN306:
to ISRT-CN108

CN309:
to MASOUT-CN321
CN327:
to MAS4-CN404

CN314:
to ISRT-CN221
CN307:
to ISRT-CN110

CN328:
to MAS4-CN405

CN310:
to MASOUT-CN321

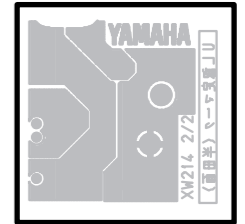
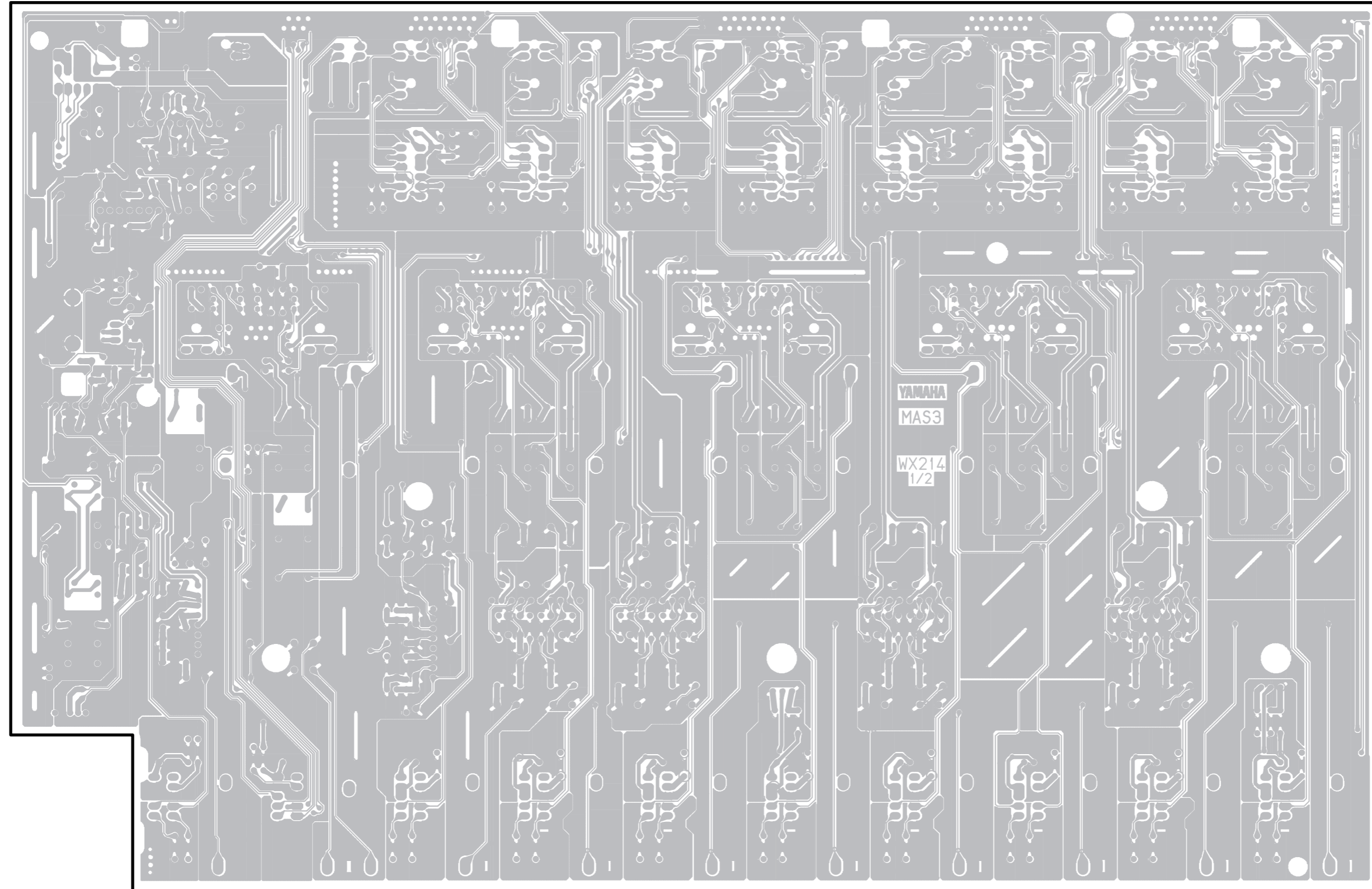

Pattern side

Pattern side

• MAS4 Circuit Board

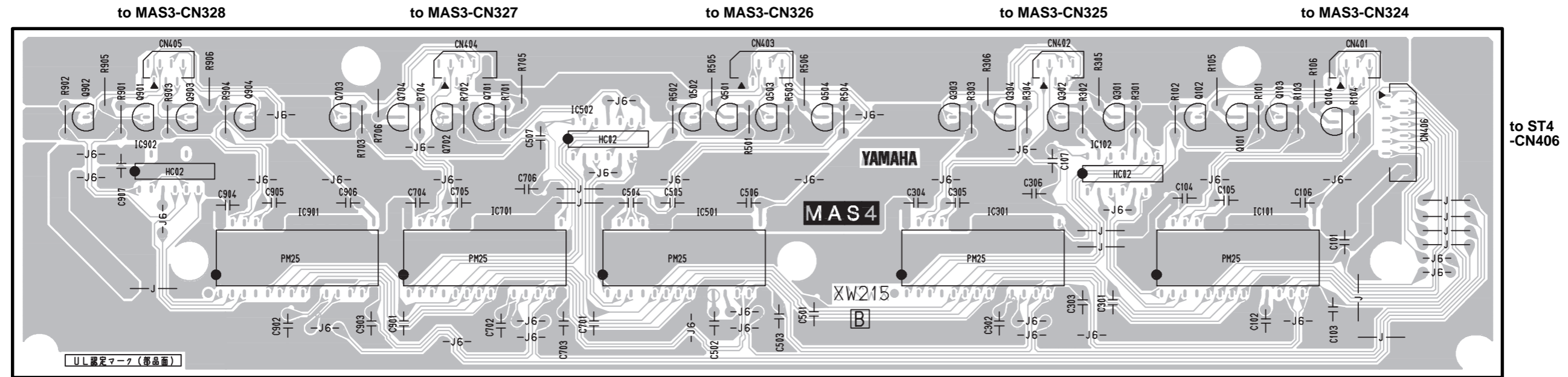

Component side

• MASPAN 1/2 Circuit Board

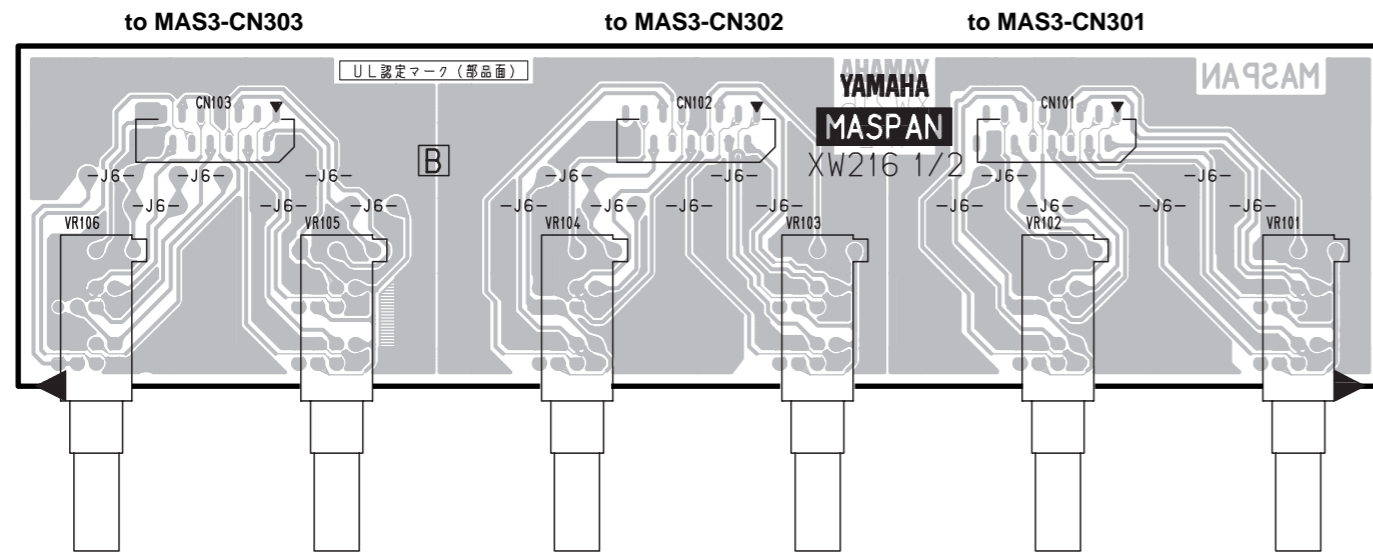

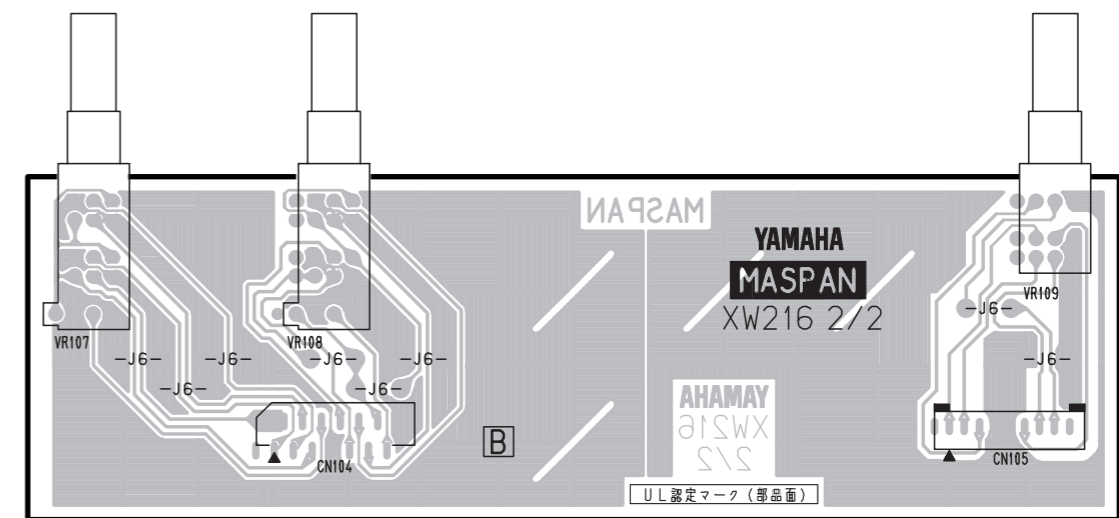

Component side

• MASPAN 2/2 Circuit Board



Component side

MAS4: 3NA-V431450 
 MASPAN: 3NA-V431430 

● ST1 Circuit Board

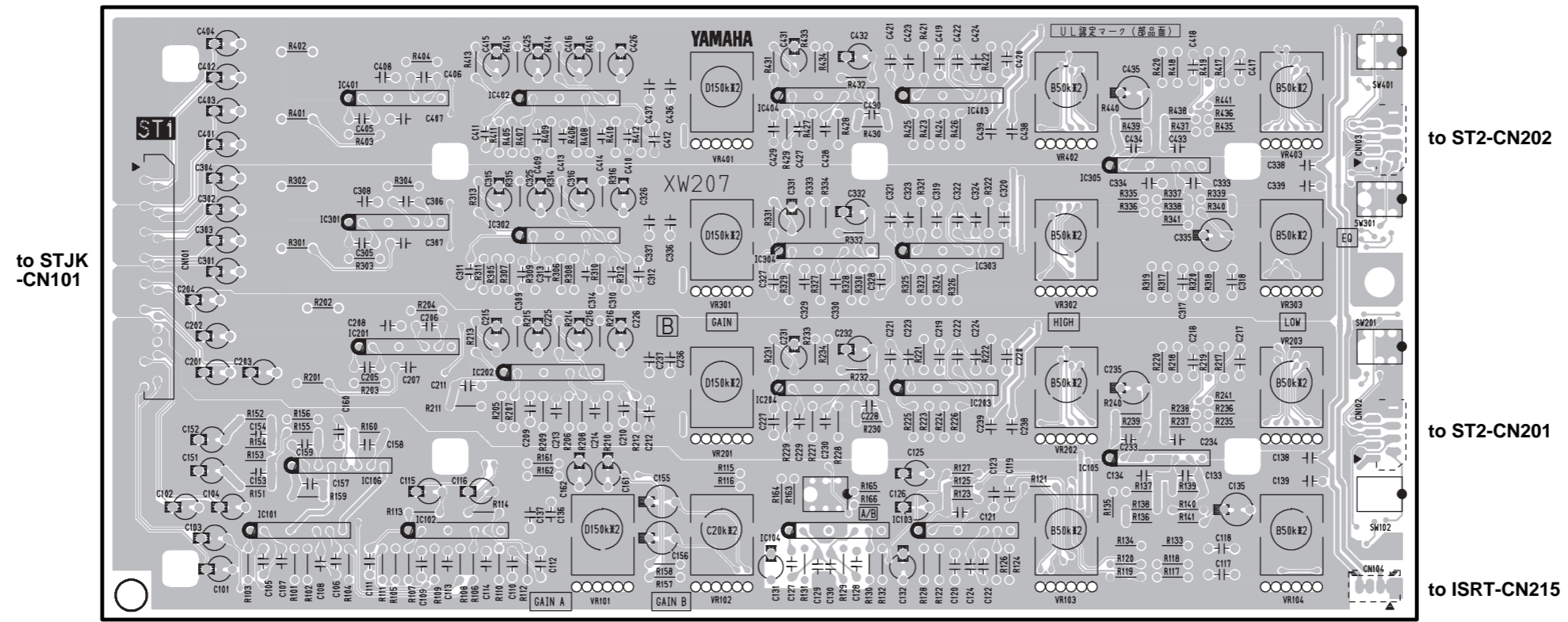

Component side

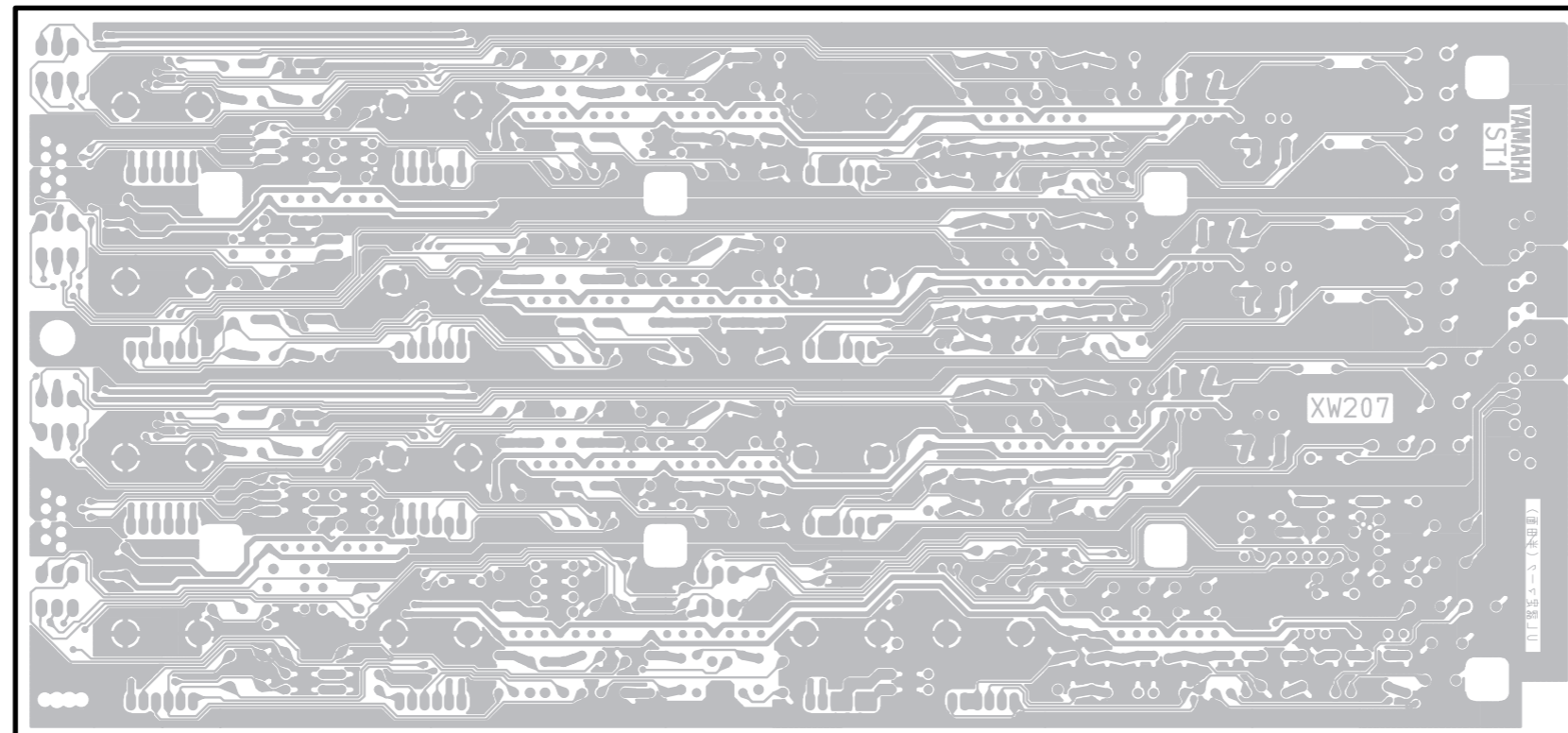

Pattern side

• ST2 Circuit Board

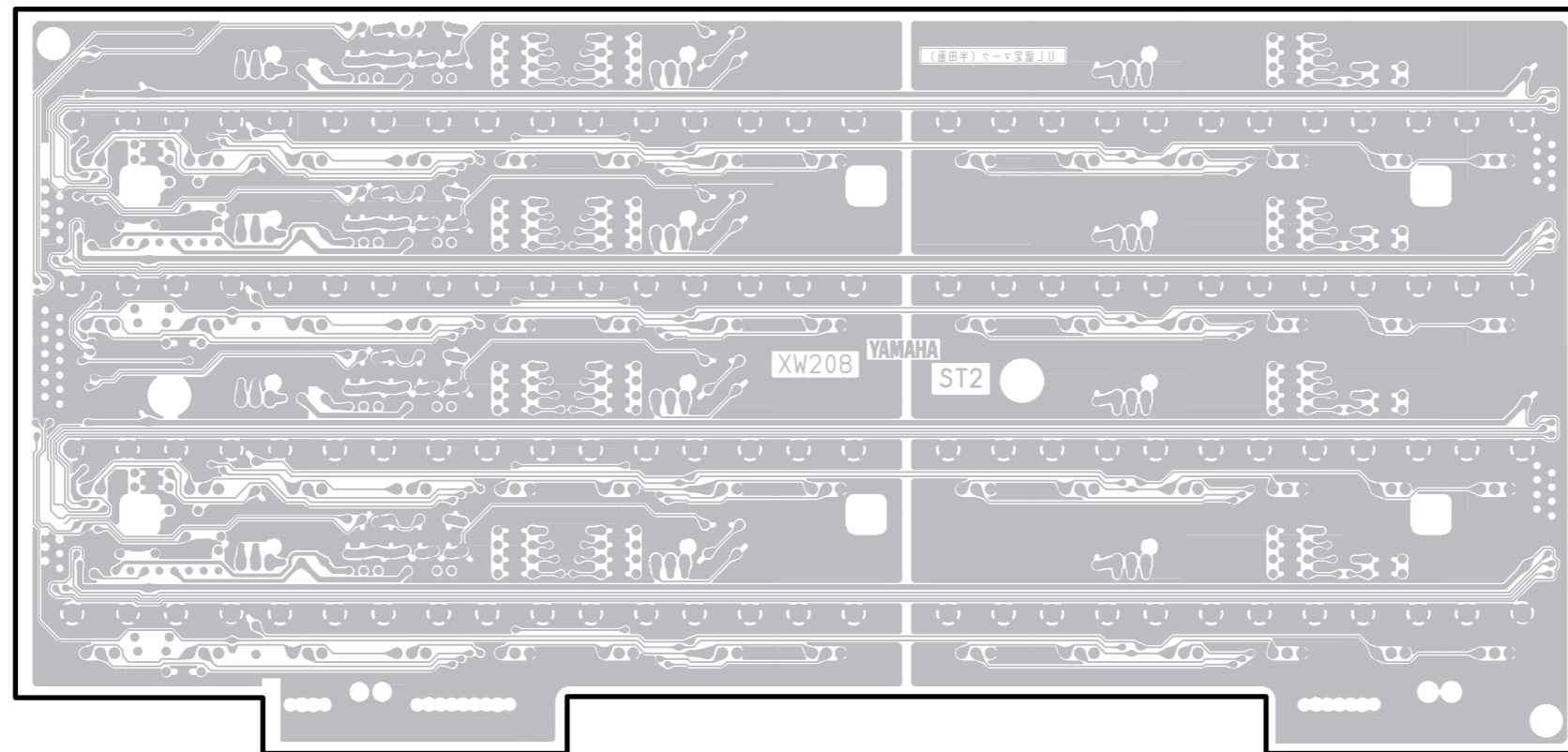
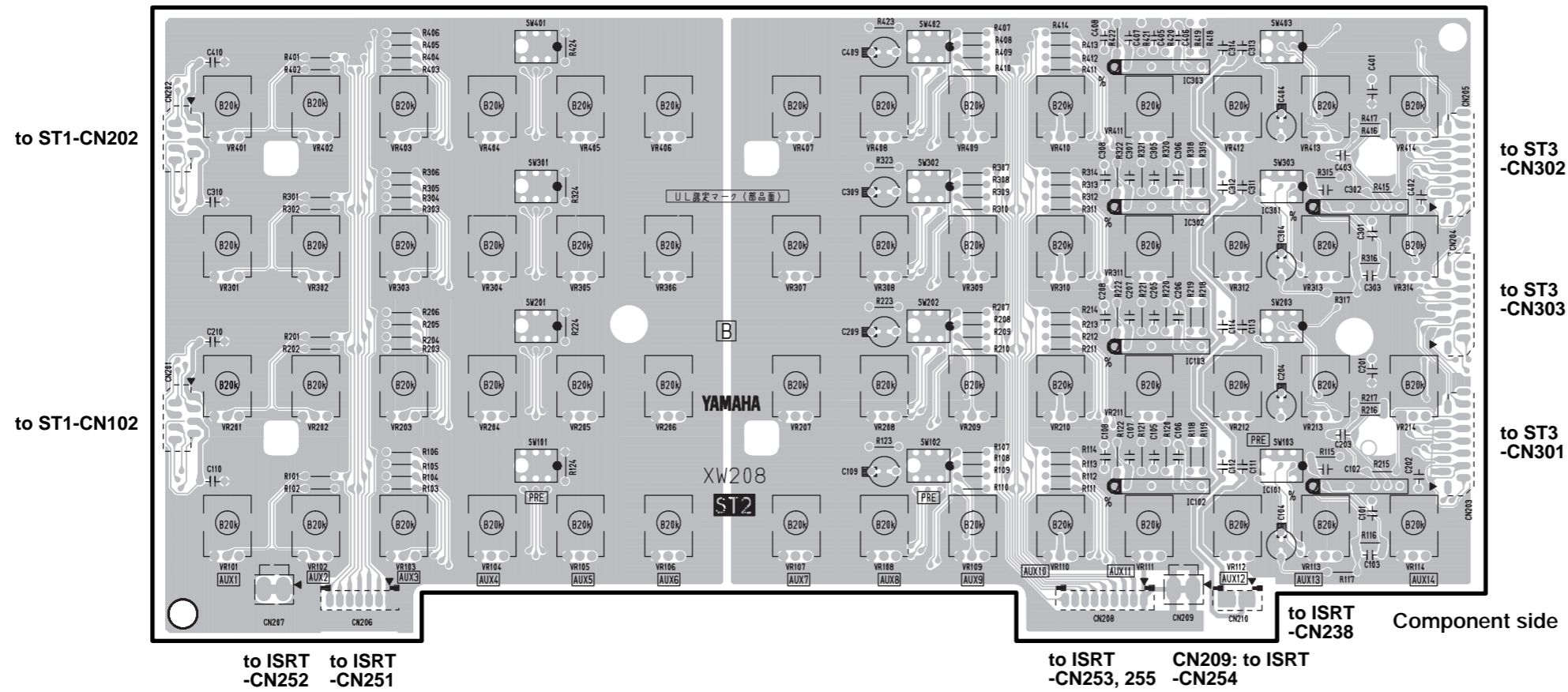

● ST3 Circuit Board

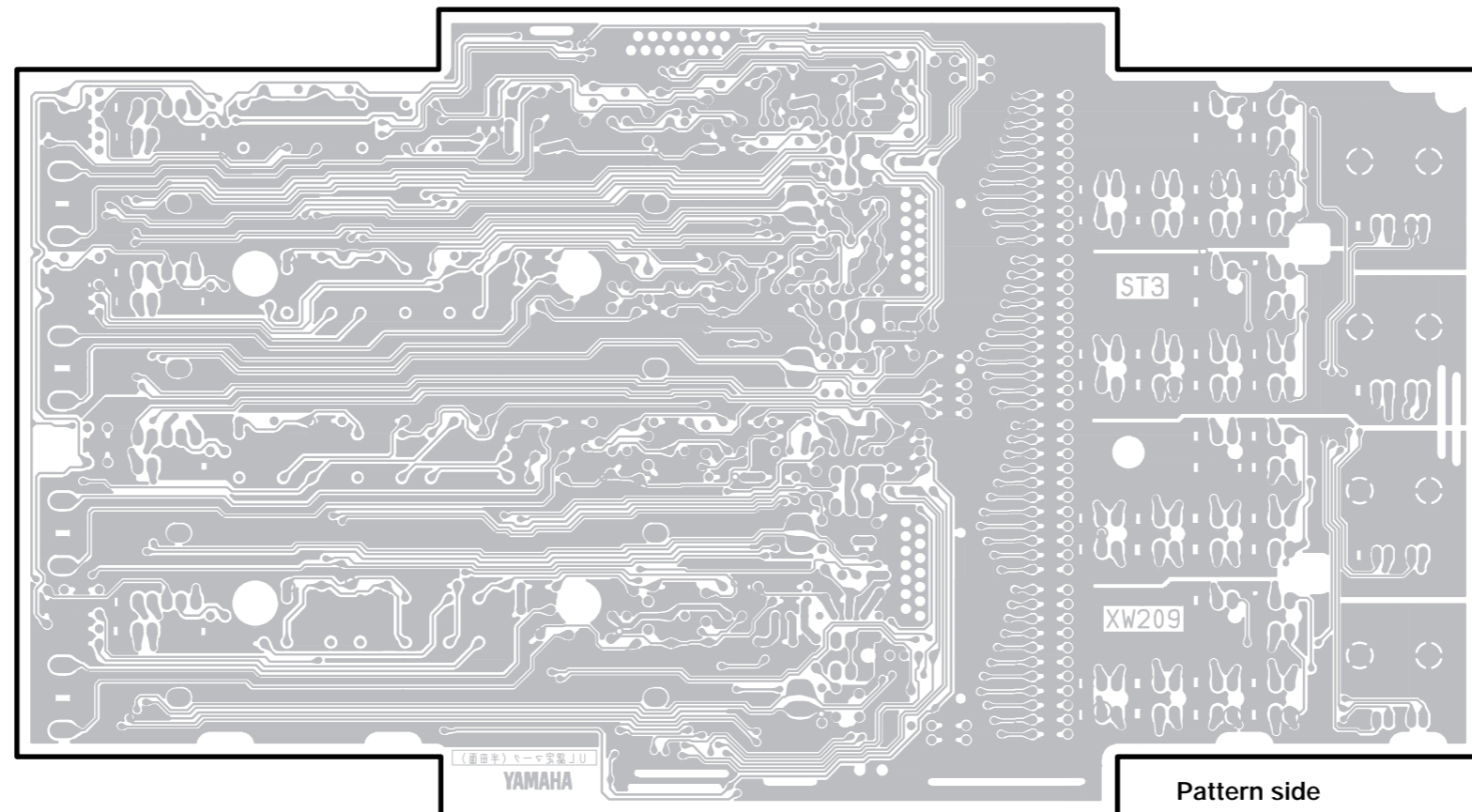
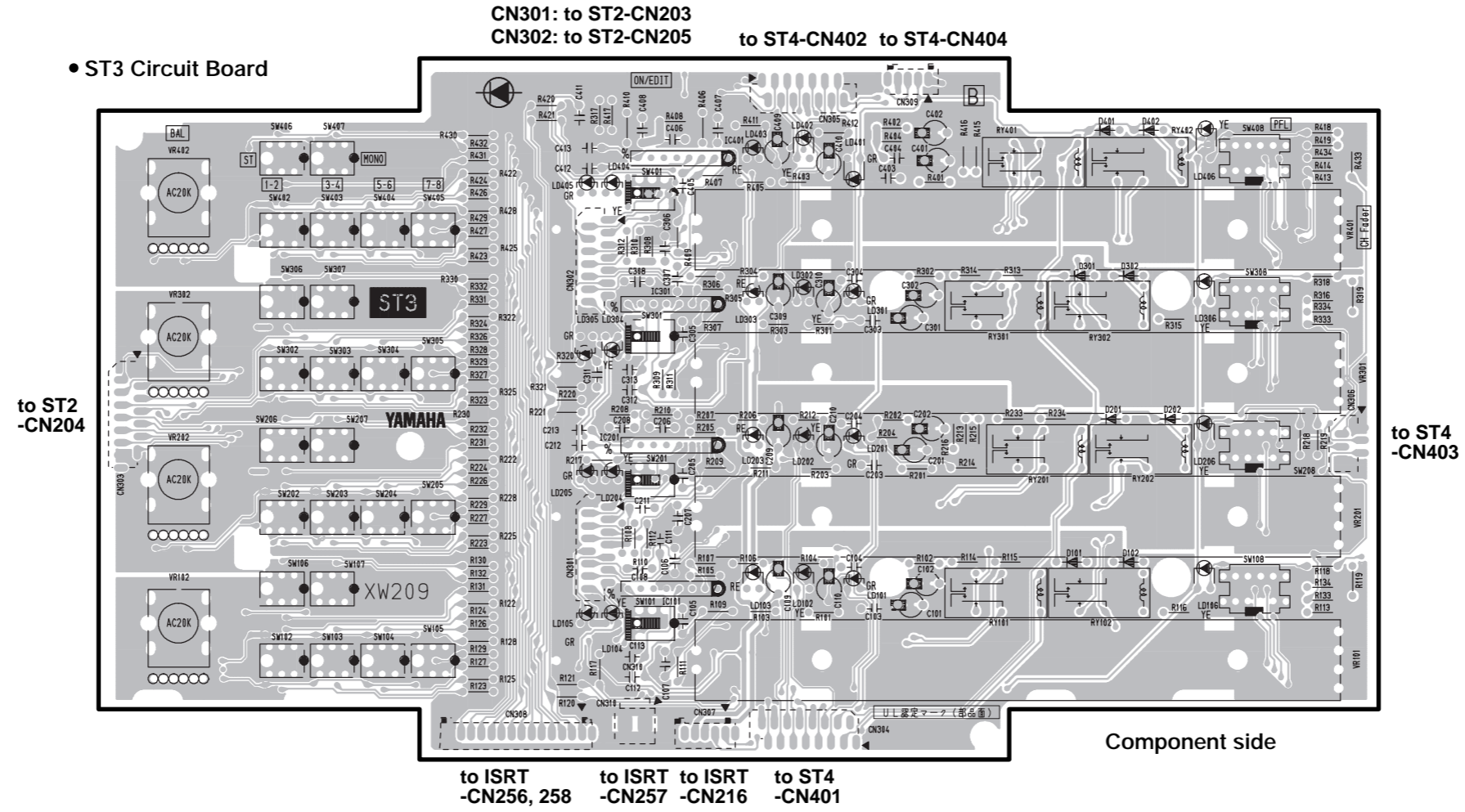

• ST4 Circuit Board

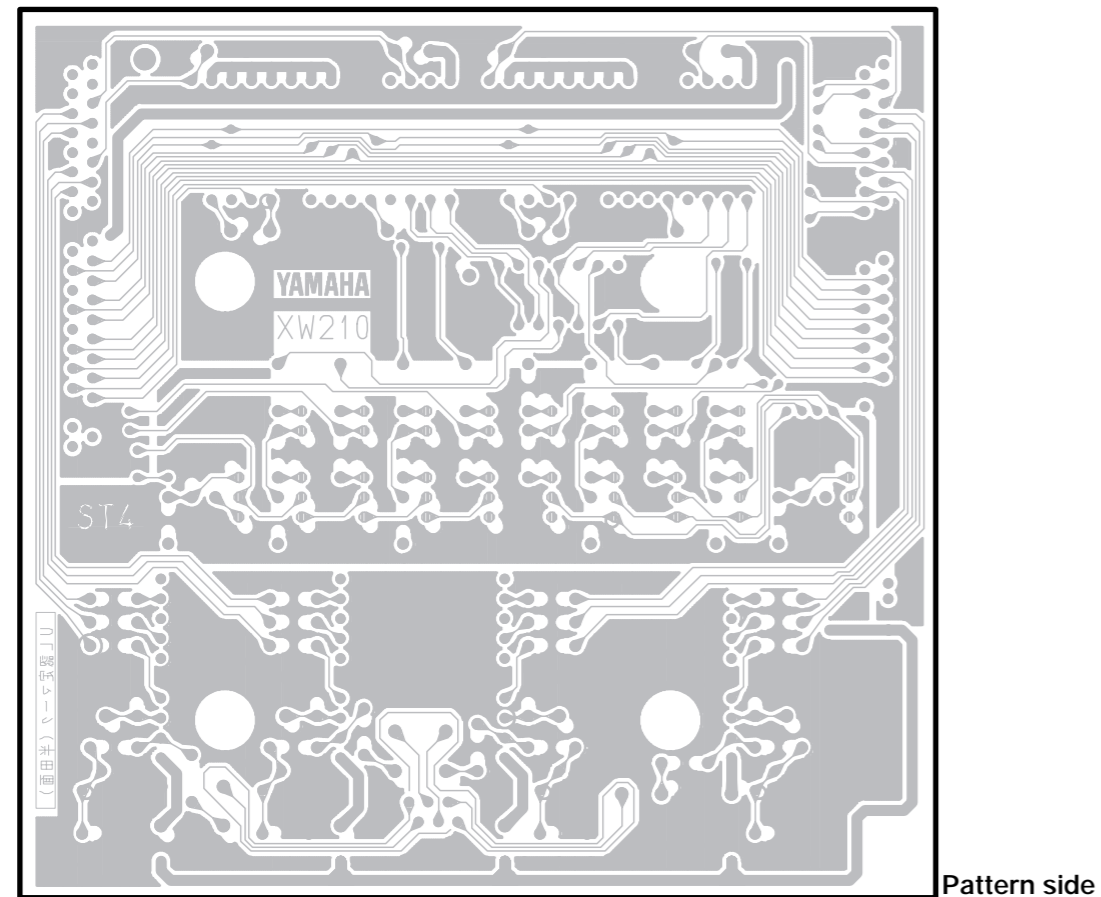
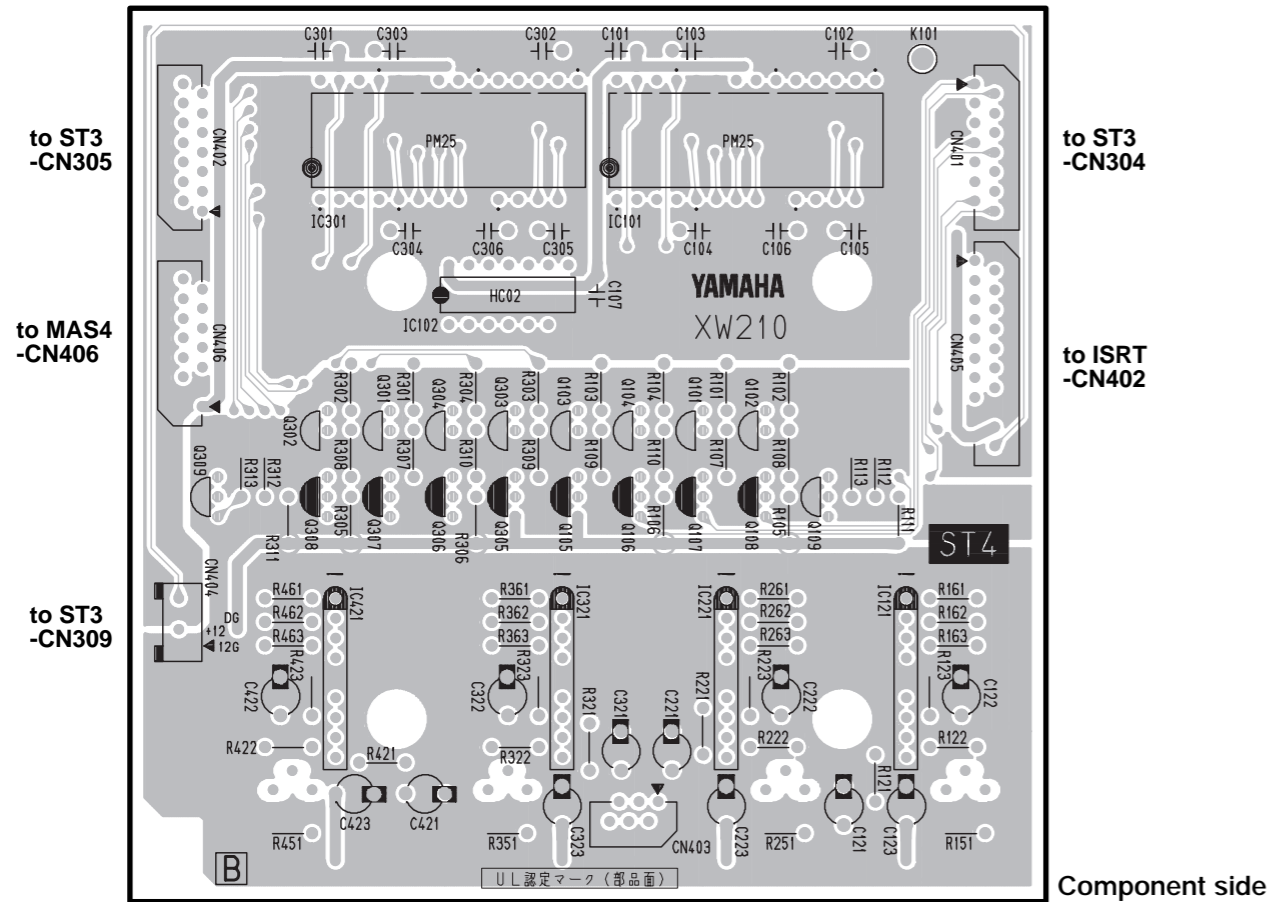

• STJK 1/2 Circuit Board

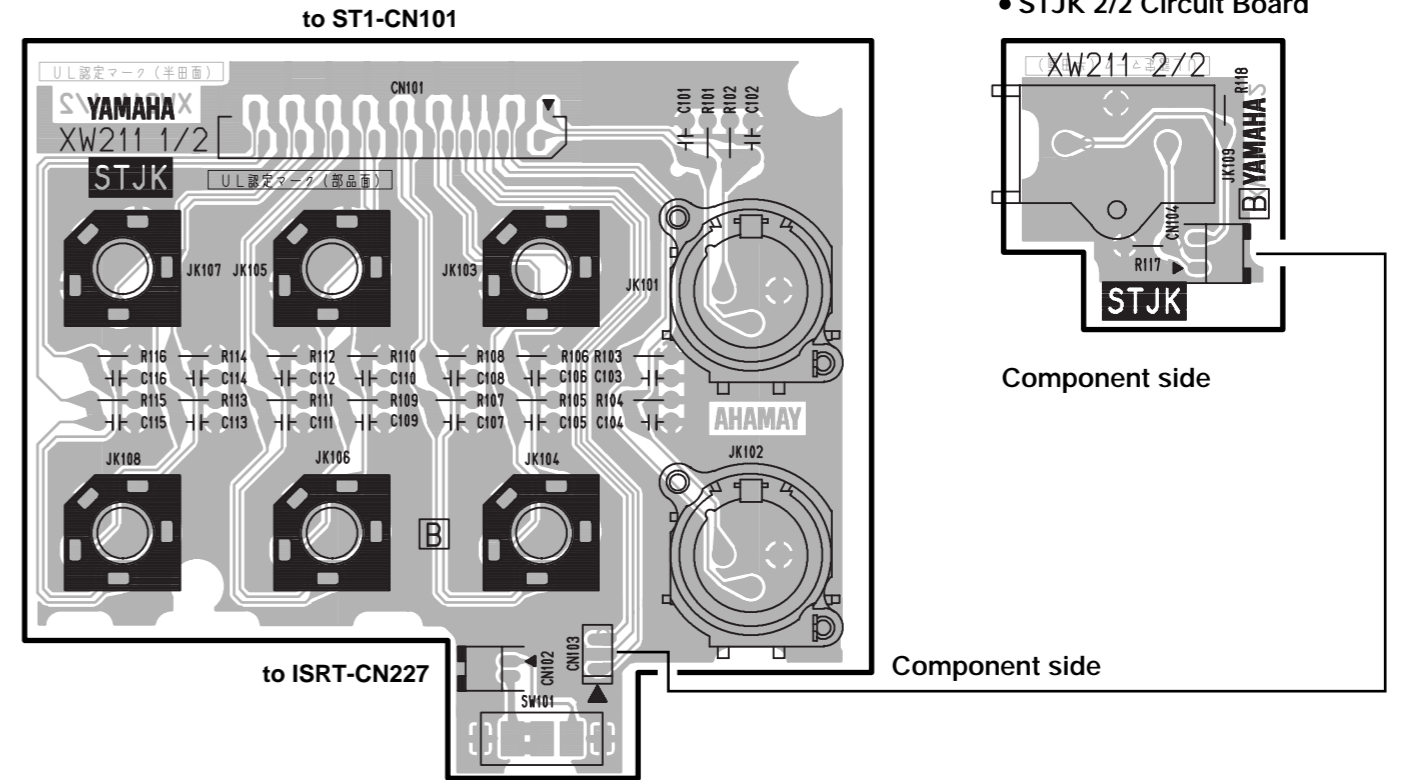

• STJK 2/2 Circuit Board

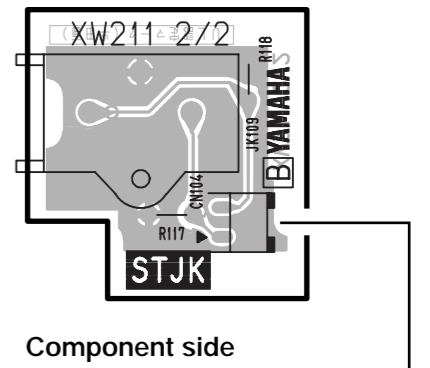

ST4: 3NA-V431400 ⚠
 STJK: 3NA-V431300 ⚠

INSPECTIONS

1. PREPARATIONS

- Connect the main unit and the power source (PW3000A) via the supplied DC power supply cable.
- Activate the test program and execute the channel version settings. (Refer to the TEST PROGRAM SECTION of this service manual.)
- Unless otherwise specified, the applied signal should be 1kHz, -70 dBs sine wave and the impedance of the signal source should be 150 ohms.
- The load resistance of each output terminal should be as follows.

PHONES (L, R) OUT	40 ohm (3W or less)
INSERT OUT	10k ohm
Other output	600 ohm
- The signal level referred to in these specifications is 0 dBs = 0.775 V.
- Unless otherwise specified, set the controls and switches as described under 1-1 to 1-16.

1-1 (CH 1-N) INPUT (N:24, 32, 40, 48, 56)

+48V switch	OFF
GAIN Trim	MAX (-60 dB)
26dB switch	OFF (0 dB)
ϕ switch	OFF (NORMAL)
/80(HPF ON) switch	OFF
HI, HI-MID, LO-MID, LO EQ Gain controls	CENTER
HI-MID, LO-MID EQ Freq. controls	MINI
EQ ON switch	OFF
AUX1-14 Level controls	MAX
AUX3-6, AUX7-10, AUX11-14 PRE switches	OFF (POST)
PAN control	L (maximum counterclockwise)
1-2, 3-4, 5-6, 7-8, ST.MONO Assign switches	ON: during measurement only, OFF: at all other times
LCR ON switch	OFF
ON/EDIT switch	Only measuring CH ON, all others OFF
PFL switch	ON: during measurement only, OFF: at all other times
Fade	MAX

1-2 ST INPUT 1

GAIN A Trim	MAX (-30dB)
GAIN B Trim	MAX (-20dB)
A/B	switch OFF (A)

1-3 ST INPUT 2-4

GAIN Trim	MAX
-----------	-----

1-4 ST INPUT 1-4

HI, LO EQ Gain controls	CENTER
EQ ON switch	OFF
AUX1-14 Level controls	MAX
AUX3-6, AUX7-AUX10, AUX11-AUX14 PRE switches	OFF (POST)
BAL control	L (maximum counterclockwise)
1-2, 3-4, 5-6, 7-8, ST, MONO Assign switches	ON: during measurement only, OFF: at all other times
ON/EDIT switch	Only measuring CH ON, all others OFF
PFL switch	ON: during measurement only, OFF: at all other times
Fader	MAX

1-5 GROUP/AUX FLIP

GROUP/AUX FLIP switch	OFF (GROUP)
-----------------------	-------------

1-6 AUX1-6 OUT

ON switch	ON: during measurement only, OFF: at all other times
AFL switch	ON: during measurement only, OFF: at all other times
Fader	MAX

1-7 AUX7/GROUP1~AUX4/GROUP8 OUT

ON switch
AFL switch
Fader

ON: during measurement only, OFF: at all other times
ON: during measurement only, OFF: at all other times
MAX

1-8 GROUP1/AUX7~GROUP8/AUX14 OUT

TO MATRIX switch
TO STEREO, MONO switches
TO LCRswitch
PAN control
ON/EDIT switch
AFL switch
Fader

ON: during measurement only, OFF: at all other times
ON: during measurement only, OFF: at all other times
OFF
L (maximum counterclockwise)
ON: during measurement only, OFF: at all other times
ON: during measurement only, OFF: at all other times
MAX

1-9 STEREO (L, R), MONO/C OUT

TO MATRIX switch
ON/EDIT switch
AFL switch
Fader

ON: during measurement only, OFF: at all other times
ON: during measurement only, OFF: at all other times
ON: during measurement only, OFF: at all other times
MAX

1-10 MATRIX (1~8) OUT

SUB IN L, SUB IN R Mix level controls
STEREO L, STEREO R, MONO/C Mix level controls
GROUP1/AUX7~GROUP8/AUX14 Mix level controls
ON switch
AFL switch
LEVEL control

MAX: during measurement only, MIN: at all other times
MAX: during measurement only, MIN: at all other times
MAX: during measurement only, MIN: at all other times
ON: during measurement only, OFF: at all other times
ON: during measurement only, OFF: at all other times
MAX

1-11 TALKBACK/ OSCILLATOR

PINK/10kHz/1kHz/100Hz Select and ON switches
AUX1-2, ••••, ST and MONO assign switches
OSC/TB level control
ON (TB) switch

ON: during measurement only, OFF: at all other times
ON: during measurement only, OFF: at all other times
MAX
TB ON: during measurement only, OFF: at all other times

1-12 MONITOR (L, R, MONO/C) OUT

MASTER PFL switch
L+R switch
ON switch
LEVEL control

OFF (AFL)
OFF (stereo)
ON: during measurement only, OFF: at all other times
MAX

1-13 PHONES (L, R) OUT

LEVEL control

MAX: during measurement only, MIN: at all other times

1-14 METER SELECT

MATRIX•A7-14/G1-8•A1-6•G1-8/A7-14 Select switches

G1-8/A7-14

1-15 SCENE MEMORY

UTILITY switch
RECALL switch
STORE switch
CHECK switch
0~9 and ENTER, △ (+1), ▽ (-1) switches
DIRECT RECALL (1 to 8) switches

OFF (should be reset to the initial state.)
OFF (should be reset to the initial state.)
OFF (should be reset to the initial state.)
OFF (should be reset to the initial state.)
OFF (should be reset to the initial state.)
N/A (not particularly specified.)

1-16 Others

PHANTOM MASTER switch

OFF

1-17 Measuring equipment

- The oscillator to be connected to the balanced input terminal should be a balanced output type with 150-ohm output impedance.
- The output impedance of the oscillator to be connected to the unbalanced input terminal should be less than 10 ohms.
- The input impedance of the oscilloscope and the level meter should be 100 k ohms or more.
- The noise level should be measured by using a 12.7 kHz, -6 dB/Oct. low-pass filter.
- The measuring instruments are required to be the balanced input type. If only an unbalanced input type measuring instrument is available, a drop in the maximum output level of the balance output terminal should be taken into consideration.

2. GAIN

In the state as described in 1., check that the output level measured at each output terminal is within the range given in Tables 2-1 to 2-10.

Table 2-1 Input Terminal CH INPUT (1 to 24, 32, 40, 48, 56)

Unit: [dBs]

Input Level	GAIN	26dB	AUX PRE	LCR	LCR PAN	GROUP /AUX FLIP	G1/A7~ G8/A14 OUT	STEREO (L<R) OUT *1	MONO/C OUT	AUX1, 2 OUT	AUX3~6 OUT	A7/G1~ A14/G8 OUT	MONITOR (L, R) OUT *2
-70	MAX	OFF	OFF	OFF	-	OFF	+14 ± 2 *1	+14 ± 2	+14 ± 2	+10 ± 2	+20 ± 2	+16 ± 2	0 ± 2
			ON *3	OFF	-	OFF	---	---	---	---	---	---	+10 ± 2 *1
-44	MAX	ON	OFF	OFF	-	OFF	---	+14 ± 2 *6	---	---	---	+10 ± 2 *4	+6 ± 2 *5
			ON	OFF	-	OFF	---	+14 ± 2 *6	---	---	---	---	---
-26	MIN	OFF	OFF	OFF	L	---	---	+14 ± 2 *6	---	---	---	---	---
						---	---	+14 ± 2 *6	---	---	---	---	
						ON *8	---	---	+14 ± 2	---	---	---	
						Center	---	---	+14 ± 2 *7	---	---	---	
					R	---	---	---	---	---	---	---	

*1 In the case of “L” and odd number “OUT”, turn the PAN control to the “L” position and in the case of “R” and even number “OUT”, turn it clockwise to lthe maximum position.

*2 When the PFL switch is turned on, the INPUT (CUE) LEDs in the CH PFL and MASTER sections will light up.

*3 When the GROUP/AUX FLIP switch is turned off, the GROUP LED will light up and when it is turned on the AUZ LED will light up.

*4 Measure the AUX3 OUT only.

*5 Measure the A7/G1 and A11/G5 OUT only.

*6 Measure the STEREO L OUT only.

*7 Measure the STEREO R OUT only.

*8 When the LCR switch is turned on, the LCR LED will light up.

- The level difference between the following CH INPUTs of each output should be 2 dB or less; between G1/A7 ~ G8/A14, STEREO L and R, AUX 1 and 2, AUX 3 ~ 6, A7/G1 ~ A14/G8, and MONITOR (L and R).

Table 2-2 Input Terminal CH INPUT/CH INSERT IN (1 to 24, 32, 40, 48, 50)

Unit: [dBs]

Input Terminal	Input Level	GAIN	26dB	CHINSERT OUT	STEREO A(L)OUT
CH INPUT	-16	MIN	OFF	0.0+/-2.0	---
CH INSERT IN	-10	---	---	---	+14.0+/-2.0

- The level difference between the CH (1 to 24, 32, 40, 48, 56) of each output should be 2 dB or less.

Table 2-3 Input Terminal ST CH INPUT (1 to 4)

Unit: [dBs]

Input Terminal	Input Level	GAIN	A/B	AUX PRE	BAL	G1/A7, G3/A9, G5/A11, G7/A13 OUT	G2/A8, G4/A10, G6/A12, G8/A14 OUT	STEREO L OUT	STEREO R OUT	MONO/C OUT	AUX1, 2 OUT	AUX3~6 OUT	A7/G1~ A14/G8	MONITOR L OUT *1	MONITOR R OUT *1
1A L	40	MAX	OFF(A)	OFF	L	+14 ± 2	---	+14 ± 2	---	10.5 ± 2	+6.5 ± 2	+16.5 ± 2	+12.5 ± 2	0 ± 2 *5	---
				ON	---	---	---	---	---	---	---	---	---	---	
1A R	0	MIN		OFF	R	---	+14 ± 2	---	+14 ± 2	+10 ± 2	+6.5 ± 2	+16.5 ± 2 *3	---	---	0 ± 2
1A L				L	---	---	+14 ± 2	---	---	---	---	---	---	---	
1A R				OFF	R	---	---	+14 ± 2	---	---	---	---	---	---	---
1B L	-30	MAX	ON(B)	OFF	L	---	---	+14 ± 2	---	---	---	---	---	---	---
					R	---	---	+14 ± 2	---	---	---	---	---	---	
1B R	0	MIN		OFF	L	---	---	+14 ± 2	---	---	---	---	---	---	---
1B R					R	---	---	+14 ± 2	---	---	---	---	---	---	
2~4 L	-40	MAX	---	OFF	L	+14 ± 2	---	+14 ± 2	---	+16.5 ± 2	+12.5 ± 2.5	+22.5 ± 2.5	+18.5 ± 2.5	0 ± 2 *5	0 ± 2
				ON	---	---	---	---	---	---	---	---	---	---	
2~4 R	0	MIN		OFF	R	---	+14 ± 2	---	+14 ± 2	---	---	+12.5 ± 2.5 *3	+8.5 ± 2.5 *4	---	---
				OFF	R	---	---	---	+14 ± 2	---	---	---	---	---	
2~4 L				OFF	L	---	---	+14 ± 2	---	---	---	---	---	---	
				OFF	R	---	---	---	+14 ± 2	---	---	---	---	---	

*1 Turn on the PFL switch.

*2 Measure the AUX1 only.

*3 Measure the AUX3 only.

*4 Measure the A7/G1 and A11/G5 only.

*5 The PFL LED and the INPUT (CUE) LED in the MASTER section will light up.

- The level difference between ST CH INPUT (1 to 4) of each output should be 2 dB or less.
- The level difference between STEREO L and R, AUX 1 and 2, AUX3 ~ 6, A7/G1 ~ A14/G8 and MONITOR L and R should be 2 dB or less.

Table 2-4 Input Terminal SUB IN (STEREO L, R, MONO/C) Unit: [dBs]

Input Terminal	Input Level	L+R	STEREO L OUT	STEREO R OUT	MONO/C OUT	PHONES	
						L	R
SUB IN STEREO L	+4	OFF	+13.5+/-2	+13.5+/-2	+13.5+/-2	---	---
SUB IN STEREO L	-16	OFF	---	---	---	-2.5+/-2	---
		ON	---	---	---	-6+/-2	-6+/-2
SUB IN STEREO R		OFF	---	---	---	---	-2.5+/-2
		ON	---	---	---	-6+/-2	-6+/-2

- The level difference between STEREO L and R should be 2 dB or less.

Table 2-5 Input Terminal MASTER INSERT IN (AUX1 ~ AUX6, G1/A7 ~ G8/A14, STEREO L and R, MONO/C) Unit: [dBs]

Input Terminal	Input Level	AUX1~AUX6, G1/A7~G8/A14, STEREO L, R, MONO/C OUT
AUX1~AUX6, G1/A7~G8/A14, STEREO L, R, MONO/C INSERT IN	0	+14+/-2

- The level difference between AUX1 ~ AUX6, G1/A7 ~ G8/A14, STEREO L and R should be 2 dB or less.

Table 2-6 Input Terminal TALKBACK IN Unit: [dBs]

Input Level	AUX1~AUX6~ASTEREO L, R~A MONO/C OUT	A7/G1~A14/G8 OUT
-60	-10+/-2	+6+/-2

- The level difference between AUX1 ~ AUX6, STEREO L and R, A7/G1 ~ A14/G8 should be 2 dB or less.

Table 2-7 Input Terminal INSERT IN (STEREO L and R, MONO/C) Unit: [dBs]

Input Terminal	Input Level	AFL	MASTER PFL	MATRIX	MONITOR(L, R)OUT			MATRIX(1-8) OUT *2
					L	R	C	
INSERT IN STEREO L	-10	OFF	OFF	OFF	+10+/-2			
		ON *1	OFF		+10+/-2			
		ON	ON		0+/-2			
INSERT IN STEREO R		OFF	OFF	ON				+10+/-2
		ON *1	OFF	OFF		+10+/-2		
		ON	ON	0+/-2				
INSERT IN MONO/C		OFF	OFF	ON			+10+/-2	
		ON *1	OFF	OFF	+4+/-2	+4+/-2		
		ON	ON	OFF	-6+/-2	-6+/-2		
		OFF	OFF	ON				+10+/-2

*1 The AFL LED and the MASTER (CUE) LED in the MASTER section will light up.

*2 Turn all the STEREO L and R, MONO/C Mix level controls of MATRIX (1 ~ 8) to the MAX position.

- The level difference between MONITOR L and R, MATRIX (1 ~ 8) should be 2 dB or less.

Table 2-8 Input Terminal INSERT IN (G1/A7 ~ G8/A14) Unit: [dBs]

Input Terminal	Input Level	G1/A7 ~ G8/A14 MASTER section (MONITOR MASTER section for MASTER PFL)							MONITOR L OUT	MONITOR R OUT	STEREO L OUT	STEREO R OUT	MONO/C OUT	MATRIX(1-8) OUT *4	
		AFL	MONITOR PFL	ST	PAN control	MONO/C	LCR	MTRX							
INSERT IN G1/A7~G8/A14	-10	ON *1	OFF	OFF	---	OFF	OFF	OFF	+10+/-2	+10+/-2 *2	---	---	---	---	
		ON	ON	---	---	---	---	---	0+/-2	---	---	---	---	---	
		OFF	OFF	ON	L	ON	---	---	---	---	---	+14+/-2	---	---	---
				R	---					---	---	---	---		
		OFF	OFF	OFF	L	OFF	ON *3	---	---	---	---	+14+/-2	---	---	---
					Center	---	---			---	---	---	---		
					R	---	---	---	---	---	---	---	---	---	---
					---	---	---	---	---	---	---	---	---	---	---
					---	---	---	---	---	---	---	---	---	---	---
			---	---	---	---	---	---	---	---	---	---	---		
			---	---	---	---	---	---	---	---	---	---	---		
			---	---	---	---	---	---	---	---	---	---	---		

- *1 The AFL LED and the MASTER (CUE) LED in the MASTER section will light up.
- *2 Measure the G1/A7 input only.
- *3 The LCR LED will light up.
- *4 Turn all the G1/A7 ~ G8/A14 Mix level controls of MATRIX (1 ~ 8) to the MAX position.

- The level difference between STEREO L, R, MONITOR L, R, MATRIX (1 ~ 8) should be 2 dB or less.

Table 2-9 Input Terminal INSERT IN (AUX1 ~ 6), TALKBACK IN, MATRIX SUB IN (L, R) Unit: [dBs]

Input terminal	Input level	Equivalent to AFL	MASTER PFL	TALKBACK assign	MONITOR L OUT	MONITOR R OUT	MATRIX (1~8) OUT *3
INSERT IN (AUX1~6)	-10	AUX1~6	OFF	OFF	+10+/-2	+10+/-2 *2	---
		ON *1	ON		0+/-2	---	---
TALKBACK IN	-60	AUX7~14	OFF	A7-A10,	+12+/-2	---	---
		ON *1 *4	ON	A11-A14 ON	+6+/-2	---	---
MATRIX SUB IN L	-6	OFF	OFF	---	---	0+/-2	---
		MTRX1~8	---	---	-6+/-2	---	---
		ON *1	ON	OFF	0+/-2	---	---
MATRIX SUB IN R		OFF	OFF		---	---	0+/-2

- *1 The AFL LED and the MASTER (CUE) LED in the MASTER section will light up.
- *2 Measure the AUX1 input only.
- *3 Turn all the SUB IN L, R Mix level controls of MATRIX (1 to~ 8) to the MAX position.
- *4 Turn on AUX7 ~ AUX14 one by one.

- The level difference between MONITOR L, R, MATRIX (1 ~ 8) should be 2 dB or less.

3. FREQUENCY RESPONSE

- In the state as described in 2., apply the signals of 20 Hz and 20kHz frequency, and check that the output level of each output terminal is within the range of +0.5 dB -2.5 dB with 1 kHz used as a reference.
- Measure STEREO L, R OUT only in Table 2-3 ST CH INPUT.
- Measure INSERT IN G1/A7 input only in Table 2-8 INSERT IN ~ MATRIX (1 ~ 8) OUT.
- Measure the value via A7 only in Table 2-9 TALKBACK IN ~ MONITOR L OUT.

4. EQ CHANGE CHARACTERISTICS

- In the state as described in 1, turn on the EQ switch, move each EQ control and check that the output level of the frequency obtained at STEREO L OUT falls within the range given in Tables 4-1 and 4-2 with the output level obtained when the EQ GAIN control is set at the center click position used as a reference.
- If the output level of the specified frequency is out of the specified range, vary the frequency of the applying signal within ± 20% of the specified frequency and check that the output level is as specified in Tables 4-1 and 4-2.

Table 4-1 CH INPUT (1 to 24, 32, 40, 48, 56) EQ Unit: [dB]

Input	GAIN	EQ	EQ GAIN	f-VR	Applied signal frequency	Variation width
-40dBs	MIN	HI	MAX	---	10kHz	+12+/-2
			MIN			-12+/-2
		HI-MID	MAX	MIN	400Hz	+15+/-2.5
			MIN			-15+/-2.5
			MAX	MAX	8kHz	+15+/-2.5
			MIN			-15+/-2.5
		LO-MID	MAX	MIN	80Hz	+15+/-2.5
			MIN			-15+/-2.5
			MAX	MAX	1.6kHz	+15+/-2.5
			MIN			-15+/-2.5
		LO	MAX	---	100Hz	+12+/-2
			MIN			-12+/-2

Table 4-2 INPUT (1 to 4) EQ

Unit: [dB]

INPUT	GAIN	EQ	EQ GAIN	Applied signal frequency	Variation width
-10dBs	MIN	HI	MAX	10kHz	+12+/-2
			MIN		-12+/-2
		LO	MAX	100Hz	+12+/-2
			MIN		-12+/-2

5. HPF CHANGE CHARACTERISTICS

- In the state as described in 1, set the input level to -40 dBs, Gain to the MIN. position and the input frequency to 80 Hz. Then turn on the CH INPUT /80 switch and check that the output level of STEREO L OUT is within the range of -3 ± 2 dB with the level provided when the switch is turned off used as a reference.

6. SEPARATION

- In the state as described in 1, turn on the CH INPUT ST switch and set the STEREO L OUT output level to +20 dBs and check that the leakage level to the STEREO R OUT is -50 dBs or less.
- Also, Turn the PAN control clockwise to the maximum position and set the output level of the STEREO R OUT to +20dBs and check that the leakage level to the STEREO L OUT is -50 dBs or less.

7. LED (SIGNAL, NOM, PEAK) LIGHT-UP LEVEL

- In the state as described in 1, apply a signal to the input terminal of ST CH INPUT and check that input level at which each LED lights up is within the range specified in Table 7.

Table 7 LED

Unit: [dBs]

Input terminal	GAIN control	LED		
		SIGNAL	NOM	PERK
CH INPUT	MIN	-29+/-3.5	-16+/-2.5	+1+/-3
ST CH INPUT 1A L	MAX	-40 +4.5 -3.5	-27+/-2.5	-10+/-3
ST CH INPUT 1A R	MIN			
ST CH INPUT(2~4) L *1	MAX	-46 +4.5 -3.5	-33+/-2.5	-16+/-3

*1 Nothing should be inserted in ST CH INPUT (2 ~ 4).

8. DISTORTION FACTOR

- In the state as described in 1, set each VR of INPUT and MASTER and FADER to the Nominal position and the INPUT GAIN Trim to the MIN position even if it is instructed to set the GAIN Trim to the MAX position and apply a signal from CH INPUT•ST CH INPUT A.
- Check that the distortion factor when a +14 dBs output is obtained at each output terminal is 0.03% or less.
- Check that the distortion factor when a +3 dBs output is obtained at PHONES (L, R) OUT is 0.1% or less.
- Measure STEREO L, R OUT only in Table 2-3 ST CH INPUT.
- Measure INSERT IN G1/A7 input only in Table 2-8 INSERT IN ~ MATRIX (1 ~ 8).
- Measure the value via A7 only in Table 2-9 TALKBACK IN ~ MONITOR L OUT. Check that the distortion rte is 0.05% or less.

9. MAXIMUM OUTPUT

- In the state as described in 1, check that a +24 dBs output with 1% or less distortion factor is obtained at each output terminal of STEREO (L, R) OUT, MONO/C OUT, GROUP/AUX7 ~ GROUP8/AUX14 OUT, AUX1 ~ AXU6 OUT, AUX7/GROUP8 OUT, MATRIX (1 ~ 8) OUT and MONITOR (L, C, R) OUT.
- Check that a +7.5 dBs output with 1% or less distortion factor is obtained at PHONES (L, R) OUT.

10. VU METER

- Check that when the output level of GROUP1/AUX7 ~ GROUP8/AUX14 OUT, STEREO L, R OUT and MONO/C OUT is +4 dBs, the indication on the corresponding VU meter is 0 ± 1 VU.
- Check also that the difference in the values indicated on each meter R is 1 VU or less between GROUP1/AUX7 ~ GROUP8/AUX14 and between STEREO L.
- Next, set the METER SELECT switch to AUX1 - 8, AUX7 - 14/GROUP 1 - 8 and MATRIX positions respectively and check that the indication on the corresponding VU meter is 0 ± 1 VU.

- Input a signal from CH1, turn on the PFL switch of CH1 and check that the indication on the VU meter of PFL/AFL L, R is 0 ± 1 VU when the output of the MONITOR L, R is +10 dBs.
- Return the METER SELECT switch to the G1/A7 ~ G8/A14 position and check that the output of GROUP1/AUX7 ~ GROUP8/AUX14 OUT, STEREO L, R OUT, MONO/C OUT is within the range of $+21 \pm 2$ dBs and the PEAK LED built in the corresponding VU meter lights up.
- Also, check that the light in the VU meter remains on when the power switch is on.

11. RESIDUAL NOISE

- In the state as described in 1, set all FADER and level controls to the MIN position and turn off the switch.
- Set each of the MASTER Fader and MASTER LEVEL controls to the MAX or MIN position and check that the noise level is at the level indicated in Table 11 or less.

Table 11 Residual Noise

Unit: [dBs]

MASTER Fader & MASTER LEVEL	STEREO L, R, MONO/C OUT	G1/A7~ G8/A14 OUT	AUX1~6 OUT	A7/G1~ A14/G8 OUT	MATRIX 1~8 OUT	MONITOR L, C, R OUT *1
MAX	-70.0	-71.0	-65.0	-69.0	-84.0	-91.0
MIN	-98.5	-98.5	-98.5	-100.0	-100.0	-100.0

*1 When measuring LEVEL control MAX of the MONITOR L, C, R OUT set the STEREO, MONO/C MASTER Fader to the MIN position.

12. NOISE LEVEL

- In the state as described in 1, short-circuit the input terminal of CH INPUT with 150 ohm, check that the noise level at the STEREO L OUT is -42.5 dBs or less.
- * If the noise level is more than -42.5 dBs, find the noise level by using an input conversion and check that it is -126.5 dBs or less.

13. PHASE

- Check that the phase of the signal applied to each input terminal and that of the signal obtained at each output terminal are the same.

Pin arrangement for balanced type input/output terminal

PIN1----- GND

PIN2----- + (HOT)

PIN3----- - (COLD)

- Check that the phase is reversed when the PHASE switch of the CH INPUT is turned on and that the level difference resulting from turning off and on of the PHASE switch is within ± 1.0 dB.

14. OSCILLATOR

- In the state as described in 1, set the TB/OSC LEVEL control of the TALKBACK to the MAX position and turn on the ST assign switch.
- Turn on each of 100 Hz, 1 kHz, 10 kHz and PINK switches of the OSCILLATOR and check that the output level of the signal obtained at the STEREO L OUT is $+16 \pm 2, 5$ dBs.
- Also, check that the signal obtained when each of 100 Hz, 1 kHz and 10 kHz switches is turned on has a frequency within $\pm 10\%$ and a distortion factor of 1% or less.

15. PHANTOM

- Connect a 10k ohms (1W or more) load resistance between pins 1 and 2 of the input terminal of each CH INPUT and short-circuit between pins 2 and 3.
- Turn on the PHANTOM MASTER switch and then the +48 V (PHANTOM) switch of the channel being measured and check that a $+35 \pm 3$ V voltage is obtained at both ends of the load resistance.
- Check that the +48V LED lights up when the +48 V (PHANTOM) switch is turned on.

16. ON LED

- Check that when the TALKBACK and MONITOR switches are turned on, the corresponding LED lights up.

17. VOLTAGE MONITOR LED

- Check that +15, -15 and +12 LEDs are on.
- Check that the PHANTOM MASTER LED lights up when the PHANTOM MASTER switch is turned on and it goes off when the switch is turned off.

18 POWER SUPPLY FOR LIGHTING

- Check that the voltage at the pin 3 (+) to pin 4 (-) of the power supply connector (XLR-4P) for lighting on the meter panel is $12 \text{ V} \pm 3 \text{ V}$.

19. Maximum attenuation of FADER

- With each fader set at the MAX position, have +20 dB signals output at each output terminal. Then lower fully each fader in CH INPUT, ST CH INPUT and MASTER sections fully and check attenuation. It should be -70 dB or less.
- As ST INPUT and ST MASTER are two consecutive faders, be sure to perform the same check for both L and R. (It is also possible to take measurements by using the DIN AUDIO filter and cutting off the noise.)

20 STABILITY

- Check that varying the power supply voltage by $\pm 10\%$ of the specified value does not cause any problem in operation.

21 OSCILLATION

- Check that no problem such as oscillation occurs even when a capacitor of 10 pF to 0.1 uF is connected in parallel with the load resistance at each output terminal.
- Also, check that no problem such as oscillation occurs even when the fader, level controls and EQ control except the Mix level control of MATRIX are all set to the MAX position. For this check, short-circuit the input terminal with 150 ohms.

■ TEST PROGRAM

A. TEST PROGRAM

(1) CTRL SECTION LED TEST	Test number 1
(2) CTRL SECTION SWITCH TEST	Test number 2
(3) CHANNEL VERSION SETTING TEST	Test number 24 (24 CH)
	Test number 32 (32 CH)
	Test number 40 (40 CH)
	Test number 48 (48 CH)
	Test number 56 (56 CH)
(4) LOCAL MODE SWITCH, LED TEST	Test number 3
(5) EXIT	Test number 9
(6) FACTORY SETTING	Test number 4
(7) VERSION DISPLAY	Test number 5

- The battery check is automatically performed when the test program is initiated and the measured voltage is displayed on the 7-SEG LED.

The new battery voltage is from 3.0 V to 3.5 V.

B. HOW TO ENTER THE TEST PROGRAM

Turn on the power while pressing the DIRECT RECALL 6, 7 and 8 keys, and the test program will be initiated.

C. HOW TO SELECT THE TEST PROGRAM

By using the \triangle (UP) and ∇ (DOWN) keys of the CTRL section, have "di*(d**)" and the desired sequence number displayed on the 7-SEG LED and confirm it by pressing the RECALL key.

Note: ** represents the sequence number.

D. OPERATION AND CONFIRMATION OF THE TEST PROGRAM

1. CTRL SECTION LED TEST

- Using the \triangle (UP) and the ∇ (DOWN) keys, have "di1" displayed on the 7-SEG LED.
- Press the RECALL key.
- " 8.", " 8. ", "8. ", "000", "111", "222", "333", "444", "555", "666", "777", "8.8.8.", UTILITY, CHECK, DIRECT RECALL 1 to 8 are indicated on the LED one after another.
- Check that all LEDs light up properly.
- After that, all LEDs go out for about 3 seconds and "di1" appears again.

2. CTRL SECTION SWITCH TEST

- Using the \triangle (UP) and the ∇ (DOWN) keys, have "di2" displayed on the 7-SEG LED.
- Press the RECALL key.
- Press the switches according to the indication on the 7-SEG LED.
The order is: UTILITY: "ut", RECALL: "rC", STORE: "St", CHECK: "CH", 1: "1", 2: "2", 3: "3", 4: "4", 5: "5", 6: "6", 7: "7", 8: "8", 9: "9", 0: "0", DIRECT RECALL1: "d1", DIRECT RECALL2: "d2", DIRECT RECALL3: "d3", DIRECT RECALL4: "d4", DIRECT RECALL5: "d5".
- When all the switches have been pressed and the test results are OK, "di2" appears on the 7-SEG LED.
To cancel the test while it is being executed, press the DIRECT RECALL8 key. When "nG2" appears on the 7-SEGLED, the test is finished.

3. SWITCH AND LED CHANNEL VERSION TESTS

- Using the \triangle (UP) and the ∇ (DOWN) keys, have "d24" displayed on the 7-SEG LED when using the 24 CH, "d32" for 32 CH, "d40" for 40 CH, "d48" for 48 CH and "d56" for 56 CH.
- Have the same one as the channel version displayed and press the RECALL key.
- The CH1 CHECK LED lights up.
- Press the CH1 ON/EDIT switch, and the CHECK LED will go out and the ON LED will light up. Also, when the switch is released, the CHECK LED of the next item to be checked will light up.

- Press the switches that have CHECK LEDs in the following order starting from CH1.
Order: CH1 to 24, 32, 40, 48, 56, ST CH1 to 4, G1/A7 to G8/A14, MONO/C, STEREO
- Check that lights of LEDs turn on and off properly.
- When the test has been successfully completed, the test can proceed to the next mode.
To cancel the test while it is being executed, press the ST A ON/EDIT switch. When "n24", "n32", "n40", "n48" or "n56" appears on the 7-SEG LED, the test is finished.

4. SWITCH AND LED LOCAL MODE TESTS

- Using the \triangle (UP) and ∇ (DOWN) keys, have "di3" displayed on the 7-SEG LED.
- Press the RECALL key.
- By pressing each ON/EDIT switch, check that the ON LED lights up and goes off properly.
- When all ON/EDIT switch tests have been completed, press the RECALL switch and the test will be finished.

5. EXIT

- Using the \triangle (UP) and ∇ (DOWN) keys, have "di9" displayed on the 7-SEG LED.
- Press the RECALL key.
- If the test has not been finished, "nG9" appears on the 7-SEG LED.

6. FACTORY SETTINGS

- Using the \triangle (UP) and ∇ (DOWN) keys, have "di4" displayed on the 7-SEG LED.
- Press the RECALL key.
- "SEt" appears on the 7-SEG LED.
- Press the STORE key and the display on the 7-SEG LED changes to "---" and the data below will be initialized to factory settings.

1. MEMORY PROTECT	[OFF]	8. MIDI ECHO BACK	[OFF]
2. OPERATION MODE	[DIRECT RECALL]	9. MIDI BULKDUMP REQUEST	[ALL]
3. MEMORY INITIALIZE	[ALL]	10. SCENE MEMORY(1, 3, 5, 7)	[ALL ON]
4. MIDI CH	[1]	11. SCENE MEMORY(2, 4, 6, 8)	[ALL OFF]
5. MIDI PROGRAM	[ON]	12. SCENE MEMORY(9~128)	[NO DATA]
6. MIDI CONTROL CHANGE	[ON]	13. ON/EDIT SW	[ALL ON]
7. PROGRAM CHANGE Rx OMNI	[OFF]	14. 7-SEG LED NUMBER	[1]

7. VERSION DISPLAY

Using the \triangle (UP) and ∇ (DOWN) keys, have "di5" displayed on the 7-SEG LED.
Press the RECALL key and the version will be indicated on the 7-SEG LED.

■ ERROR MESSAGES

While the M2500 is being operated or when the power is turned on, the MEMORY display may show one of the following error messages. If this occurs, refer to the corresponding explanation and take appropriate action.

<i>rEr</i>	An error occurred while receiving MIDI data. If an error occurs while receiving MIDI data, this error message will be displayed for several seconds.
<i>bFL</i>	The memory buffer became full while transmitting/receiving MIDI data. If the memory buffer becomes full while transmitting/receiving MIDI data, this error message will be displayed for several seconds. If this message appeared while transmitting MIDI data, turn the Utility item Eb (MIDI echo back) "OFF."
<i>PrO</i>	A scene memory store operation was executed or bulk dump data was received when memory protect was on. If you attempt to store a scene memory or if bulk dump data is received when memory protect was on, this error message will be displayed for several seconds.
<i>CHÉ</i>	A check sum error occurred while receiving bulk dump data. If a check sum error occurs while MIDI data is being received as a bulk dump, this error message will be displayed for several seconds. Check that the MIDI cable connections and the state of the transmitting device are appropriate.

<i>L0</i>	The voltage of the internal battery has fallen below the nominal level (2.5 V), or has become abnormal. If the voltage of the internal battery falls below the nominal value of 2.5 V or if the battery malfunctions, this error message will be displayed when the power is turned on. (When this message is displayed, you can press any switch to return to the normal state.) If this message appears, the battery replaced. The voltage of the internal battery can also be checked using the Utility mode "bL" item.
<i>noD</i>	You attempted to recall a scene memory in which no scene had been stored. If you attempt to recall a scene memory in which no scene has been stored, this error message will be displayed for several seconds.
<i>noN</i>	All scene memories contain no data. This error message will be displayed for several seconds if, after all scene memories have been erased in Utility mode, you attempt to store without specifying a scene memory number.
<i>E*</i>	A system error has occurred. (* is the error number) If this error message appears, the M2500 will not operate correctly.

YAMAHA [MIXING CONSOLE]

Date: July/20, 1999

Model : M2500

MIDI Implementation Chart

Version : 1.0

Function...		Transmitted	Recognized	Remarks
Basic Channel	Default Changed	1 - 16 1 - 16	1 - 16 1 - 16	Memorized
Mode	Default Messages Altered	x x *****	OMNI off/OMNI on x x	Memorized
Note Number :	True voice	x *****	x x	
Velocity	Note ON Note OFF	x x	x x	
After Touch	Key's Ch's	x x	x x	
Pitch Bend		x	x	
Control Change	1-70, 105-112	o o o o	o o o o	*1
Prog Change :	True #	o 0 - 127 *****	o 0 - 127 1 - 128	
System Exclusive		o	o	*2
System :	Song Pos	x	x	
Common :	Song Sel	x	x	
:	Tune	x	x	
System :	Clock	x	x	
Real Time	Commands	x	x	
Aux Messages :	Local ON/OFF	x	x	
:	All Notes OFF	x	x	
:	Active Sense	x	o	
:	Reset	x	x	
Notes		*1 : See Control Change chart. *2 : Bulk Dump/Request		

Mode 1 : OMNI ON, POLY Mode 2 : OMNI ON, MONO o : Yes
 Mode 3 : OMNI OFF, POLY Mode 4 : OMNI OFF, MONO x : No

M2500-24/32/40C /48C/56C MIXING CONSOLE

PARTS LIST

■ CONTENTS

OVERALL ASSEMBLY	2
CHASSIS ASSEMBLY	4
MASTERE ASSEMBLY	8
MONO IN ASSEMBLY (MONO16, MONO24, MONO32)	10
METER PANEL ASSEMBLY	12
ELECTRICAL PARTS	14

Notes : DESTINATION ABBREVIATIONS

A : Australian model	M: South African model
B : British model	O : Chinese model
C : Canadian model	Q : South-east Asia model
D : German model	T : Taiwan model
E : European model	U : U.S.A. model
F : French model	V : General export model (110V)
H : North European model	W: General export model (220)
I : Indonesian model	N,X : General export model
J : Japanese model	Y : Export model

■ WARNING

Components having special characteristics are marked  and must be replaced with parts having specification equal to those originally installed.

- The numbers "QTY" show quantities for each unit.
- The parts with "--" in "PART NO." are not available as spare parts.
- This mark "}" in the REMARKS column means these parts are interchangeable.
- The second letter of the shaded (■) part number is O, not zero.
- The second letter of the shaded (■) part number is I, not one.

OVERALL ASSEMBLY

REF NO.	PART NO.	DESCRIPTION		REMARKS	QTY	RANK
	--	OVERALL ASSEMBLY		M2500-24/32/40/48/56		
	--	Overall Assembly		24CH (V442400)		
	--	Overall Assembly		32CH (V442410)		
	--	Overall Assembly		40CH (V442430)		
	--	Overall Assembly		48CH (V442450)		
	--	Overall Assembly		56CH (V442470)		
10	--	Shassis Assembly		24CH (V442480)		
10	--	Shassis Assembly		32CH (V442490)		
10	--	Shassis Assembly		40CH (V442500)		
10	--	Shassis Assembly		48CH (V442510)		
10	--	Shassis Assembly		56CH (V442520)		
20	NX819680	Circuit Board	MSOUT1		3	15
30	VN413300	Bonding Tapping Screw-B	3.0X8 MFZN2BL		60	01
40	NX819720	Circuit Board	MSOUT2			13
50	VN413300	Bonding Tapping Screw-B	3.0X8 MFZN2BL		16	01
* 60	AAX09050	Circuit Board	MASOUT3			
70	VN413300	Bonding Tapping Screw-B	3.0X8 MFZN2BL		16	01
100	--	MASTER Assembly		(V442530)		
110	VN413300	Bonding Tapping Screw-B	3.0X8 MFZN2BL		2	01
120	EP600190	Bind Head Tapping Screw-B	3.0X8 MFZN2BL		17	01
150	--	Mono 16 Assembly		40CH (V442540)		
150	--	MONO 32 Assembly		56CH (V442560)		
160	EP600190	Bind Head Tapping Screw-B	3.0X8 MFZN2BL	40/56CH 21/31		01
170	--	MONO 24 Assembly		24,40,56CH (V442550)		
170	--	MONO 32 Assembly		32CH (V442560)		
170	--	MONO 24 Assembly		48CH (V442550)	2	
180	EP600190	Bind Head Tapping Screw-B	3.0X8 MFZN2BL	26/31/26/52/26		01
200	--	Meter Panel Assembly		24CH (V442570)		
200	--	Meter Panel Assembly		32CH (V442580)		
200	--	Meter Panel Assembly		40CH (V442590)		
200	--	Meter Panel Assembly		48CH (V442600)		
200	--	Meter Panel Assembly		56CH (V442610)		
210	EG340190	Bind Head Tapping Screw-B	4.0X8 MFZN2BL	10/11/13/14/15		01
220	EG340360	Bind Head Screw	4.0X8 MFZN2BL	7/8/9/10/11		01
230	VB923200	Bind Head Screw	4.0X25 MFZN2BL		2	01
300	--	Connector Assembly	METER ASSY	(V431280)		
310	--	Connector Assembly	OUT ASSY	(V431260)		
320	--	Connector Assembly	INBUS ASSY	1/1/2/2/2 (V431290)		
321	--	Connector Assembly	2426&2426 2P 900L	(V541440)		
322	--	Connector Assembly	2426&2426 5P 900L	(V541490)		
330	--	Connector Assembly	STBUS ASSY	(V431310)		
340	--	Connector Assembly	INSERT ASSY	(V431250)		
500	--	Cord Binder	KWS-2 KSS	17/17/19/19/19 (V295160)		
510	VV104600	Cord Holder	CV-100	6/6/9/9/9		01
520	--	Cord Binder	TS-1214 KSS	(V487090)		
		ACCESSORIES				
* 1	V2301600	DC Power Supply Cable				22
* 1a	V3228500	Connector	10 PLS-2410-PMA			
* 1b	V3228400	Connector	10 PLS-2410-PFA			

*: New Parts

RANK: Japan only

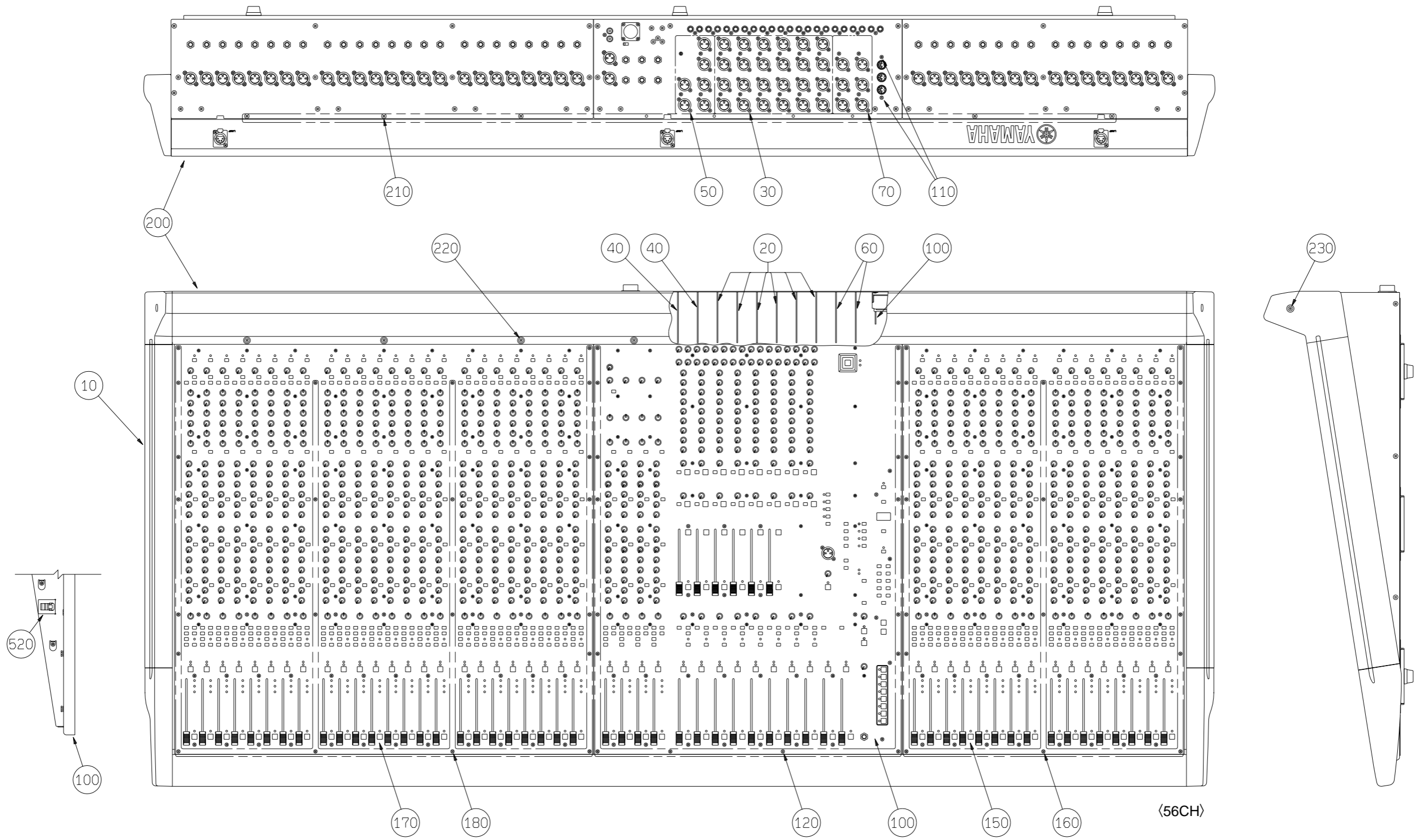

CHASSIS ASSEMBLY

• Left side view

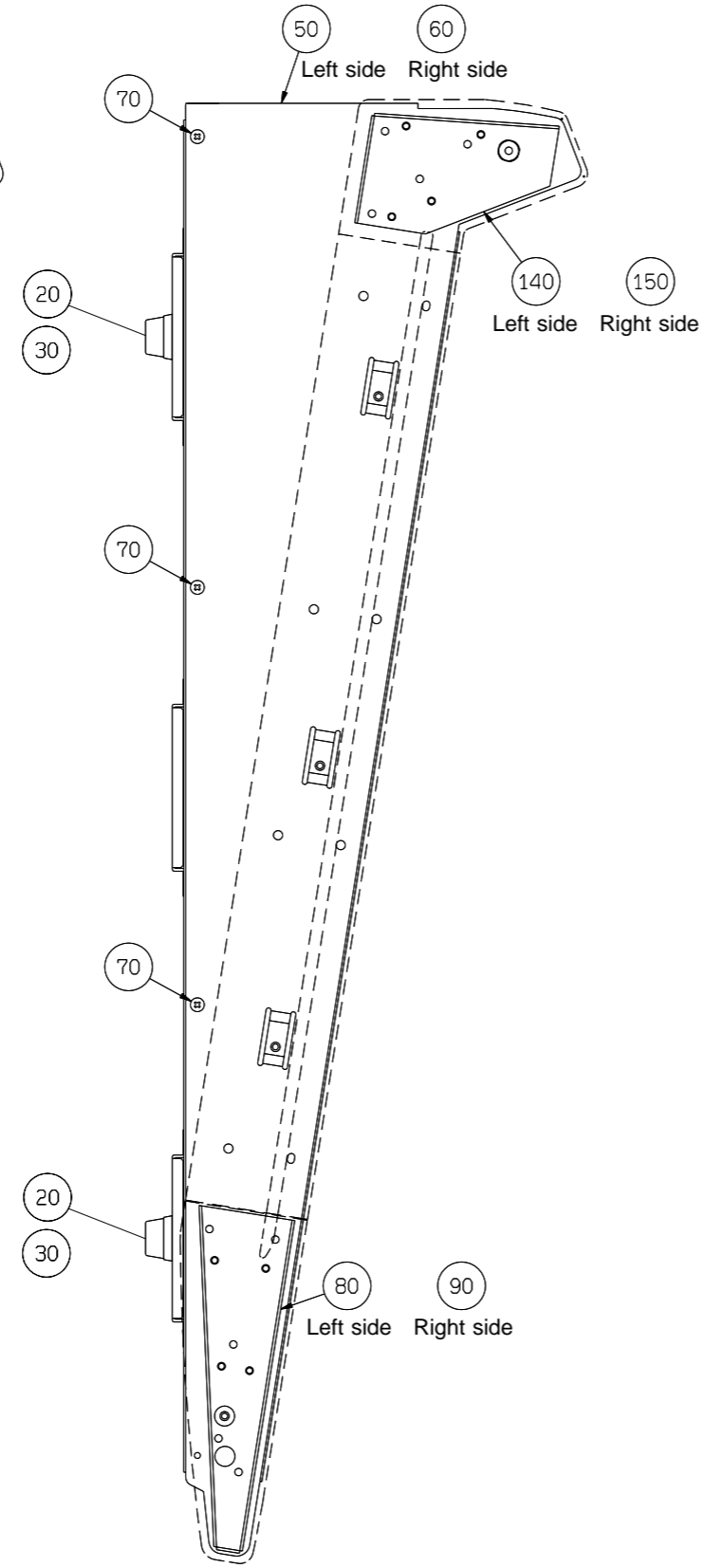
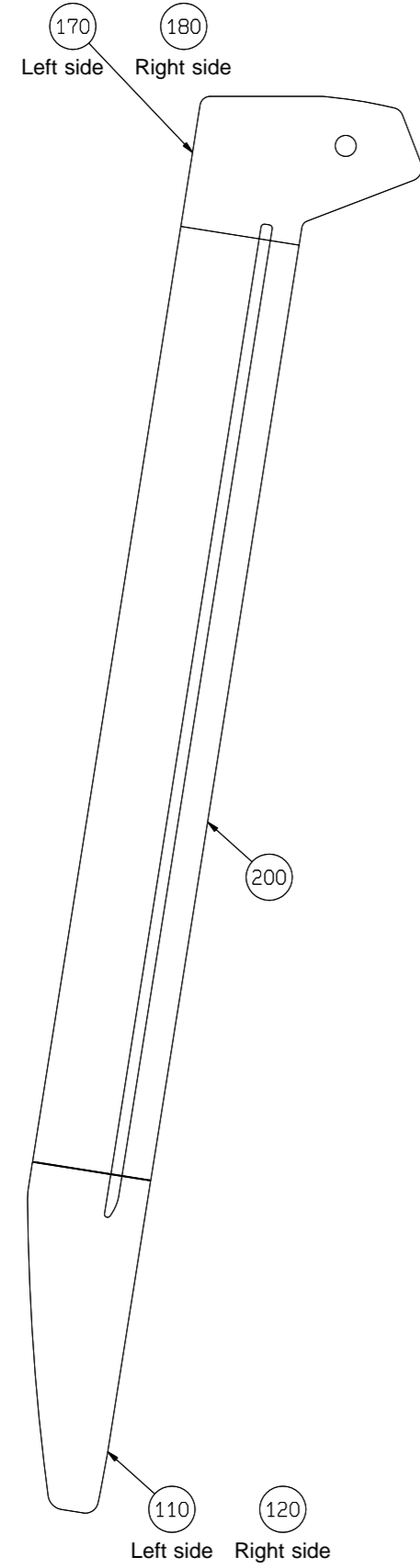

• Right side view

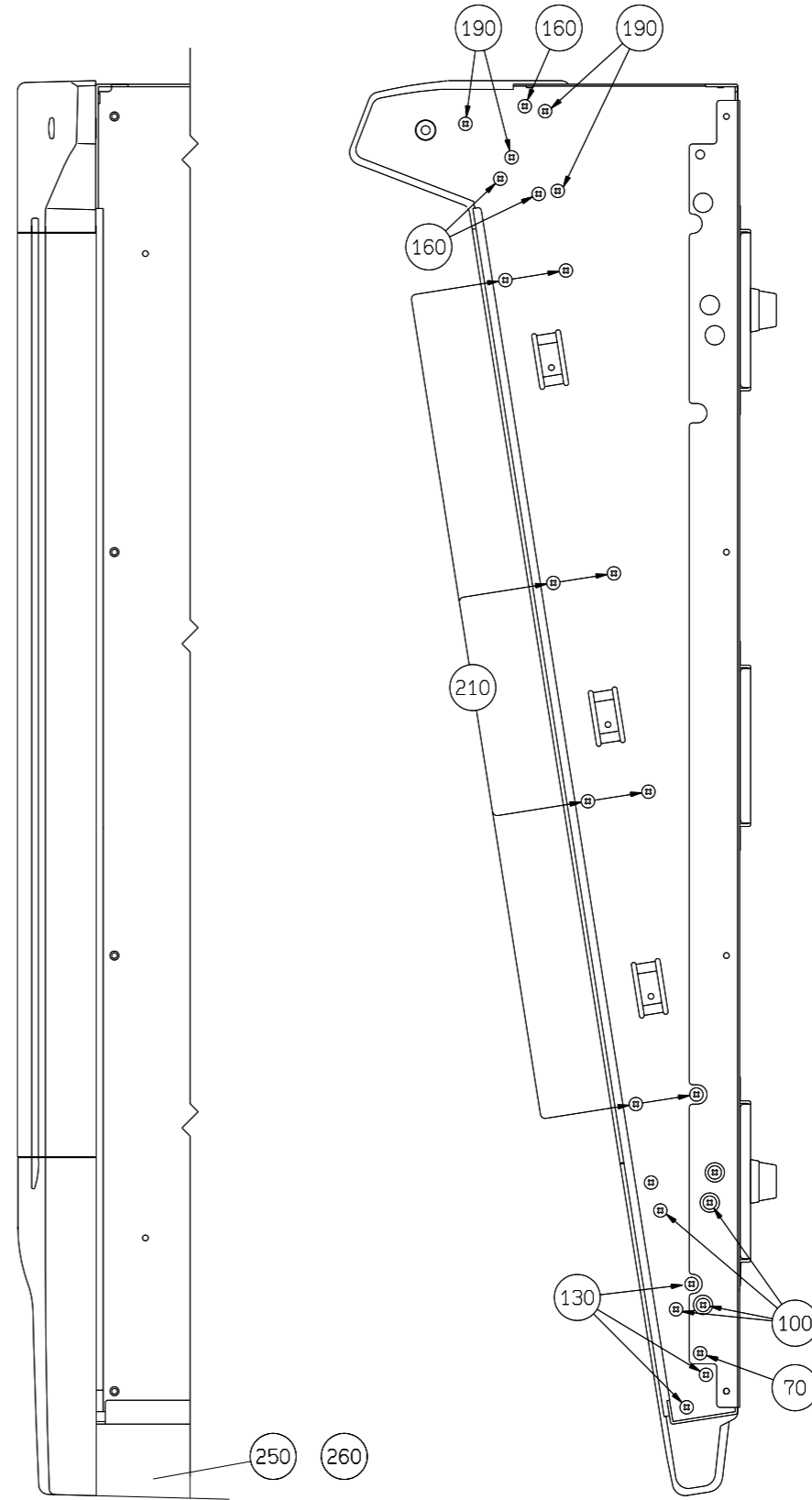

• Top view<56CH>

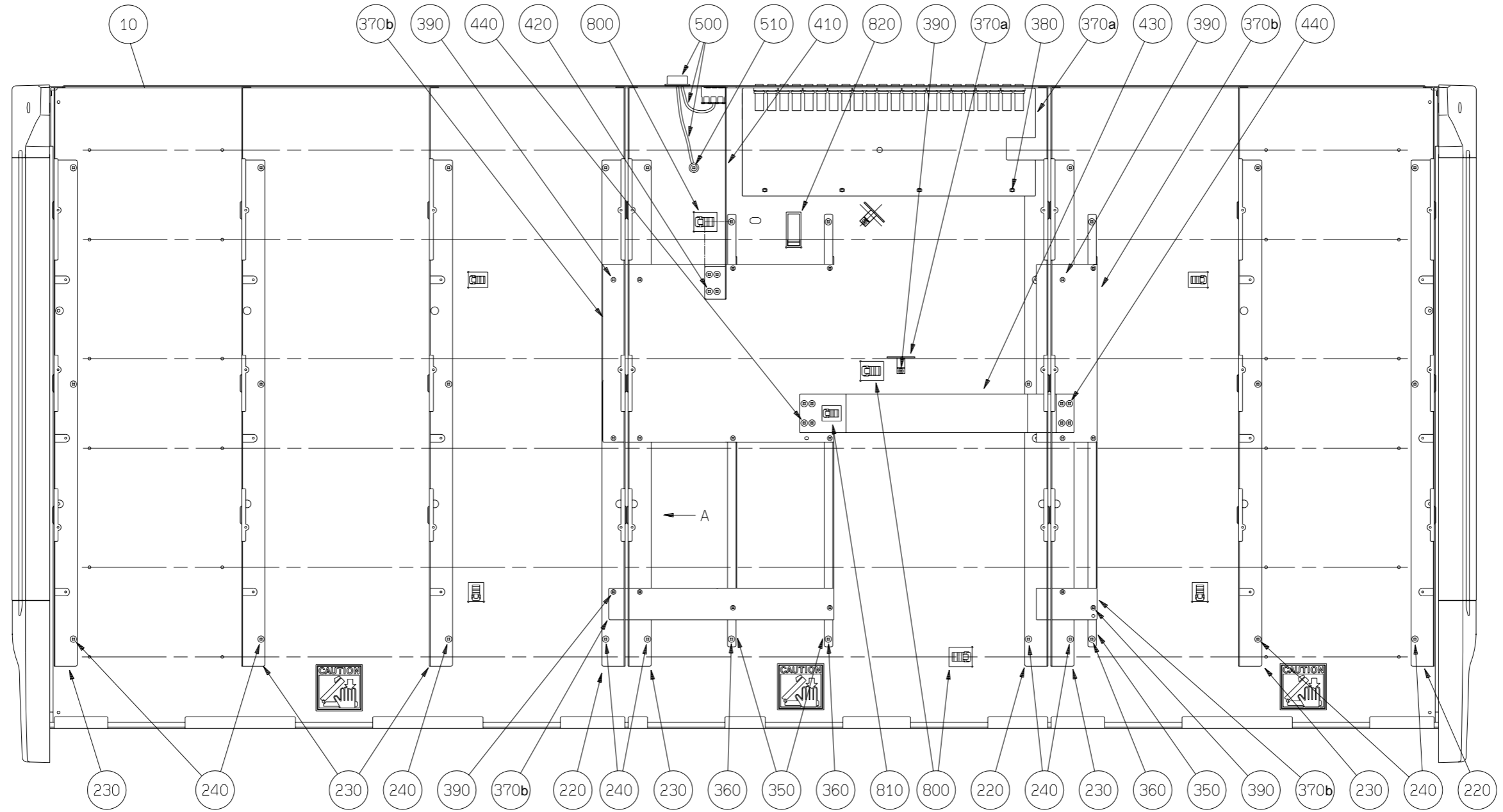

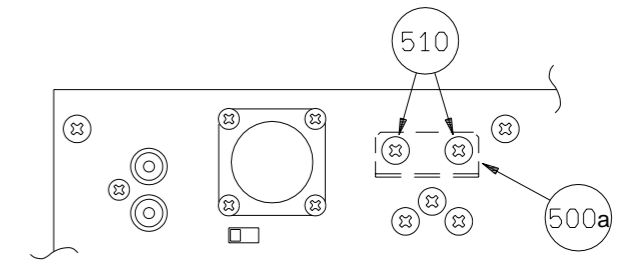
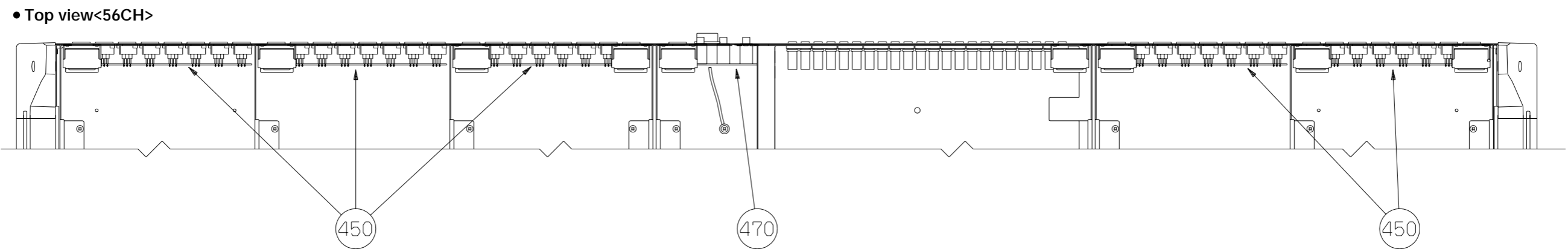
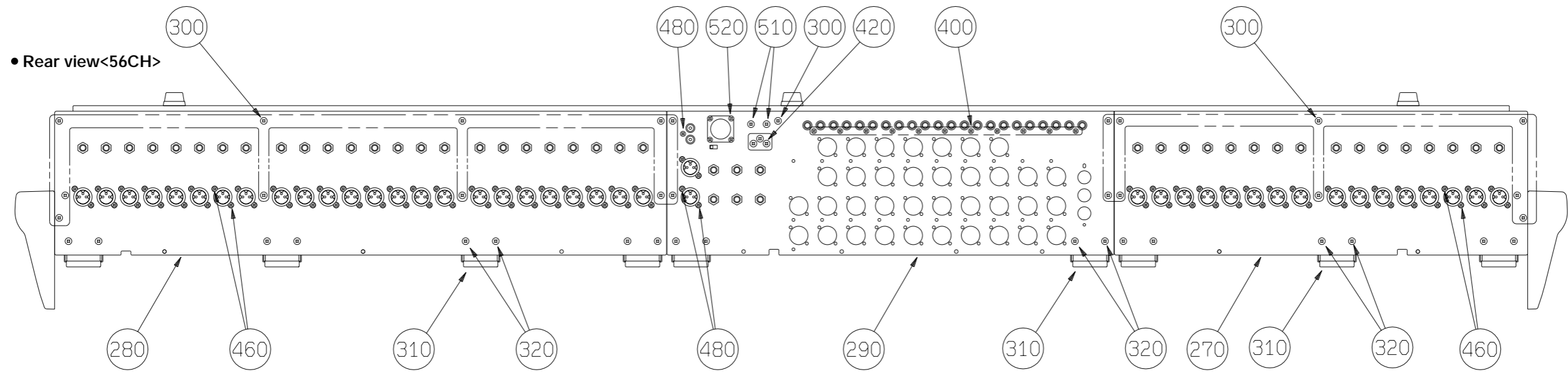
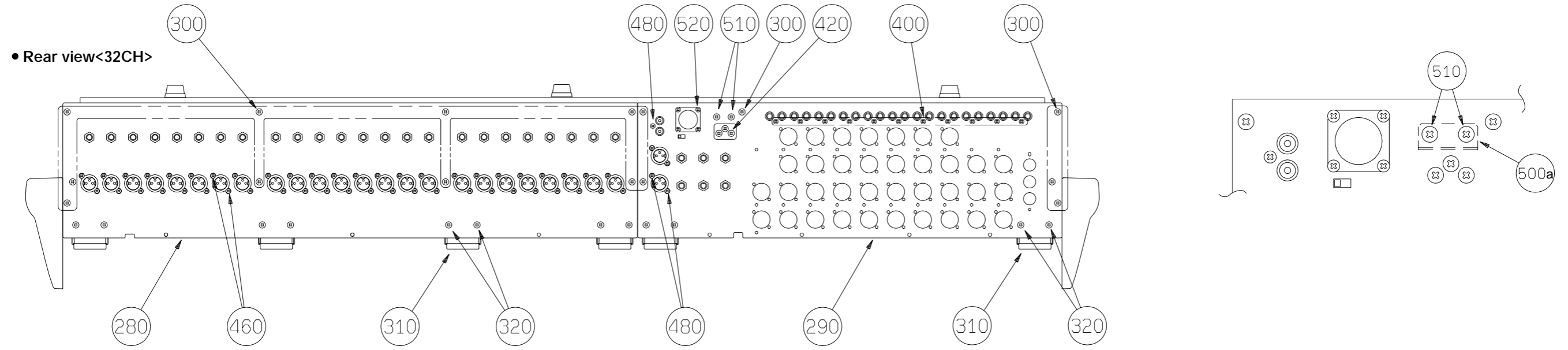

REF NO.	PART NO.	DESCRIPTION	REMARKS	QTY	RANK
	--	SHASSIS ASSEMBLY	M2500-24/32/40/48/56		
	--	Shassis Assembly	24CH (V442480)		
	--	SHassis Assembly	32CH (V442490)		
	--	Shassis Assembly	40CH (V442500)		
	--	Shassis Assembly	48CH (V442510)		
	--	Shassis Assembly	56CH (V442520)		
10	--	Bottom Shassis	24CH (V426250)		
10	--	Bottom Shassis	32CH (V426260)		
10	--	Bottom Shassis	40CH (V426270)		
10	--	Bottom Shassis	48CH (V426280)		
10	--	Bottom Shassis	56CH (V426290)		
20	VV085600	Foot	6/6/6/8	01	
30	VR138400	Bind Head Tapping Screw-B	4.0X12 MFZN2BL	01	
50	--	Side Frame	LEFT (V426300)		
60	--	Side Frame	RIGHT (V426310)		
70	EG340190	Bind Head Tapping Screw-B	4.0X8 MFZN2BL	8	01
80	V2428500	Corner Pad Angle Bracket	FRONT LEFT		05
90	V2428600	Corner Pad Angle Bracket	FRONT RIGHT		05
100	EG340190	Bind Head Tapping Screw-B	4.0X8 MFZN2BL	8	01
110	V2311400	Corner Pad	FRONT LEFT		06
120	V2311500	Corner Pad	FRONT RIGHT		06
130	VS205900	Bind Head Tapping Screw-B	4.0X20 MFZN2BL	10	01
140	V2428700	Corner Pad Angle Bracket	REAR LEFT		05
150	V2428800	Corner Pad Angle Bracket	REAR RIGHT		05
160	EG340190	Bind Head Tapping Screw-B	4.0X8 MFZN2BL	6	01
170	V2311600	Corner Pad	REAR LEFT		05
180	V2311700	Corner Pad	REAR RIGHT		05
190	VS205900	Bind Head Tapping Screw-B	4.0X20 MFZN2BL	8	01
200	V2311200	Side Pad		2	16
210	EG340190	Bind Head Tapping Screw-B	4.0X8 MFZN2BL	16	01
220	--	Center Frame	LEFT (V426320)	3	
230	--	Center Frame	RIGHT (V426330)		
240	EG340190	Bind Head Tapping Screw-B	4.0X8 MFZN2BL		01
250	V4265000	Front Pad	24CH		
250	V4265100	Front Pad	32CH		
250	V4265200	Front Pad	40CH		
250	V4265300	Front Pad	48CH		
250	V4265400	Front Pad	56CH		
260	EG340190	Bind Head Tapping Screw-B	4.0X8 MFZN2BL		01
270	--	Rear Panel	16		
270	--	Rear Panel	24L (V426350)		
270	--	Rear Panel	32 (V426360)		
280	--	Rear Panel	24L (V426380)		
280	--	Rear Panel	24CH, 40CH (V426360)		
280	--	Rear Panel	32 (V426380)		
280	--	Rear Panel	24R1 (V426370)		
280	--	Rear Panel	24R2 (V431180)		
290	--	Rear Panel	CR (V426400)		
300	EG340190	Bind Head Tapping Screw-B	4.0X8 MFZN2BL		01
310	--	Rear Stay	15/17/21/23/25		
320	EG340190	Bind Head Tapping Screw-B	4.0X8 MFZN2BL		01
350	--	PCB Support	6/6/9/10/11 (V446330)		
360	EG340190	Bind Head Tapping Screw-B	4.0X8 MFZN2BL		01
370a	AAX09080	Circuit Board	12/14/18/20/22 (V446370)		
370b	AAX09090	Circuit Board	2/2/3/3/3 (V446370)		
380	VZ336600	PCB Support	6/6/9/9/9	4	01
390	EP600190	Bind Head Tapping Screw-B	3.0X8 MFZN2BL		01
400	VN413300	Bonding Tapping Screw-B	3.0X8 MFZN2BL	11	01
410	V2425100	Earth Bar	LARGE		05
420	EG340360	Bind Head Screw	4.0X8 MFZN2BL	7	01
430	--	Bus Earth Bar	40,48,56CH (V426600)		
440	EG340360	Bind Head Screw	4.0X8 MFZN2BL	8	01
450	AAX08980	Circuit Board	40,48,56CH		
460	VN413300	Bonding Tapping Screw-B	3/4/5/6/7		
470	AAX08990	Circuit Board	48/64/80/96/112		01
480	VN413300	Bonding Tapping Screw-B	STJK	5	01
500	V4290700	Connector Assembly	DC IN ASSY		
500a	V2558000	Connector, DC	10 PLS-2410-RF		11
510	EG340360	Bind Head Screw	4.0X8 MFZN2BL	3	01
520	EP600190	Bind Head Tapping Screw-B	3.0X8 MFZN2BL	4	01
590	--	FFC Cable	BNCDP=1.25K-35-80		
			2/2/6/8/10 (V468110)		

* : New Parts

RANK : Japan only

REF NO.	PART NO.	DESCRIPTION	REMARKS	QTY	RANK
595	--	FFC Cable	SBNCDP1.25-K-35-80		
600	--	FFC Cable	BNCDP=1.25K-14-400		5
610	--	FFC Cable	BNCDP=1.25K-20-300	40,48,56CH	(V436070)
620	--	FFC Cable	BNCDP=1.25K-20-600	2/2/3/3/3	(V436090)
630	--	FFC Cable	BNCDP=1.25K-24-300		(V436120)
640	--	FFC Cable	BNCDP=1.25K-35-300	40,48,56CH	(V436150)
650	--	Connector Assembly	KR-KR 2P 300L		(V468170)
660	--	Connector Assembly	KR-KR 6P 750L		(V541910)
670	--	Connector Assembly	KR-KR 8P 700L		(V468250)
680	--	Connector Assembly	KR-KR 9P 700L		(V468290)
690	--	Connector Assembly	KR-KR 12P 850L		(V468320)
700	--	Connector Assembly	2426&2426 11P 350L	48CH	(V444570)
710	--	Connector Assembly	KR-KR 13P 500L		(V468340)
800	--	Cord Binder	TS-1214 KSS		(V487090)
810	VZ765100	Cord Binder	TS-0708 KSS	2/2/3/3/3	
820	--	Cable Clamp	FCW-30		(V487100)

* : New Parts

RANK : Japan only

MASTER ASSEMBLY

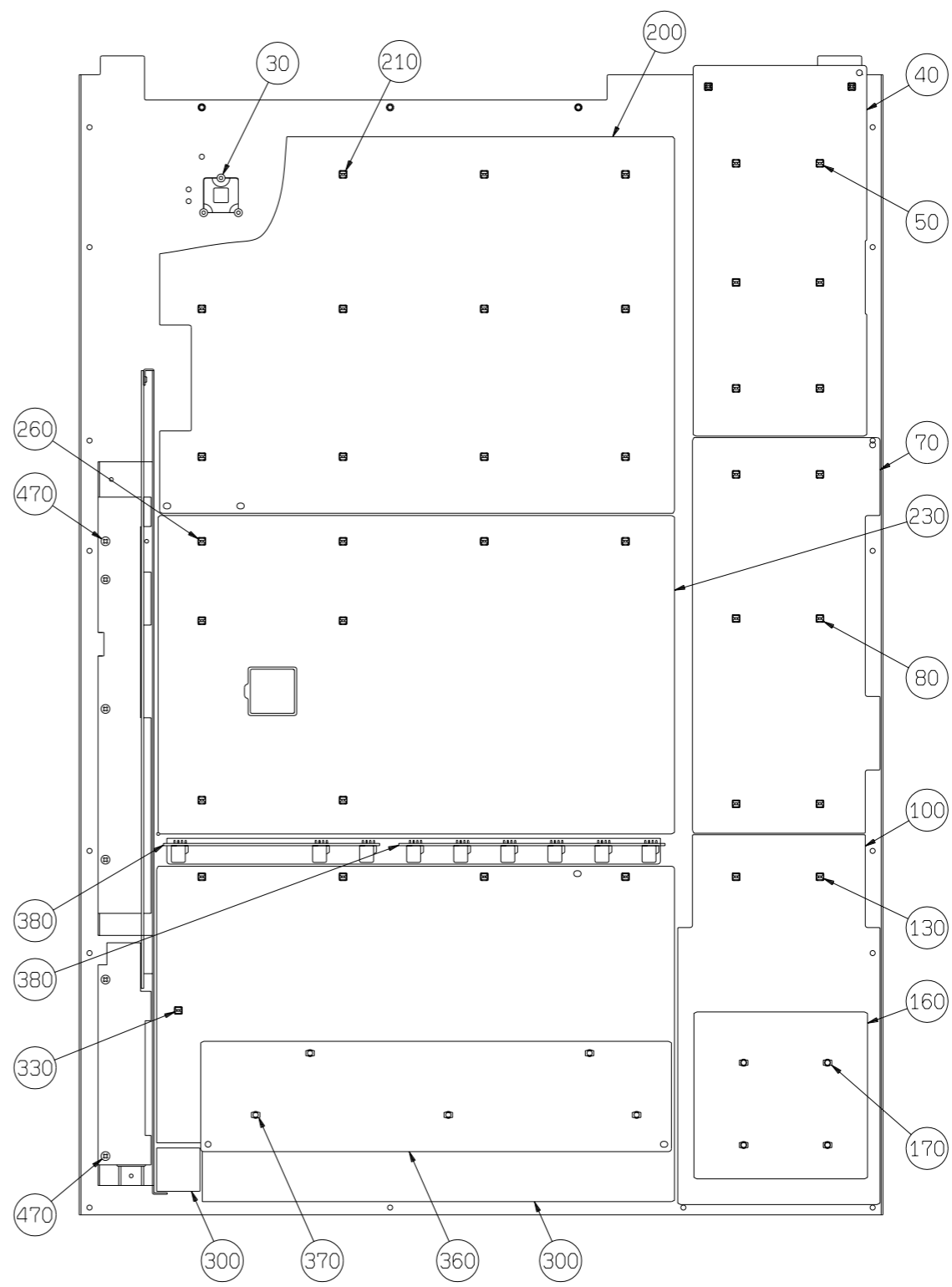
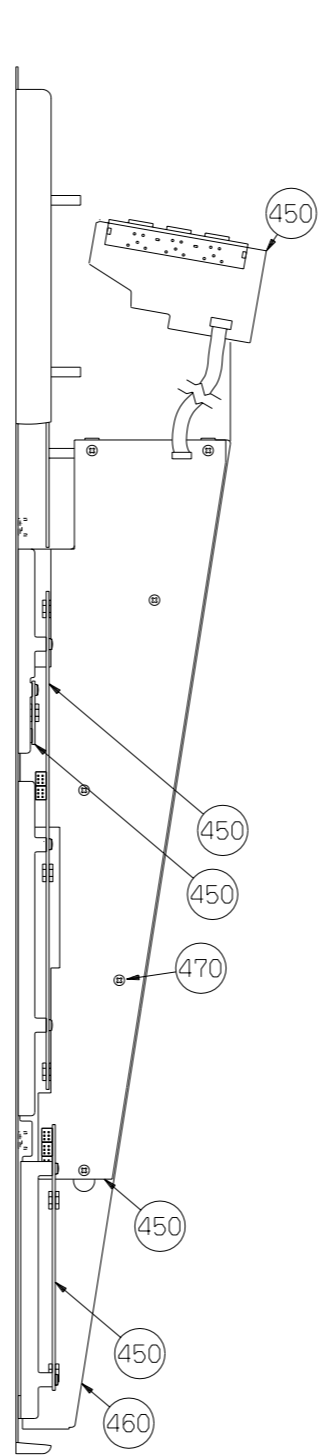
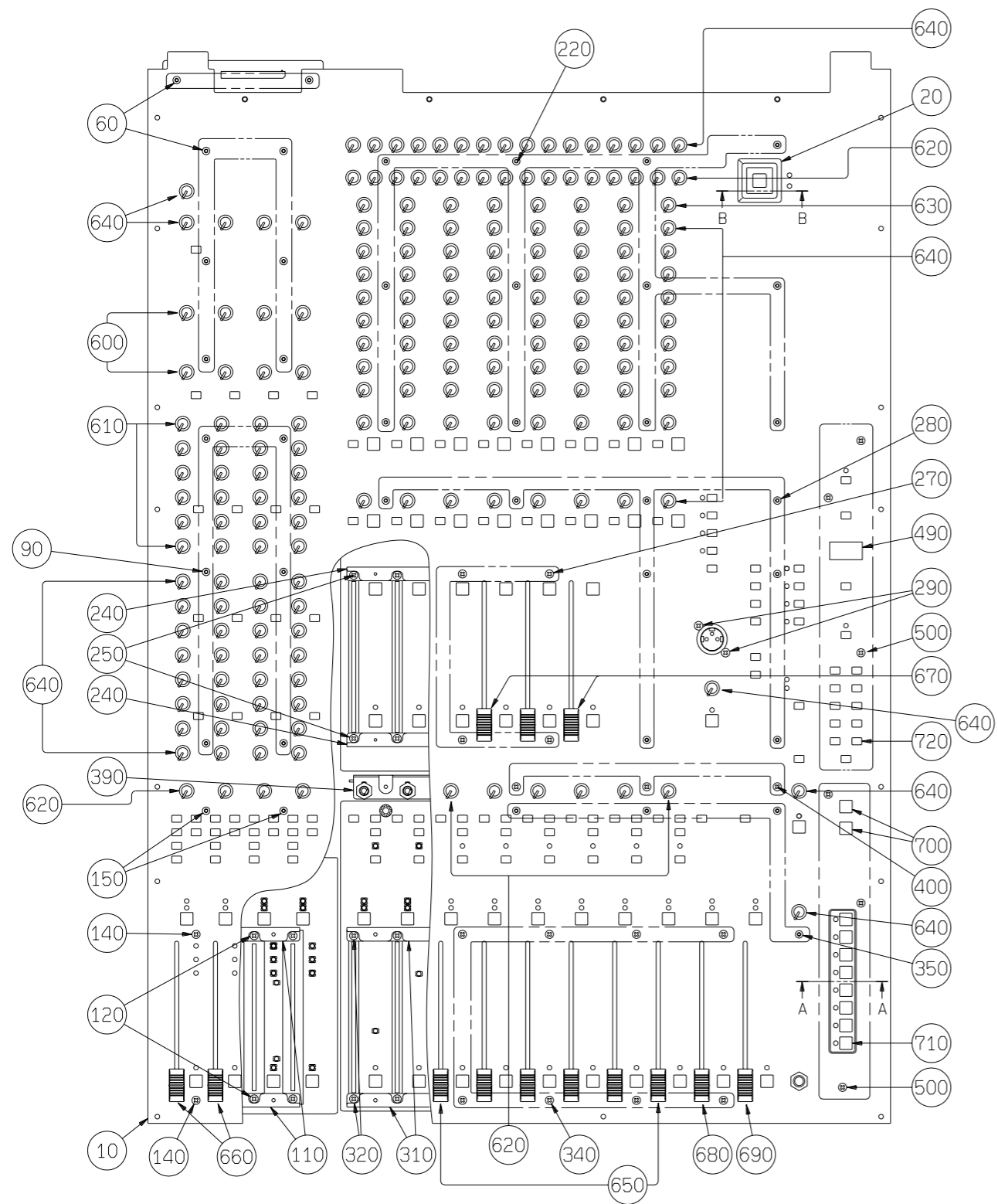

REF NO.	PART NO.	DESCRIPTION	REMARKS	QTY	RANK
		MASTER ASSEMBLY	M2500-24/32/40/48/56		
	--	MASTER Assembly	(V442530)		
* 10	V4262400	Control Panel	MASTER		
* 20	V4266400	Escutcheon			
30	V2256500	Stop Ring	2.4	3	01
* 40	V4313700	Circuit Board	ST1		
50	V3291600	PCB Support	BL	8	01
60	V3289800	Hexagon Socket Tapping Scr	3X25 MFZNBL	8	01
* 70	V4313800	Circuit Board	ST2		
80	V3291600	PCB Support	BL	6	01
90	V3289800	Hexagon Socket Tapping Scr	3X25 MFZNBL	6	01
* 100	V4313900	Circuit Board	ST3		
110	--	Fader Fittings ST		2	
120	VR139400	Bind Head Screw	3.0X4 MFZN2BL	8	01
130	V3291600	PCB Support	BL	2	01
140	EP600190	Bind Head Tapping Screw-B	3.0X8 MFZN2BL	4	01
150	V3289800	Hexagon Socket Tapping Scr	3X25 MFZNBL	2	01
* 160	AA09020	Circuit Board	ST4		
170	VZ336600	PCB Support	CBS-6K	4	01
* 200	V4314100	Circuit Board	MAS1		
210	V3291600	PCB Support	BL	12	01
220	V3289800	Hexagon Socket Tapping Scr	3X25 MFZNBL	12	01
* 230	V4314200	Circuit Board	MAS2		
240	--	Fader Fittings AUX		2	
250	VR139400	Bind Head Screw	3.0X4 MFZN2BL	12	01
260	V3291600	PCB Support	BL	8	01
270	EP600190	Bind Head Tapping Screw-B	3.0X8 MFZN2BL	6	01
280	V3289800	Hexagon Socket Tapping Scr	3X25 MFZNBL	8	01
290	VN413300	Bonding Tapping Screw-B	3.0X8 MFZN2BL	2	01
* 300	V4314400	Circuit Board	MAS3		
310	--	Fader Fittings GRP		2	
320	VR139400	Bind Head Screw	3.0X4 MFZN2BL	20	01
330	V3291600	PCB Support	BL NIFCO	5	01
340	EP600190	Bind Head Tapping Screw-B	3.0X8 MFZN2BL	10	01
350	V3289800	Hexagon Socket Tapping Scr	3X25 MFZNBL	5	01
* 360	AA09040	Circuit Board	MAS4		
370	VZ336600	PCB Support	CBS-6K GIN LIAN	7	01
* 380	AA09030	Circuit Board	MASPAN		
390	--	VR Fitting MA		4	
400	EP600190	Bind Head Tapping Screw-B	3.0X8 MFZN2BL	4	01
450a	VN103500	Lithium Battery	CR2032		03
* 450b	V4314600	Circuit Board	CTRL		
460	--	Shield Plate CTL		12	
470	EP600190	Bind Head Tapping Screw-B	3.0X8 MFZN2BL	12	01
480	--	Window			
490	--	Guide			
500	EP600190	Bind Head Tapping Screw-B	3.0X8 MFZN2BL	6	01
600	VU860200	Knob (small)	MX-GREEN/D-GRAY	8	01
610	VU860300	Knob (small)	MX-BLUE/D-GRAY	24	01
620	VU860400	Knob (small)	RED/D-GRAY	28	01
* 630	V4470000	Knob (small)	YELLOW/D-GRAY	8	
640	VU859700	Knob (small)	N-GRAY/D-GRAY	136	01
			GLP/AUX1-8(PAN1-8), MATRIX1-8(ST-L,R) MATRIX1-8(MONO/C) STEREO1-8(GAIN A,GAIN B, GAIN,AUC7-14), MATRIX1-8(SUS L,SUS R, G1/A7-G8/A14), A7/G1-A14/G8(LEVEL), TB/OSC,MONOTOR LEVEL, PHONES		
650	V2947000	Fader Knob	BLACK/N-GRAY	8	01
660	VV135600	Fader Knob	RED/CD-GRAY	4	01
670	V2946900	Fader Knob	BLACK/MX-BLUE	6	01
680	VU860600	Fader Knob	CL-GRAY/RED		01
* 690	V4468900	Fader Knob	BLACK/YELLOW		
700	VZ968600	Button L	NO.947 CD-GRAY	2	01
710	VZ968700	Button L	NO.946 CL-GRAY	8	01
720	VZ968500	Button S	NO.947 CD-GRAY	15	01
800	--	FFC Cable	BNCDP=1.25K-6-50		
810	--	FFC Cable	BNCDP=1.25K-6-70		

* : New Parts

RANK : Japan only

REF NO.	PART NO.	DESCRIPTION	REMARKS	QTY	RANK
820	--	FFC Cable	BNCDP=1.25K-8-60		
830	--	FFC Cable	BNCDP=1.25K-6-100		5
840	--	FFC Cable	BNCDP=1.25K-14-60		8
850	--	FFC Cable	BNCDP=1.25K-14-150		2
870	--	Connector Assembly	KR-KR 2P 80L		2
880	--	Connector Assembly	KR-KR 4P 60L		
890	--	Connector Assembly	KR-KR 5P 250L		
900	--	Connector Assembly	KR-KR 9P 180L		
910	--	Connector Assembly	KR-KR 11P 250L		
920	--	Connector Assembly	2426&2426 10P 60L		

* : New Parts

RANK : Japan only

■ MONO IN ASSEMBLY

(MONO16, MONO24 & MONO32)

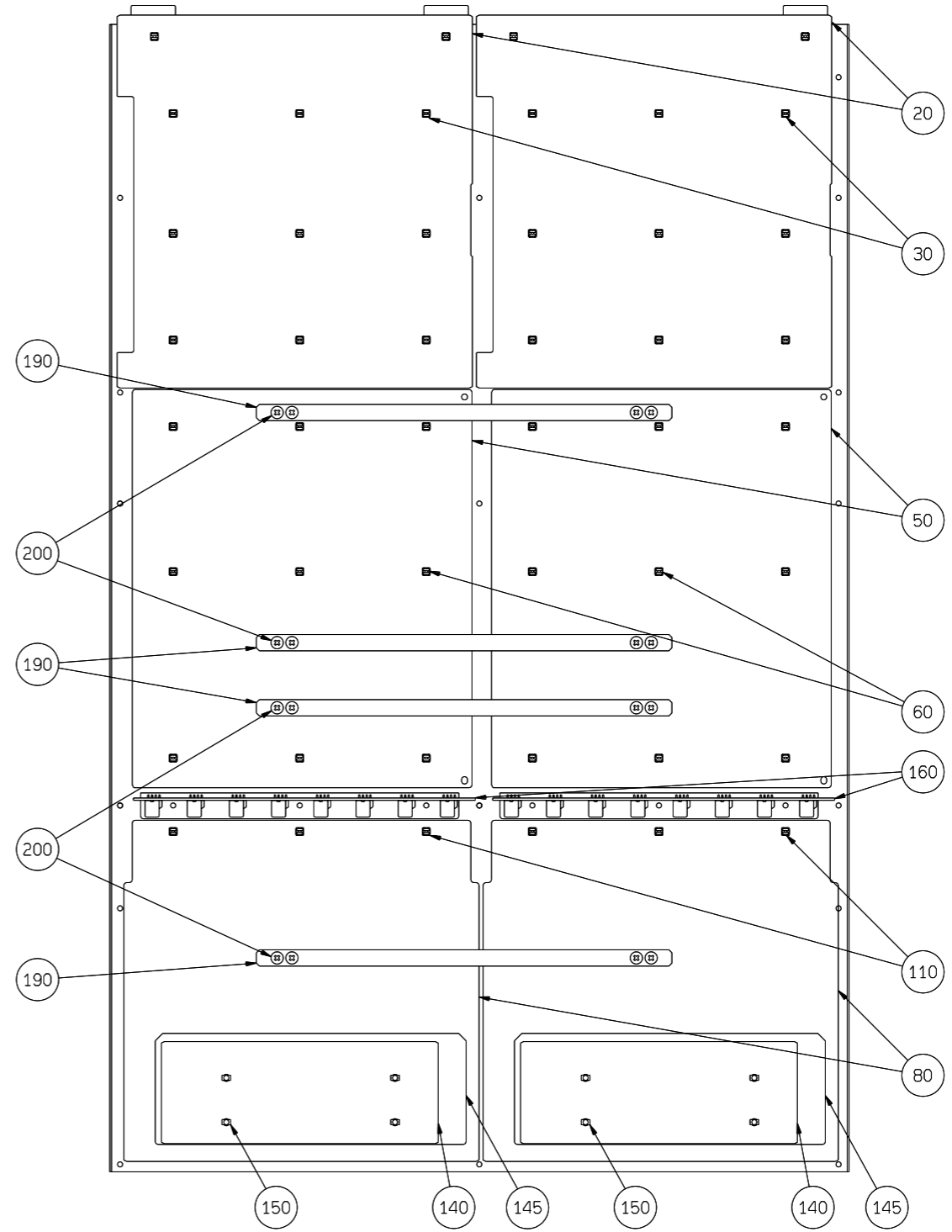
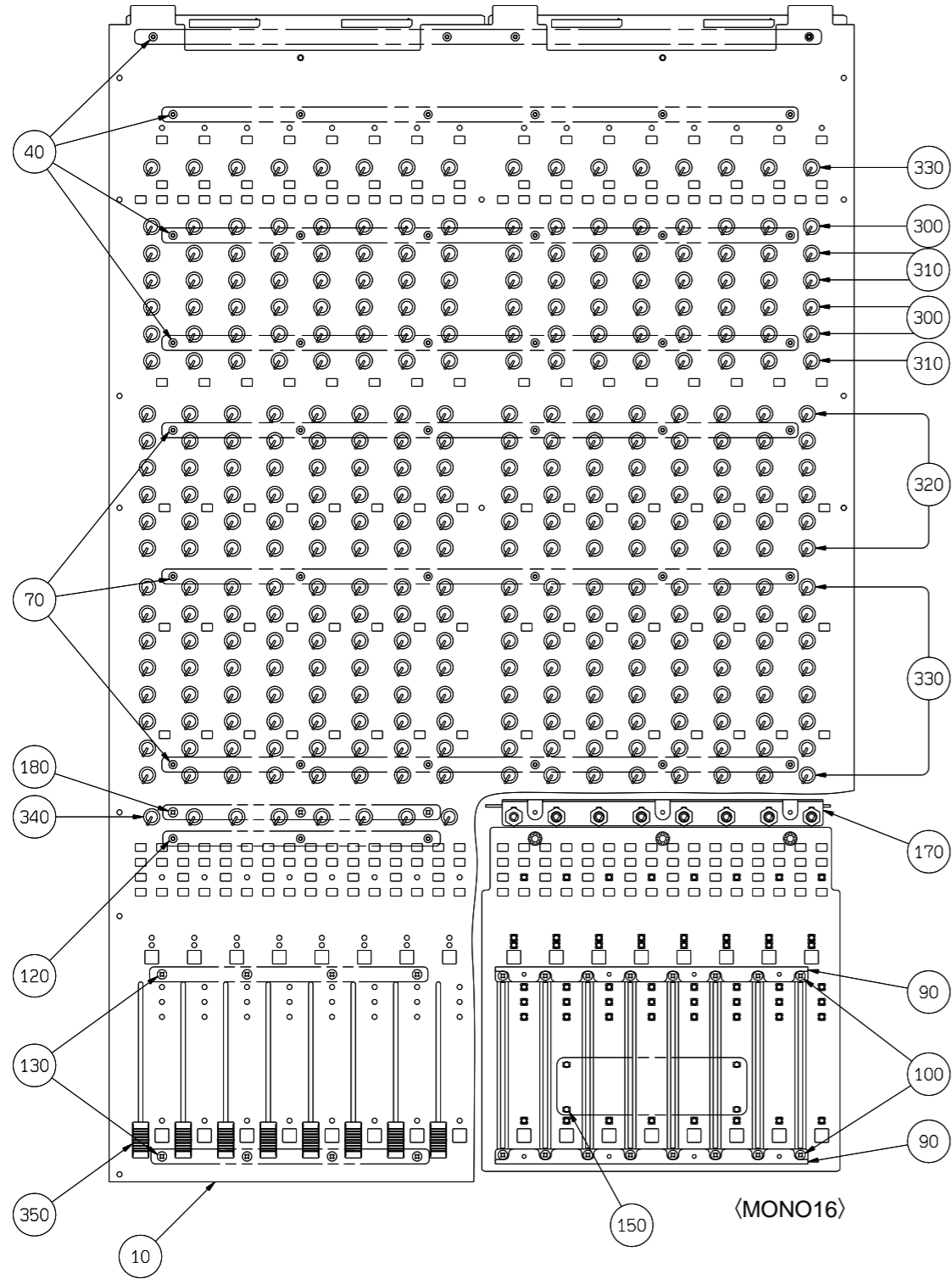

REF NO.	PART NO.	DESCRIPTION	REMARKS	QTY	RANK
	--	MONO 16 ASSEMBLY	M2500-40		
	--	MONO 16 Assembly	(V442540)		
* 10	V4261700	Control Panel	16CH		
* 20	V4313200	Circuit Board	IN1	2	
30	V3291600	PCB Support	BL	22	01
40	V3289800	Hexagon Socket Tapping Scr	3X25 MFZNBL	22	01
* 50	V4313300	Circuit Board	IN2	2	
60	V3291600	PCB Support	BL	18	01
70	V3289800	Hexagon Socket Tapping Scr	3X25 MFZNBL	18	01
* 80	V4313500	Circuit Board	IN3	2	
90	--	Fader Fittings MO			(V426430)
100	VR139400	Bind Head Screw	3.0X4 MFZN2BL	4	01
110	V3291600	PCB Support	BL	6	01
120	V3289800	Hexagon Socket Tapping Scr	3X25 MFZNBL	6	01
130	EP600190	Bind Head Tapping Screw-B	3.0X8 MFZN2BL	16	01
* 140	AAX09010	Circuit Board	IN4		
145	--	Shield Plate S			(V473810)
150	--	PCB Support	CS-0305 KSS		(V487810)
* 160	AAX09000	Circuit Board	INPAN		
170	--	VR Fittings MO			(V426410)
180	EP600190	Bind Head Tapping Screw-B	3.0X8 MFZN2BL	6	01
190	--	Earth Bar 16			(V426610)
200	EG340360	Bind Head Screw	4.0X8 MFZN2BL	16	01
300	VU860200	Knob (small)	MX-GREEN/D-GRAY	48	01
310	VZ968800	Knob (small)	556C-LGREEN/D-GRAY	48	01
320	VU860300	Knob (small)	MX-BLUE/D-GRAY	96	01
330	VU859700	Knob (small)	N-GRAY/D-GRAY	144	01
340	VU860400	Knob (small)	RED/D-GRAY	16	01
350	VU860500	Fader Knob	BLACK/CL-GRAY	16	01
400	--	FFC Cable	BNCDP=1.25K-6-50		(V435960)
410	--	FFC Cable	BNCDP=1.25K-8-60		(V435990)
420	--	FFC Cable	BNCDP=1.25K-14-150		(V436030)
430	--	FFC Cable	BNCDP=1.25K-24-50		(V436100)
450	--	FFC Cable	BNCDP=1.25K-20-90		(V436060)
460	--	Connector Assembly	KR-KR 3P 40L		(V468180)
470	--	Connector Assembly	KR-KR 5P 40L		(V468200)
490	--	Connector Assembly	KR-KR 7P 40L		(V362110)
500	--	Connector Assembly	KR-KR 10P 40L		(V468300)
510	--	Connector Assembly	KR-KR 13P 40L		(V468330)
520	--	Connector Assembly	KR-KR 4P 120L		(V487960)
530	--	FFC Cable	BNCDP=1.25K-6-100		(V468130)
540	--	Connector Assembly	2426&2426 2P 80L		
	--	MONO 24 ASSEMBLY	M2500-24/40/48/56		
	--	MONO 24 Assembly	(V442550)		
* 10	V4262200	Control Panel	24CH		
* 20	V4313200	Circuit Board	IN1	3	
30	V3291600	PCB Support	BL	33	01
40	V3289800	Hexagon Socket Tapping Scr	3X25 MFZNBL	33	01
* 50	V4313300	Circuit Board	IN2	3	
60	V3291600	PCB Support	BL	27	01
70	V3289800	Hexagon Socket Tapping Scr	3X25 MFZNBL	27	01
* 80	V4313500	Circuit board	IN3	3	
90	--	Fader Fittings MO			(V426430)
100	VR139400	Bind Head Screw	3.0X4 MFZN2BL	6	01
110	V3291600	PCB Support	BL	9	01
120	V3289800	Hexagon Socket Tapping Scr	3X25 MFZNBL	9	01
130	EP600190	Bind Head Tapping Screw-B	3.0X8 MFZN2BL	24	01
* 140	AAX09010	Circuit Board	IN4	3	
145	--	Shield Plate S			(V473810)
150	--	PCB Support	CS-0305 KSS		(V487810)
* 160	AAX09000	Circuit Board	INPAN	3	
170	--	VR Fittings MO			(V426410)
180	EP600190	Bind Head Tapping Screw-B	3.0X8 MFZN2BL	9	01
190	--	Earth Bar 24			(V426620)
200	EG340360	Bind Head Screw	4.0X8 MFZN2BL	4	01
300	VU860200	Knob (small)	MX-GREEN/D-GRAY	72	01
310	VZ968800	Knob (small)	556C-LGREEN/D-GRAY	72	01
320	VU860300	Knob (small)	MX-BLUE/D-GRAY	144	01
330	VU859700	Knob (small)	N-GRAY/D-GRAY	216	01

* : New Parts

RANK : Japan only

REF NO.	PART NO.	DESCRIPTION	REMARKS	QTY	RANK
340	VU860400	Knob (small)	RED/D-GRAY		
350	VU860500	Fader Knob	BLACK/CL-GRAY		
400	--	FFC Cable	BNCDP=1.25K-6-50		(V435960)
410	--	FFC Cable	BNCDP=1.25K-8-60		(V435990)
420	--	FFC Cable	BNCDP=1.25K-14-150		(V436030)
430	--	FFC Cable	BNCDP=1.25K-24-50		(V436100)
450	--	FFC Cable	BNCDP=1.25K-20-90		(V436060)
460	--	Connector Assembly	KR-KR 3P 40L		(V468180)
470	--	Connector Assembly	KR-KR 5P 40L		(V468200)
490	--	Connector Assembly	KR-KR 7P 40L		(V362110)
500	--	Connector Assembly	KR-KR 10P 40L		(V468300)
510	--	Connector Assembly	KR-KR 13P 40L		(V468330)
520	--	Connector Assembly	KR-KR 4P 120L		(V487960)
530	--	FFC Cable	BNCDP=1.25K-6-100		(V468130)
540	--	Connector Assembly	2426&2426 2P 80L		
	--	MONO 32 ASSEMBLY	M2500-32/56		
	--	MONO 32 Assembly	(V442560)		
* 10	V4262300	Control Assembly	32CH		
* 20	V4313200	Circuit Board	IN1	4	
30	V3291600	PCB Support	BL	44	01
40	V3289800	Hexagon Socket Tapping Scr	3X25 MFZNBL	44	01
* 50	V4313300	Circuit Board	IN2	4	
60	V3291600	PCB Support	BL	36	01
70	V3289800	Hexagon Socket Tapping Scr	3X25 MFZNBL	36	01
* 80	V4313500	Circuit Board	IN3	4	
90	--	Fader Fittings MO			(V426430)
100	VR139400	Bind Head Screw	3.0X4 MFZN2BL	64	01
110	V3291600	PCB Support	BL	12	01
120	V3289800	Hexagon Socket Tapping Scr	3X25 MFZNBL	12	01
130	EP600190	Bind Head Tapping Screw-B	3.0X8 MFZN2BL	32	01
* 140	AAX09010	Circuit Board	IN4	2	
145	--	Shield Plate S			(V473810)
150	--	PCB Support	CS-0305 KSS		(V487810)
* 160	AAX09000	Circuit Board	INPAN	2	
170	--	VR Fittings MO			(V426410)
180	EP600190	Bind Head Tapping Screw-B	3.0X8 MFZN2BL	12	01
190	--	Earth Bar 32			(V426630)
200	EG340360	Bind Head Screw	4.0X8 MFZN2BL	32	01
300	VU860200	Knob (small)	MX-GREEN/D-GRAY	96	01
310	VZ968800	Knob (small)	556C-LGREEN/D-GRAY	96	01
320	VU860300	Knob (small)	MX-BLUE/D-GRAY	192	01
330	VU859700	Knob (small)	N-GRAY/D-GRAY	288	01
340	VU860400	Knob (small)	RED/D-GRAY	32	01
350	VU860500	Fader Knob	BLACK/CL-GRAY	32	01
400	--	FFC Cable	BNCDP=1.25K-6-50		(V435960)
410	--	FFC Cable	BNCDP=1.25K-8-60		(V435990)
420	--	FFC Cable	BNCDP=1.25K-14-150		(V436030)
430	--	FFC Cable	BNCDP=1.25K-24-50		(V436100)
450	--	FFC Cable	BNCDP=1.25K-20-90		(V436060)
460	--	Connector Assembly	KR-KR 3P 40L		(V468180)
470	--	Connector Assembly	KR-KR 5P 40L		(V468200)
490	--	Connector Assembly	KR-KR 7P 40L		(V362110)
500	--	Connector Assembly	KR-KR 10P 40L		(V468300)
510	--	Connector Assembly	KR-KR 13P 40L		(V468330)
520	--	Connector Assembly	KR-KR 4P 120L		(V487960)
530	--	FFC Cable	BNCDP=1.25K-6-100		(V468130)

* : New Parts

RANK : Japan only

METER PANEL ASSEMBLY

• Front view

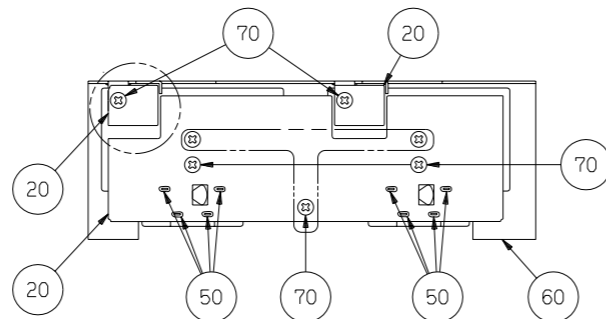
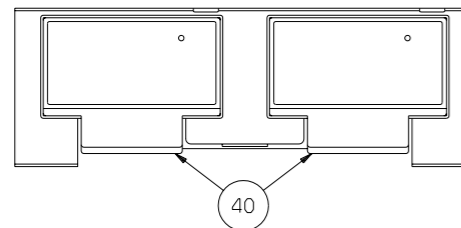

1 / 7 - 8 / 14 (4 pcs.)

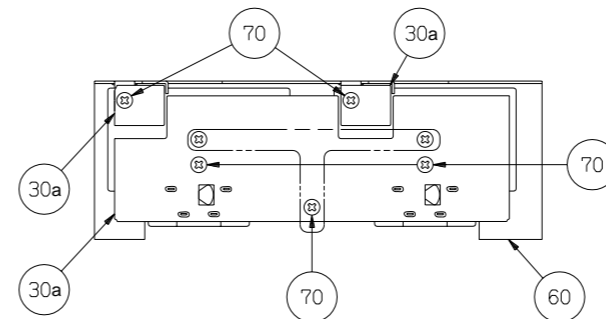

STEREO L & MONO (1 pcs.)

• Front view

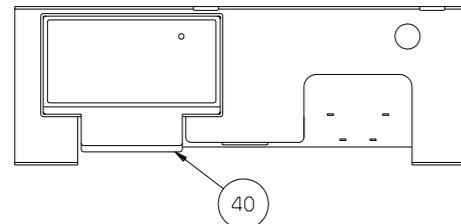

• Rear view

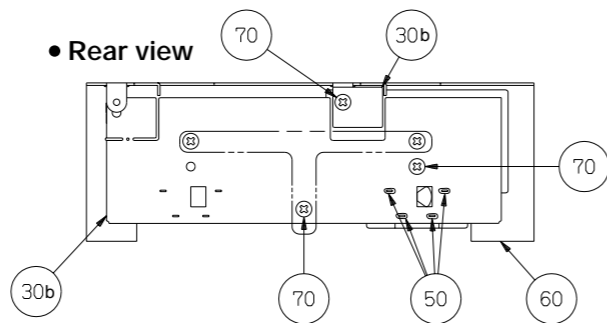

STEREO R (1 pcs.)

• Right side view

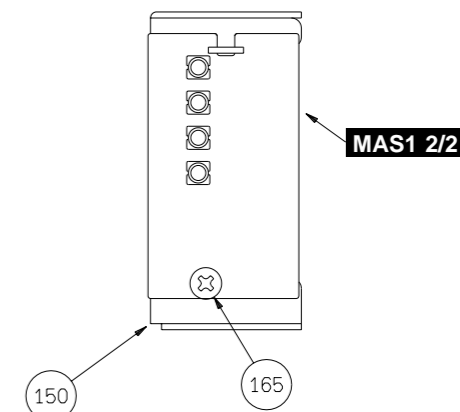
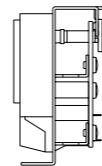

Power supply LED

• Front view

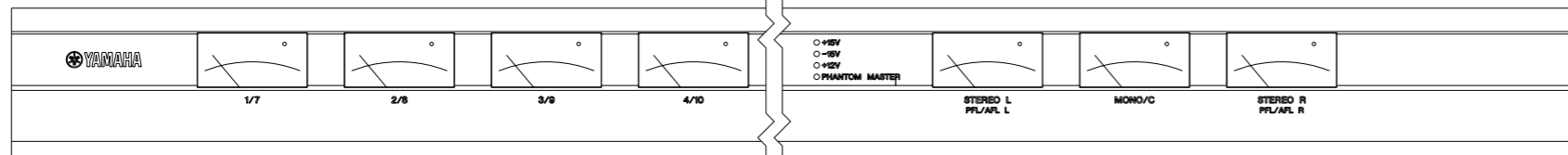

• Bottom view

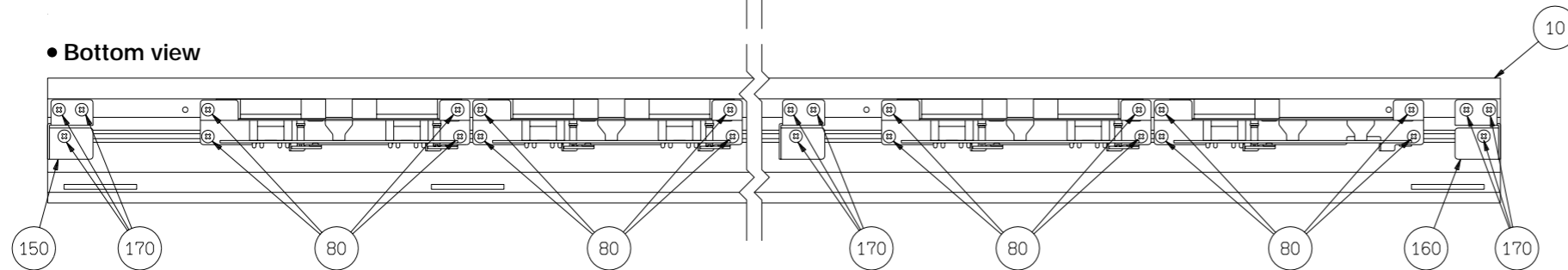

• Rear view

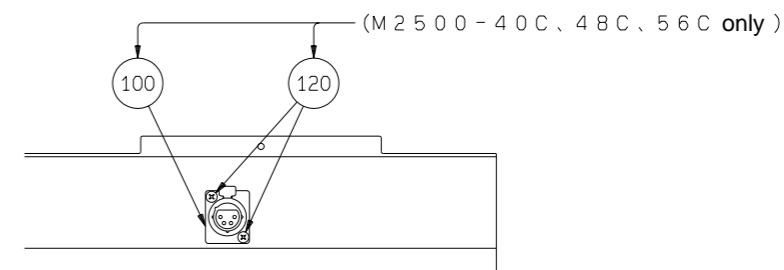
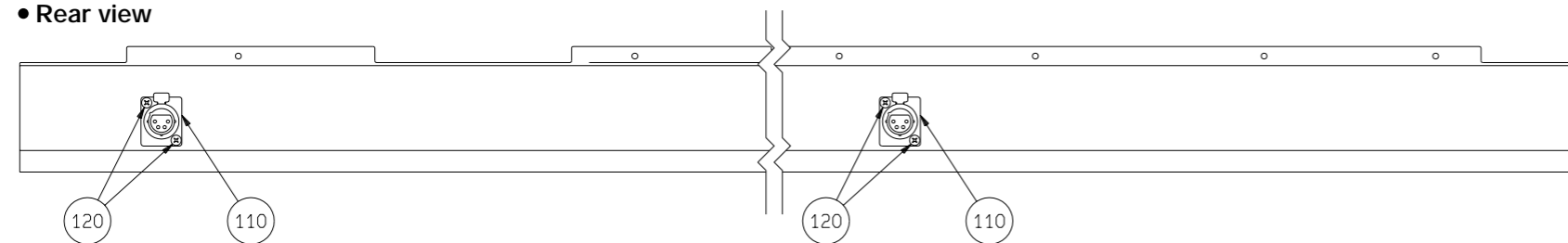

REF NO.	PART NO.	DESCRIPTION		REMARKS	QTY	RANK
	--	METER PANEL ASSEMBLY				
	--	Meter Panel Assembly		24CH (V442570)		
	--	Meter Panel Assembly		32CH (V442580)		
	--	Meter Panel Assembly		40CH (V442590)		
	--	Meter Panel Assembly		48CH (V442600)		
	--	Meter Panel Assembly		56CH (V442610)		
* 10	V4265500	Meter Panel		24CH		
* 10	V4265600	Meter Panel		32CH		
* 10	V4265700	Meter Panel		40CH		
* 10	V4265800	Meter Panel		48CH		
* 10	V4265900	Meter Panel		56CH		
* 20	AAX09060	Circuit Board	METER1		2	
* 30a	AAX09100	Circuit Board	METER2 1/2 1,2,3/3			
* 30b	AAX09070	Circuit Board	METER2 2/2 1,2/3			
* 40	V3855100	Analog Meter	VU TN-72		11	
60	--	Meter Bracket		(V426470)	6	
70	EP600190	Bind Head Tapping Screw-B	3.0X8 MFZN2BL		29	01
75	EP600190	Bind Head Tapping Screw-P	3.0X8 MFZN2BL		11	01
80	EG340190	Bind Head Tapping Screw-B	4.0X8 MFZN2BL		26	01
100	V2426000	Connector Assembly	LAMP L ASSY			09
100a	FG644100	Ceramic Capacitor-F	0.01 50V Z			01
100b	VS647300	XLM Connector	HA16PRK-4S			07
110	V2426100	Connector Assembly	LAMP S ASSY		2	09
110a	FG644100	Ceramic Capacitor-F	0.01 50V Z			01
110b	VS647300	XLM Connector	HA16PRK-4S			07
120	EE620190	Pan Head Screw	2.6X8 MFNI33	4/4/6/6/6	4	01
150	--	Meter Panel Fittings L		(V426480)	2	
160	--	Meter Panel Fittings R		(V426490)		
165	EP600190	Bind Head Tapping Screw-B	3.0X8 MFZN2BL			01
170	EG340190	Bind Head Tapping Screw-B	4.0X8 MFZN2BL		9	01
200	--	Connector Assembly	KR-KR 9P 60L	(V468260)	4	
210	--	Connector Assembly	KR-KR 9P 140L	(V468280)		

*: New Parts

RANK: Japan only

ELECTRICAL PARTS

REF NO.	PART NO.	DESCRIPTION	REMARKS	QTY	RANK
		ELECTRICAL PARTS	M2500-24/32/40/48/56		
*	V4314600	Circuit board	CTRL (XW219B0)		
*	V4313200	Circuit Board	IN1 (XW201B0)		
*	V4313300	Circuit Board	IN2 (XW202B0)		
*	V4313500	Circuit Board	IN3 (XW203B0)		
*	AAX09010	Circuit Board	IN4 (XW204B0)		
*	AAX08980	Circuit Board	INJK (XW206B0)		
*	AAX09000	Circuit Board	INPAN (XW205B0)		
*	AAX09080	Circuit Board	ISRT 1,6/6 (XW217B0)		
*	AAX09090	Circuit Board	ISRT 2,3,4,5/6 (XW217B0)		
*	V4314100	Circuit Board	MAS1 (XW212B0)		
*	V4314200	Circuit Board	MAS2 (XW213B0)		
*	V4314400	Circuit Board	MAS3 (XW21BA0)		
*	AAX09040	Circuit Board	MAS4 (XW215B0)		
*	AAX09030	Circuit Board	MASPAN (XW216B0)		
*	AAX09060	Circuit Board	METER1 (XW218B0)		
*	AAX09070	Circuit Board	METER2 2/2 1,2/3 (XW600B0)		
*	AAX09100	Circuit Board	METER2 1/2 1,2,3/3 (XW600B0)		
*	NX819680	Circuit Board	MSOUT1 (XV388D0)		
*	NX819720	Circuit Board	MSOUT2 (XV388D0)		
*	AAX09050	Circuit Board	MASOUT3 (XW601B0)		
*	V4313700	Circuit Board	ST1 (XW207B0)		
*	V4313800	Circuit Board	ST2 (XW208B0)		
*	V4313900	Circuit Board	ST3 (XW209B0)		
*	AAX09020	Circuit Board	ST4 (XW210B0)		
*	AAX08990	Circuit Board	STJK (XW211B0)		
*	V4314600	Circuit board	CTRL (XW219B0)		
	CB056250	LED Spacer			01
	VL184700	IC Socket	DICF-28CS-E		02
	VN103600	Battery Holder	CR2032		03
CN001	VN304300	Connector	5532-NA 6P TE		01
-007	VN304300	Connector	5532-NA 6P TE		01
CN008	VB390000	Connector Base Post	PH- 4P TE		01
CN101	VN304000	Connector	5533-NAPB 6P SE		01
-107	VN304000	Connector	5533-NAPB 6P SE		01
CN108	V2504100	Connector Assembly	SAN&PH 4P 350L		05
CN121	VB390300	Connector Base Post	PH- 7P TE		01
CN122	VB390600	Connector Base Post	PH-10P TE		01
CN123	VB390700	Connector Base Post	PH-11P TE		01
CN124	VB390100	Connector Base Post	PH- 5P TE		01
CN224	VB390800	Connector Base Post	PH-12P TE		01
CN225	VB390400	Connector Base Post	PH- 8P TE		01
CN226	VB390500	Connector Base Post	PH- 9P TE		03
CN230	VB390200	Connector Base Post	PH- 6P TE		01
D101	VT332900	Diode	1SS355 TE-17		01
D201	VT332900	Diode	1SS355 TE-17		01
-225	VT332900	Diode	1SS355 TE-17		01
D301	VT332900	Diode	1SS355 TE-17		01
EM101	FZ006970	LC Filter	LS MT Y223NB		02
EM102	FZ006970	LC Filter	LS MT Y223NB		02
*	IC101	XW642C00	IC	EPROM 512K	
	IC102	XV411A00	IC	SRAM 256K	07
	IC102	XW433A00	IC	SRAM 256K	
	IC103	XK278A00	IC	CPU (MAIN)	09
	IC104	XM047A00	IC	GATE ARRAY	07
	IC105	XQ962D00	IC	DSP3	20
	IC106	XR361A00	IC	DAC	07
	IC107	XI686A00	IC	SYSTEM RESET	04
	IC108	XN797A00	IC	OP AMP	02
	IC109	XD830A00	IC	INVERTER	01
	IC110	XC725A00	IC	INVERTER	03
	IC111	XE165A00	IC	NAND	01
	IC112	XD833A00	IC	OR	01
	IC121	XD838A00	IC	BUFFER	04
	IC122	XQ042A00	IC	D-FF	03
	IC123	XD836A00	IC	D FF	02
	IC124	XD835A00	IC	DECODER	02
	IC125	XD838A00	IC	BUFFER	04
	IC131	XD838A00	IC	BUFFER	04

*: New Parts

RANK: Japan only

REF NO.	PART NO.	DESCRIPTION		REMARKS	QTY	RANK
IC132	XH223A00	IC	SN74HC273NSR	D-FF		01
IC133	XJ467A00	IC	TD62503F	DRIVER		03
IC134	XJ467A00	IC	TD62503F	DRIVER		03
IC301	VD473200	Photo Coupler	6N137			05
IC302	XC725A00	IC	SN74HC14NSR	INVERTER		03
JK301	VI466400	DIN Connector	3DIN YKF51-5046			04
K101	VB966900	Style Pin	IMSA-6024			01
-105	VB966900	Style Pin	IMSA-6024			01
L101	VS740100	Chip Inductance	BLM21B751S 2125			03
-144	VS740100	Chip Inductance	BLM21B751S 2125			03
L151	VS740100	Chip Inductance	BLM21B751S 2125			03
-169	VS740100	Chip Inductance	BLM21B751S 2125			03
L307	VS740100	Chip Inductance	BLM21B751S 2125			03
-309	VS740100	Chip Inductance	BLM21B751S 2125			03
L311	VS740100	Chip Inductance	BLM21B751S 2125			03
-315	VS740100	Chip Inductance	BLM21B751S 2125			03
L316	VS740100	Chip Inductance	BLM21B751S 2125			03
LD201	V2693000	LED	SLR-342YY3F YE	DIRECT RECALL		01
-208	V2693000	LED	SLR-342YY3F YE			01
LD209	VR080300	LED	SLR-342MG3F GR	CHECK		01
LD210	V2693000	LED	SLR-342YY3F YE	UTILITY		01
LD211	VN135500	LED Display	LB-303VA			06
Q101	VQ736500	Digital Transistor	DTB123EK			01
-104	VQ736500	Digital Transistor	DTB123EK			01
* SW201	V3835200	Push Switch	2C-2S Non-Lock	DIRECT RECALL1-8,		
* -225	V3835200	Push Switch	2C-2S Non-Lock	SCENE MEMORY Number0-9, ENTER,CHECK,STORE,MEMORY, RECALL,UTILITY		
* X101	V4584600	Ceramic Resonator	20.00M CSTCV20.00			
* X102	V4440400	Ceramic Resonator	11.2M CSTCV11.2			
* X103	V3743900	Ceramic Resonator	30.00M CSTCV30MX			
	UB044100	Monolithic Ceramic Cap.	F 0.01 50V Z	C:141		01
	UB245100	Monolithic Ceramic Cap.	F 0.1 25V Z	C:102,104,109-111,113, 116-118,121-136,138, 139,142,143,145-149, 151-153,155,301,302, 304		01
	UF037100	Electrolytic Cap. (chip)	10 16V	C:112,144		01
	UG038100	Electrolytic Cap. (chip)	100 16V	C:101,103,105-108,114, 115,137,140,154,303		01
	RD154820	Carbon Resistor (chip)	82.0 1/4 J	R:142		01
	RD155150	Carbon Resistor (chip)	150.0 1/4 J	R:178-186		
	RD254330	Carbon Resistor (chip)	33.0 0.1 J	R:106-113,143		01
	RD255220	Carbon Resistor (chip)	220.0 0.1 J	R:139,164,165,301-305		01
	RD256100	Carbon Resistor (chip)	1.0K 0.1 J	R:156-163,169,306		01
	RD256220	Carbon Resistor (chip)	2.2K 0.1 J	R:144,148-155		01
	RD257220	Carbon Resistor (chip)	22.0K 0.1 J	R:101-105,114-130,132, 133,145-147,166-168, 170-177		01
	RD259470	Carbon Resistor (chip)	4.7M 0.1 J	R:131,140,141		01
	HV753100	Flame Proof C. Resistor	1.0 1/4 J	R:187		01
	VC744700	Metal Oxide Film Resistor	75.0 1W J	R:188,189		01
* V4313200		Circuit Board	IN1	(XW201B0)		
* V4467500		Push Button S	CD-GRAY/WHITE	SW101-104,201-204,301-304, 401-404,501-504,601-604, 701-704,801-804(+48V, 20dB,φ)	32	
* V4467700		Push Button S	MX-GREEN/WHITE	SW105,205,305,405,505, 605,705,805(EQ)	8	
	VV307300	LED Spacer				01
CN101	--	Connector, FFC	52045 35P TE	(VQ04840)		
CN102	--	Connector, FFC	52045 35P TE	(VQ04840)		
CN103	--	Connector, FFC	52045 6P TE	(VQ04700)		
CN104	--	Connector, FFC	52045 6P TE	(VQ04700)		
CN105	VV066700	Connector Base Post	M2426XX 7P TE			01
CN106	VV066700	Connector Base Post	M2426XX 7P TE			01
IC101	XF195A00	IC	NJM4580L	OP AMP		04
IC102	XF195A00	IC	NJM4580L	OP AMP		04
IC103	XM356A00	IC	NJM2068L-D	OP AMP		02

*: New Parts

RANK: Japan only

REF NO.	PART NO.	DESCRIPTION		REMARKS	QTY	RANK
-107	XM356A00	IC	NJM2068L-D	OP AMP		02
IC301	XF195A00	IC	NJM4580L	OP AMP		04
IC302	XF195A00	IC	NJM4580L	OP AMP		04
IC303	XM356A00	IC	NJM2068L-D	OP AMP		02
-307	XM356A00	IC	NJM2068L-D	OP AMP		02
IC501	XF195A00	IC	NJM4580L	OP AMP		04
IC502	XF195A00	IC	NJM4580L	OP AMP		04
IC503	XM356A00	IC	NJM2068L-D	OP AMP		02
-507	XM356A00	IC	NJM2068L-D	OP AMP		02
IC701	XF195A00	IC	NJM4580L	OP AMP		04
IC702	XF195A00	IC	NJM4580L	OP AMP		04
IC703	XM356A00	IC	NJM2068L-D	OP AMP		02
-707	XM356A00	IC	NJM2068L-D	OP AMP		02
LD101	VV620800	LED	LT311G-41-C13 RE	+48V		01
LD201	VV620800	LED	LT311G-41-C13 RE	+48V		01
LD301	VV620800	LED	LT311G-41-C13 RE	+48V		01
LD401	VV620800	LED	LT311G-41-C13 RE	+48V		01
LD501	VV620800	LED	LT311G-41-C13 RE	+48V		01
LD601	VV620800	LED	LT311G-41-C13 RE	+48V		01
LD701	VV620800	LED	LT311G-41-C13 RE	+48V		01
LD801	VV620800	LED	LT311G-41-C13 RE	+48V		01
Q101	IC224030	Transistor	2SC2240 GR,BL			01
Q102	IC224030	Transistor	2SC2240 GR,BL			01
Q201	IC224030	Transistor	2SC2240 GR,BL			01
Q202	IC224030	Transistor	2SC2240 GR,BL			01
Q301	IC224030	Transistor	2SC2240 GR,BL			01
Q302	IC224030	Transistor	2SC2240 GR,BL			01
Q401	IC224030	Transistor	2SC2240 GR,BL			01
Q402	IC224030	Transistor	2SC2240 GR,BL			01
Q403	IC1815M0	Transistor	2SC1815 Y,GR			01
Q501	IC224030	Transistor	2SC2240 GR,BL			01
Q502	IC224030	Transistor	2SC2240 GR,BL			01
Q601	IC224030	Transistor	2SC2240 GR,BL			01
Q602	IC224030	Transistor	2SC2240 GR,BL			01
Q701	IC224030	Transistor	2SC2240 GR,BL			01
Q702	IC224030	Transistor	2SC2240 GR,BL			01
Q801	IC224030	Transistor	2SC2240 GR,BL			01
Q802	IC224030	Transistor	2SC2240 GR,BL			01
Q803	IC1815M0	Transistor	2SC1815 Y,GR			01
SW101	VZ587700	Push Switch	2C-2S Lock	+48V,20dB,φ,80,EQ		01
-105	VZ587700	Push Switch	2C-2S Lock			01
SW201	VZ587700	Push Switch	2C-2S Lock	+48V,20dB,φ,80,EQ		01
-205	VZ587700	Push Switch	2C-2S Lock			01
SW301	VZ587700	Push Switch	2C-2S Lock	+48V,20dB,φ,80,EQ		01
-305	VZ587700	Push Switch	2C-2S Lock			01
SW401	VZ587700	Push Switch	2C-2S Lock	+48V,20dB,φ,80,EQ		01
-405	VZ587700	Push Switch	2C-2S Lock			01
SW501	VZ587700	Push Switch	2C-2S Lock	+48V,20dB,φ,80,EQ		01
-505	VZ587700	Push Switch	2C-2S Lock			01
SW601	VZ587700	Push Switch	2C-2S Lock	+48V,20dB,φ,80,EQ		01
-605	VZ587700	Push Switch	2C-2S Lock			01
SW701	VZ587700	Push Switch	2C-2S Lock	+48V,20dB,φ,80,EQ		01
-705	VZ587700	Push Switch	2C-2S Lock			01
SW801	VZ587700	Push Switch	2C-2S Lock	+48V,20dB,φ,80,EQ		01
-805	VZ587700	Push Switch	2C-2S Lock			01
VR101	VU804500	Rotary Variable Resistor	RD 5.0K RK09K113	GAIN		04
VR102	V3161000	Rotary Variable Resistor	B 50.0K RK09D113	EQ(LO)		04
VR103	V3161000	Rotary Variable Resistor	B 50.0K RK09D113	EQ(HI)		04
VR104	VZ611200	Rotary Variable Resistor	C 100K RK12L123	EQ(HI-MID)		05
VR105	V3161100	Rotary Variable Resistor	W 20.0K RK09D113	EQ(HI-MID)		04
VR106	VZ611200	Rotary Variable Resistor	C 100K RK12L123	EQ(LO-MID)		05
VR107	V3161100	Rotary Variable Resistor	W 20.0K RK09D113	EQ(LO-MID)		04
VR201	VU804500	Rotary Variable Resistor	RD 5.0K RK09K113	GAIN		04
VR202	V3161000	Rotary Variable Resistor	B 50.0K RK09D113	EQ(LO)		04
VR203	V3161000	Rotary Variable Resistor	B 50.0K RK09D113	EQ(HI)		04
VR204	VZ611200	Rotary Variable Resistor	C 100K RK12L123	EQ(HI-MID)		05
VR205	V3161100	Rotary Variable Resistor	W 20.0K RK09D113	EQ(HI-MID)		04
VR206	VZ611200	Rotary Variable Resistor	C 100K RK12L123	EQ(LO-MID)		05
VR207	V3161100	Rotary Variable Resistor	W 20.0K RK09D113	EQ(LO-MID)		04
VR301	VU804500	Rotary Variable Resistor	RD 5.0K RK09K113	GAIN		04

*: New Parts

RANK: Japan only

REF NO.	PART NO.	DESCRIPTION		REMARKS	QTY	RANK
VR302	V3161000	Rotary Variable Resistor	B 50.0K RK09D113	EQ(LO)		04
VR303	V3161000	Rotary Variable Resistor	B 50.0K RK09D113	EQ(HI)		04
VR304	VZ611200	Rotary Variable Resistor	C 100K RK12L123	EQ(HI-MID)		05
VR305	V3161100	Rotary Variable Resistor	W 20.0K RK09D113	EQ(HI-MID)		04
VR306	VZ611200	Rotary Variable Resistor	C 100K RK12L123	EQ(LO-MID)		05
VR307	V3161100	Rotary Variable Resistor	W 20.0K RK09D113	EQ(LO-MID)		04
VR401	VU804500	Rotary Variable Resistor	RD 5.0K RK09K113	GAIN		04
VR402	V3161000	Rotary Variable Resistor	B 50.0K RK09D113	EQ(LO)		04
VR403	V3161000	Rotary Variable Resistor	B 50.0K RK09D113	EQ(HI)		04
VR404	VZ611200	Rotary Variable Resistor	C 100K RK12L123	EQ(HI-MID)		05
VR405	V3161100	Rotary Variable Resistor	W 20.0K RK09D113	EQ(HI-MID)		04
VR406	VZ611200	Rotary Variable Resistor	C 100K RK12L123	EQ(LO-MID)		05
VR407	V3161100	Rotary Variable Resistor	W 20.0K RK09D113	EQ(LO-MID)		04
VR501	VU804500	Rotary Variable Resistor	RD 5.0K RK09K113	GAIN		04
VR502	V3161000	Rotary Variable Resistor	B 50.0K RK09D113	EQ(LO)		04
VR503	V3161000	Rotary Variable Resistor	B 50.0K RK09D113	EQ(HI)		04
VR504	VZ611200	Rotary Variable Resistor	C 100K RK12L123	EQ(HI-MID)		05
VR505	V3161100	Rotary Variable Resistor	W 20.0K RK09D113	EQ(HI-MID)		04
VR506	VZ611200	Rotary Variable Resistor	C 100K RK12L123	EQ(LO-MID)		05
VR507	V3161100	Rotary Variable Resistor	W 20.0K RK09D113	EQ(LO-MID)		04
VR601	VU804500	Rotary Variable Resistor	RD 5.0K RK09K113	GAIN		04
VR602	V3161000	Rotary Variable Resistor	B 50.0K RK09D113	EQ(LO)		04
VR603	V3161000	Rotary Variable Resistor	B 50.0K RK09D113	EQ(HI)		04
VR604	VZ611200	Rotary Variable Resistor	C 100K RK12L123	EQ(HI-MID)		05
VR605	V3161100	Rotary Variable Resistor	W 20.0K RK09D113	EQ(HI-MID)		04
VR606	VZ611200	Rotary Variable Resistor	C 100K RK12L123	EQ(LO-MID)		05
VR607	V3161100	Rotary Variable Resistor	W 20.0K RK09D113	EQ(LO-MID)		04
VR701	VU804500	Rotary Variable Resistor	RD 5.0K RK09K113	GAIN		04
VR702	V3161000	Rotary Variable Resistor	B 50.0K RK09D113	EQ(LO)		04
VR703	V3161000	Rotary Variable Resistor	B 50.0K RK09D113	EQ(HI)		04
VR704	VZ611200	Rotary Variable Resistor	C 100K RK12L123	EQ(HI-MID)		05
VR705	V3161100	Rotary Variable Resistor	W 20.0K RK09D113	EQ(HI-MID)		04
VR706	VZ611200	Rotary Variable Resistor	C 100K RK12L123	EQ(LO-MID)		05
VR707	V3161100	Rotary Variable Resistor	W 20.0K RK09D113	EQ(LO-MID)		04
VR801	VU804500	Rotary Variable Resistor	RD 5.0K RK09K113	GAIN		04
VR802	V3161000	Rotary Variable Resistor	B 50.0K RK09D113	EQ(LO)		04
VR803	V3161000	Rotary Variable Resistor	B 50.0K RK09D113	EQ(HI)		04
VR804	VZ611200	Rotary Variable Resistor	C 100K RK12L123	EQ(HI-MID)		05
VR805	V3161100	Rotary Variable Resistor	W 20.0K RK09D113	EQ(HI-MID)		04
VR806	VZ611200	Rotary Variable Resistor	C 100K RK12L123	EQ(LO-MID)		05
VR807	V3161100	Rotary Variable Resistor	W 20.0K RK09D113	EQ(LO-MID)		04
	VV061500	Mylar Capacitor	0.012 50V J	C:131,231,331,431,531, 631,731,831		01
	VV062300	Mylar Capacitor	0.039 50V J	C:123,223,323,423,523, 523,623,723,823		01
	VV062700	Mylar Capacitor	0.082 50V J	C:115,116,215,216,315, 316,415,416,515,516, 615,616,715,716,815, 816		01
	VV190000	Mylar Capacitor	820P 50V J	C:124,224,324,424,524, 624,724,824		01
	VZ597000	Mylar Capacitor	2400P 50V J	C:127,227,327,427,527, 627,727,827		01
	VZ597100	Mylar Capacitor	6200P 50V J	C:128,228,328,428,528, 628,728,828		01
	VZ597200	Mylar Capacitor	0.03 50V J	C:132,232,332,432,532, 632,732,832		01
	VV064400	Monolithic Mylar Capacitor	0.82 50V J	C:114,214,314,414,514, 614,714,814		03
	VZ352700	Ceramic Capacitor-SL	10P 50V J	C:109,112,209,212,309, 312,409,412,509,512, 609,612,709,712,809, 812		01
	VZ352800	Ceramic Capacitor-SL	22P 50V J	C:130,134,230,234,330, 334,430,434,530,534, 630,634,730,734,830, 834		01
	VZ353000	Ceramic Capacitor-SL	33P 50V J	C:111,211,311,411,511, 611,711,811		01
	VZ353200	Ceramic Capacitor-SL	47P 50V J	C:120,125,220,225,320,		01

*: New Parts

RANK: Japan only

REF NO.	PART NO.	DESCRIPTION		REMARKS	QTY	RANK
	VZ353500	Ceramic Capacitor-SL	100P 50V J	325,420,425,520,525, 620,625,720,725,820, 825 C:117,119,126,129,133, 217,219,226,229,233, 317,319,326,329,333, 417,419,426,429,433, 517,519,526,529,533, 617,619,626,629,633, 717,719,726,729,733, 817,819,826,829,833		01
	VZ353600	Ceramic Cap.-B	220P 50V K	C:110,210,310,410,510, 610,710,810		01
	VZ353700	Ceramic Cap.-B	330P 50V K	C:104,105,204,205,304, 305,404,405,504,505, 604,605,704,705,804, 805		01
	VZ353800	Ceramic Cap.-B	470P 50V K	C:106,108,206,208,306, 308,406,408,506,508, 606,608,706,708,806, 808		01
	VZ354000	Ceramic Capacitor-F	0.01 50V Z	C:136-139,337-340, 537-540,737-740		01
	UJ847100	Electrolytic Cap.	10.00 25.0V	C:118,122,218,222,318, 322,418,422,518,522, 618,622,718,722,818, 822		01
	UJ847470	Electrolytic Cap.	47.00 25.0V	C:135,235,335,435,535, 635,735,835		01
	UJ867470	Electrolytic Cap.	47.00 50.0V	C:101,201,301,401,501, 601,701,801		01
	UR858100	Electrolytic Cap.	100 35V	C:141,142,341,342,541, 542,741,742		01
*	V4270900	Electrolytic Cap.	10.00 25.0V	C:121,221,321,421,521, 621,721,821		01
	VV330700	Electrolytic Cap.	470 10.0V	C:107,207,307,407,507, 607,707,807		01
	VV488800	Electrolytic Cap.-LLM	10.00 50.0V	C:102,103,202,203,302, 303,402,403,502,503, 602,603,702,703,802, 803		01
*	V4587500	Electrolytic Cap.-NP	10.00 25.0V	C:113,213,313,413,513, 613,713,813		01
	HF454100	Carbon Resistor	10.0 1/4 J	R:110,111,114,121,129, 133,149,210,211,214, 221,229,233,249,310, 311,314,321,329,333, 349,410,411,414,421, 429,433,449,510,511, 514,521,529,533,549, 610,611,614,621,629, 633,649,710,711,714, 721,729,733,749,810, 811,814,821,829,833, 849		01
	HF455100	Carbon Resistor	100.0 1/4 J	R:452,852		01
	HF456150	Carbon Resistor	1.5K 1/4 J	R:453,853		01
	HF456270	Carbon Resistor	2.7K 1/4 J	R:126,226,326,426,526, 626,726,826		01
	HF456470	Carbon Resistor	4.7K 1/4 J	R:137,237,337,437,537, 637,737,837		01
	HF456510	Carbon Resistor	5.1K 1/4 J	R:143,144,147,148,243, 244,247,248,343,344, 347,348,443,444,447, 448,543,544,547,548, 643,644,647,648,743, 744,747,748,843,844, 847,848		01
	HF456560	Carbon Resistor	5.6K 1/4 J	R:140,240,340,440,540, 640,740,840		01

*: New Parts

RANK: Japan only

REF NO.	PART NO.	DESCRIPTION		REMARKS	QTY	RANK
	HF456820	Carbon Resistor	8.2K 1/4 J	R:141,142,145,146,241, 242,245,246,341,342, 345,346,441,442,445, 446,541,542,545,546, 641,642,645,646,741, 742,745,746,841,842, 845,846		01
	HF457100	Carbon Resistor	10.0K 1/4 J	R:131,132,136,139,231, 232,236,239,331,332, 336,339,431,432,436, 439,531,532,536,539, 631,632,636,639,731, 732,736,739,831,832, 836,839		01
	HF457120	Carbon Resistor	12.0K 1/4 J	R:127,227,327,427,454, 527,627,727,827,854		01
	HF457330	Carbon Resistor	33.0K 1/4 J	R:138,238,338,438,538, 638,738,838		01
	HF457470	Carbon Resistor	47.0K 1/4 J	R:150,250,350,450,550, 650,750,850		01
	HF457510	Carbon Resistor	51.0K 1/4 J	R:128,228,328,428,528, 628,728,828		01
	HF458100	Carbon Resistor	100.0K 1/4 J	R:102,202,302,402,502, 602,702,802		01
	HF458220	Carbon Resistor	220.0K 1/4 J	R:125,130,134,135,151, 225,230,234,235,251, 325,330,334,335,351, 425,430,434,435,451, 625,630,634,635,651, 725,730,734,735,751, 825,830,834,835,851		01
	VV058400	Flame Proof C. Resistor	390.0 1/4 J	R:101,201,301,401,501, 601,701,801		01
	VV064900	Metal Film Resistor	20.0 1/4 F	R:117,217,317,417,517, 617,717,817		01
	VV065100	Metal Film Resistor	2.2K 1/4 F	R:115,116,215,216,315, 316,415,416,515,516, 615,616,715,716,815, 816		01
	VV065200	Metal Film Resistor	4.7K 1/4 F	R:105,107,123,124,205, 207,223,224,305,307, 323,324,405,407,423, 424,505,507,523,524, 605,607,623,624,705, 707,723,724,805,807, 823,824		05
	VV065300	Metal Film Resistor	6.8K 1/4 F	R:103,104,203,204,303, 304,403,404,503,504, 603,604,703,704,803, 804		01
	VV065400	Metal Film Resistor	8.2K 1/4 F	R:119,120,219,220,319, 320,419,420,519,520, 619,620,719,720,819, 820		01
	VV065500	Metal Film Resistor	10K 1/4 F	R:108,208,308,408,508, 608,708,808		01
	VV065900	Metal Film Resistor	24K 1/4 F	R:118,122,218,222,318, 322,418,422,518,522, 618,622,718,722,818, 822		01
	VV066100	Metal Film Resistor	47K 1/4 F	R:112,113,212,213,312, 313,412,413,512,513, 612,613,712,713,812, 813		01
	VZ598300	Metal Film Resistor	510.0 1/4 F	R:106,206,306,406,506, 606,706,806		01
*	V4313300	Circuit Board	IN2	(XV202B0)		
	V3297600	Earth Terminal				03

*: New Parts

RANK: Japan only

REF NO.	PART NO.	DESCRIPTION		REMARKS	QTY	RANK
*	V4467500	Push Button S	CD-GRAY/WHITE	SW102,103,202,203,302, 303,402,403,502,503,602, 603,702,703,802,803(PRE (AUX7-10,AUX11-14))	16	
*	V4467800	Push Button S	MX-BLUE/WHITE	SW101,201,301,401,501, 601,701,801(PRE(AUX3-6)) (VQ04700)	8	
CN201	--	Connector, FFC	52045 6P TE			01
CN202	--	Connector, FFC	52045 6P TE			01
CN203	VN394900	Connector, FFC	52045 14P TE			01
CN204	VN394900	Connector, FFC	52045 14P TE			01
CN205	VV066700	Connector Base Post	M2426XX 7P TE			01
CN206	VV066700	Connector Base Post	M2426XX 7P TE			01
CN207	VV067000	Connector Base Post	M2426XX 10P TE			01
CN208	VV067000	Connector Base Post	M2426XX 10P TE			01
SW101	VZ587700	Push Switch	2C-2S Lock	PRE(AUX3-6,AUX7-10, AUX11-14)	01	
-103	VZ587700	Push Switch	2C-2S Lock	PRE(AUX3-6,AUX7-10, AUX11-14)	01	
SW201	VZ587700	Push Switch	2C-2S Lock	PRE(AUX3-6,AUX7-10, AUX11-14)	01	
-203	VZ587700	Push Switch	2C-2S Lock	PRE(AUX3-6,AUX7-10, AUX11-14)	01	
SW301	VZ587700	Push Switch	2C-2S Lock	PRE(AUX3-6,AUX7-10, AUX11-14)	01	
-303	VZ587700	Push Switch	2C-2S Lock	PRE(AUX3-6,AUX7-10, AUX11-14)	01	
SW401	VZ587700	Push Switch	2C-2S Lock	PRE(AUX3-6,AUX7-10, AUX11-14)	01	
-403	VZ587700	Push Switch	2C-2S Lock	PRE(AUX3-6,AUX7-10, AUX11-14)	01	
SW501	VZ587700	Push Switch	2C-2S Lock	PRE(AUX3-6,AUX7-10, AUX11-14)	01	
-503	VZ587700	Push Switch	2C-2S Lock	PRE(AUX3-6,AUX7-10, AUX11-14)	01	
SW601	VZ587700	Push Switch	2C-2S Lock	PRE(AUX3-6,AUX7-10, AUX11-14)	01	
-603	VZ587700	Push Switch	2C-2S Lock	PRE(AUX3-6,AUX7-10, AUX11-14)	01	
SW701	VZ587700	Push Switch	2C-2S Lock	PRE(AUX3-6,AUX7-10, AUX11-14)	01	
-703	VZ587700	Push Switch	2C-2S Lock	PRE(AUX3-6,AUX7-10, AUX11-14)	01	
SW801	VZ587700	Push Switch	2C-2S Lock	PRE(AUX3-6,AUX7-10, AUX11-14)	01	
-803	VZ587700	Push Switch	2C-2S Lock	PRE(AUX3-6,AUX7-10, AUX11-14)	01	
VR101	VZ660000	Rotary Variable Resistor	B 20K RK09D113	AUX1-14	01	
-114	VZ660000	Rotary Variable Resistor	B 20K RK09D113	AUX1-14	01	
VR201	VZ660000	Rotary Variable Resistor	B 20K RK09D113	AUX1-14	01	
-214	VZ660000	Rotary Variable Resistor	B 20K RK09D113	AUX1-14	01	
VR301	VZ660000	Rotary Variable Resistor	B 20K RK09D113	AUX1-14	01	
-314	VZ660000	Rotary Variable Resistor	B 20K RK09D113	AUX1-14	01	
VR401	VZ660000	Rotary Variable Resistor	B 20K RK09D113	AUX1-14	01	
-414	VZ660000	Rotary Variable Resistor	B 20K RK09D113	AUX1-14	01	
VR501	VZ660000	Rotary Variable Resistor	B 20K RK09D113	AUX1-14	01	
-514	VZ660000	Rotary Variable Resistor	B 20K RK09D113	AUX1-14	01	
VR601	VZ660000	Rotary Variable Resistor	B 20K RK09D113	AUX1-14	01	
-614	VZ660000	Rotary Variable Resistor	B 20K RK09D113	AUX1-14	01	
VR701	VZ660000	Rotary Variable Resistor	B 20K RK09D113	AUX1-14	01	
-714	VZ660000	Rotary Variable Resistor	B 20K RK09D113	AUX1-14	01	
VR801	VZ660000	Rotary Variable Resistor	B 20K RK09D113	AUX1-14	01	
-814	VZ660000	Rotary Variable Resistor	B 20K RK09D113	AUX1-14	01	
	VZ353900	Ceramic Cap.-B	1000P 50V K	C:101-112	01	
	HF457180	Carbon Resistor	18.0K 1/4 J	R:101-114,201-214, 301-314,401-414, 501-514,601-614, 701-714,801,814	01	
*	V4313500	Circuit Board	IN3	(XW203B0)		03
	V3297600	Earth Terminal				
*	V4467500	Push Button S	CD-GRAY/WHITE	SW102-105,202-205,302-305, 402-405,502-505,602-605, 702-705,802-805(1-2,3-4, 5-6,7-8)	32	
*	V4468000	Push Button S	RED/WHITE	SW106,108,206,208,306, 308,406,408,506,508,606, 608,706,708,806,808 (ST,LCR)	16	
*	V4468200	Push Button S	YELLOW/WHITE	SW107,207,307,407,507, 607,707,807(MONO)	8	
*	V4469400	Push Button L	CL-GRAY/RED	SW101,201,301,401,501, 601,701,801(PFL)	8	
	VV307300	LED Spacer				01
	VZ968600	Button	NO.947 CD-GRAY	SW109,209,309,409,509, 609,709,809(ON/EDIT)	8	01
CN301	VN394900	Connector, FFC	52045 14P TE			01

*: New Parts

RANK: Japan only

REF NO.	PART NO.	DESCRIPTION		REMARKS	QTY	RANK
CN302	VN394900	Connector, FFC	52045 14P TE			01
CN303	--	Connector, FFC	52045 6P TE	(VQ04700)		
-306	--	Connector, FFC	52045 6P TE	(VQ04700)		
CN307	VP682200	Connector, FFC	52045 8P TE			01
CN308	VP127700	Connector, FFC	52045 24P TE			01
CN309	VP127700	Connector, FFC	52045 24P TE			01
CN310	VP682200	Connector, FFC	52045 8P TE			01
CN311	--	Connector Base Post	M2426XX 13P TE	(VV06730)		
CN312	--	Connector Base Post	M2426XX 13P TE	(VV06730)		
CN313	VV066500	Connector Base Post	M2426XX 5P TE			01
CN314	VV066500	Connector Base Post	M2426XX 5P TE			01
CN315	VV066400	Connector Base Post	M2426XX 4P TE			01
CN316	VV066500	Connector Base Post	M2426XX 5P TE			01
CN317	VV066300	Connector Base Post	M2426XX 3P TE			01
D101	VD631600	Diode	1SS133,176,HSS104			01
D201	VD631600	Diode	1SS133,176,HSS104			01
D301	VD631600	Diode	1SS133,176,HSS104			01
D401	VD631600	Diode	1SS133,176,HSS104			01
D501	VD631600	Diode	1SS133,176,HSS104			01
D601	VD631600	Diode	1SS133,176,HSS104			01
D701	VD631600	Diode	1SS133,176,HSS104			01
D801	VD631600	Diode	1SS133,176,HSS104			01
IC101	XF195A00	IC	NJM4580L	OP AMP		04
IC102	XF195A00	IC	NJM4580L	OP AMP		04
IC103	XA552A00	IC	BA6144	METER RIVER		03
IC203	XA552A00	IC	BA6144	METER RIVER		03
IC301	XF195A00	IC	NJM4580L	OP AMP		04
IC302	XF195A00	IC	NJM4580L	OP AMP		04
IC303	XA552A00	IC	BA6144	METER RIVER		03
IC403	XA552A00	IC	BA6144	METER RIVER		03
IC501	XF195A00	IC	NJM4580L	OP AMP		04
IC502	XF195A00	IC	NJM4580L	OP AMP		04
IC503	XA552A00	IC	BA6144	METER RIVER		03
IC603	XA552A00	IC	BA6144	METER RIVER		03
IC701	XF195A00	IC	NJM4580L	OP AMP		04
IC702	XF195A00	IC	NJM4580L	OP AMP		04
IC703	XA552A00	IC	BA6144	METER RIVER		03
IC803	XA552A00	IC	BA6144	METER RIVER		03
LD101	VV621000	LED	LT321-41-C13 GR	SIGNAL		01
LD102	VV938100	LED	LT331-41-C13 YE	NOM		01
LD103	VV620800	LED	LT311G-41-C13 RE	PEAK		01
LD104	VV938100	LED	LT331-41-C13 YE	ON/EDIT(ON)		01
LD105	VV621000	LED	LT321-41-C13 GR	ON/EDIT(CHECK)		01
LD106	VV938100	LED	LT331-41-C13 YE	PFL		01
LD107	VV620800	LED	LT311G-41-C13 RE	LCR		01
LD201	VV621000	LED	LT321-41-C13 GR	SIGNAL		01
LD202	VV938100	LED	LT331-41-C13 YE	NOM		01
LD203	VV620800	LED	LT311G-41-C13 RE	PEAK		01
LD204	VV938100	LED	LT331-41-C13 YE	ON/EDIT(ON)		01
LD205	VV621000	LED	LT321-41-C13 GR	ON/EDIT(CHECK)		01
LD206	VV938100	LED	LT331-41-C13 YE	PFL		01
LD207	VV620800	LED	LT311G-41-C13 RE	LCR		01
LD301	VV621000	LED	LT321-41-C13 GR	SIGNAL		01
LD302	VV938100	LED	LT331-41-C13 YE	NOM		01
LD303	VV620800	LED	LT311G-41-C13 RE	PEAK		01
LD304	VV938100	LED	LT331-41-C13 YE	ON/EDIT(ON)		01
LD305	VV621000	LED	LT321-41-C13 GR	ON/EDIT(CHECK)		01
LD306	VV938100	LED	LT331-41-C13 YE	PFL		01
LD307	VV620800	LED	LT311G-41-C13 RE	LCR		01
LD401	VV621000	LED	LT321-41-C13 GR	SIGNAL		01
LD402	VV938100	LED	LT331-41-C13 YE	NOM		01
LD403	VV620800	LED	LT311G-41-C13 RE	PEAK		01
LD404	VV938100	LED	LT331-41-C13 YE	ON/EDIT(ON)		01
LD405	VV621000	LED	LT321-41-C13 GR	ON/EDIT(CHECK)		01
LD406	VV938100	LED	LT331-41-C13 YE	PFL		01
LD407	VV620800	LED	LT311G-41-C13 RE	LCR		01
LD501	VV621000	LED	LT321-41-C13 GR	SIGNAL		01
LD502	VV938100	LED	LT331-41-C13 YE	NOM		01
LD503	VV620800	LED	LT311G-41-C13 RE	PEAK		01
LD504	VV938100	LED	LT331-41-C13 YE	ON/EDIT(ON)		01

*: New Parts

RANK: Japan only

REF NO.	PART NO.	DESCRIPTION		REMARKS	QTY	RANK
LD505	VV621000	LED	LT321-41-C13 GR	ON/EDIT(CHECK)		01
LD506	VV938100	LED	LT331-41-C13 YE	PFL		01
LD507	VV620800	LED	LT311G-41-C13 RE	LCR		01
LD601	VV621000	LED	LT321-41-C13 GR	SIGNAL		01
LD602	VV938100	LED	LT331-41-C13 YE	NOM		01
LD603	VV620800	LED	LT311G-41-C13 RE	PEAK		01
LD604	VV938100	LED	LT331-41-C13 YE	ON/EDIT(ON)		01
LD605	VV621000	LED	LT321-41-C13 GR	ON/EDIT(CHECK)		01
LD606	VV938100	LED	LT331-41-C13 YE	PFL		01
LD607	VV620800	LED	LT311G-41-C13 RE	LCR		01
LD701	VV621000	LED	LT321-41-C13 GR	SIGNAL		01
LD702	VV938100	LED	LT331-41-C13 YE	NOM		01
LD703	VV620800	LED	LT311G-41-C13 RE	PEAK		01
LD704	VV938100	LED	LT331-41-C13 YE	ON/EDIT(ON)		01
LD705	VV621000	LED	LT321-41-C13 GR	ON/EDIT(CHECK)		01
LD706	VV938100	LED	LT331-41-C13 YE	PFL		01
LD707	VV620800	LED	LT311G-41-C13 RE	LCR		01
LD801	VV621000	LED	LT321-41-C13 GR	SIGNAL		01
LD802	VV938100	LED	LT331-41-C13 YE	NOM		01
LD803	VV620800	LED	LT311G-41-C13 RE	PEAK		01
LD804	VV938100	LED	LT331-41-C13 YE	ON/EDIT(ON)		01
LD805	VV621000	LED	LT321-41-C13 GR	ON/EDIT(CHECK)		01
LD806	VV938100	LED	LT331-41-C13 YE	PFL		01
LD807	VV620800	LED	LT311G-41-C13 RE	LCR		01
Q401	IC1815M0	Transistor	2SC1815 Y,GR			01
Q801	IC1815M0	Transistor	2SC1815 Y,GR			01
RY101	VM640200	Relay	DC RY 12W-OH-K			05
RY201	VM640200	Relay	DC RY 12W-OH-K			05
RY301	VM640200	Relay	DC RY 12W-OH-K			05
RY401	VM640200	Relay	DC RY 12W-OH-K			05
RY501	VM640200	Relay	DC RY 12W-OH-K			05
RY601	VM640200	Relay	DC RY 12W-OH-K			05
RY701	VM640200	Relay	DC RY 12W-OH-K			05
RY801	VM640200	Relay	DC RY 12W-OH-K			05
SW101	VZ587700	Push Switch	2C-2S Lock	PFL,1-2,3-4,5-6,7-8,ST,		01
-107	VZ587700	Push Switch	2C-2S Lock	MONO		01
SW108	VZ251800	Push Switch	ESB68149	LCR		03
* SW109	V3835200	Push Switch	2C-2S Non-Lock	ON/EDIT		
SW201	VZ587700	Push Switch	2C-2S Lock	PFL,1-2,3-4,5-6,7-8,ST,		01
-207	VZ587700	Push Switch	2C-2S Lock	MONO		01
SW208	VZ251800	Push Switch	ESB68149	LCR		03
* SW209	V3835200	Push Switch	2C-2S Non-Lock	ON/EDIT		
SW301	VZ587700	Push Switch	2C-2S Lock	PFL,1-2,3-4,5-6,7-8,ST,		01
-307	VZ587700	Push Switch	2C-2S Lock	MONO		01
SW308	VZ251800	Push Switch	ESB68149	LCR		03
* SW309	V3835200	Push Switch	2C-2S Non-Lock	ON/EDIT		
SW401	VZ587700	Push Switch	2C-2S Lock	PFL,1-2,3-4,5-6,7-8,ST,		01
-407	VZ587700	Push Switch	2C-2S Lock	MONO		01
SW408	VZ251800	Push Switch	ESB68149	LCR		03
* SW409	V3835200	Push Switch	2C-2S Non-Lock	ON/EDIT		
SW501	VZ587700	Push Switch	2C-2S Lock	PFL,1-2,3-4,5-6,7-8,ST,		01
-507	VZ587700	Push Switch	2C-2S Lock	MONO		01
SW508	VZ251800	Push Switch	ESB68149	LCR		03
* SW509	V3835200	Push Switch	2C-2S Non-Lock	ON/EDIT		
SW601	VZ587700	Push Switch	2C-2S Lock	PFL,1-2,3-4,5-6,7-8,ST,		01
-607	VZ587700	Push Switch	2C-2S Lock	MONO		01
SW608	VZ251800	Push Switch	ESB68149	LCR		03
* SW609	V3835200	Push Switch	2C-2S Non-Lock	ON/EDIT		
SW701	VZ587700	Push Switch	2C-2S Lock	PFL,1-2,3-4,5-6,7-8,ST,		01
-707	VZ587700	Push Switch	2C-2S Lock	MONO		01
SW708	VZ251800	Push Switch	ESB68149	LCR		03
* SW709	V3835200	Push Switch	2C-2S Non-Lock	ON/EDIT		
SW801	VZ587700	Push Switch	2C-2S Lock	PFL,1-2,3-4,5-6,7-8,ST,		01
-807	VZ587700	Push Switch	2C-2S Lock	MONO		01
SW808	VZ251800	Push Switch	ESB68149	LCR		03
* SW809	V3835200	Push Switch	2C-2S Non-Lock	ON/EDIT		
* VR101	V5114600	Slide Variable Resistor	D 10.0K RSA0N11S	FADER		05
* VR201	V5114600	Slide Variable Resistor	D 10.0K RSA0N11S	FADER		05
* VR301	V5114600	Slide Variable Resistor	D 10.0K RSA0N11S	FADER		05
* VR401	V5114600	Slide Variable Resistor	D 10.0K RSA0N11S	FADER		05

*: New Parts

RANK: Japan only

REF NO.	PART NO.	DESCRIPTION		REMARKS	QTY	RANK
* VR501	V5114600	Slide Variable Resistor	D 10.0K RSA0N11S	FADER		05
* VR601	V5114600	Slide Variable Resistor	D 10.0K RSA0N11S	FADER		05
* VR701	V5114600	Slide Variable Resistor	D 10.0K RSA0N11S	FADER		05
* VR801	V5114600	Slide Variable Resistor	D 10.0K RSA0N11S	FADER		05
	VZ353200	Ceramic Capacitor-SL	47P 50V J	C:104,204,304,404,504, 604,704,804		01
	VZ353400	Ceramic Capacitor-SL	68P 50V J	C:110,210,310,410,510, 610,710,810		01
	VZ353500	Ceramic Capacitor-SL	100P 50V J	C:102,103,108,109,202, 203,208,209,302,303, 308,309,402,403,408, 409,502,503,508,509, 602,603,608,609,702, 703,708,709,802,803, 808,809		01
	VZ353900	Ceramic Cap.-B	1000P 50V K	C:106,206,306,406,506, 606,706,806		01
	VZ354000	Ceramic Capacitor-F	0.01 50V Z	C:115-118,315-318, 515-518,715-718		01
	UJ847100	Electrolytic Cap.	10.00 25.0V	C:101,107,112-114,201, 207,212-214,301,307, 312-314,401,407, 412-414,501,507, 512-514,601,607, 612-614,701,707, 712-714,801,807,812-814		01
	UJ847470	Electrolytic Cap.	47.00 25.0V	C:105,111,205,211,305, 311,405,411,505,511, 605,611,705,711,805, 811		01
	HF454100	Carbon Resistor	10.0 1/4 J	R:113,213,313,413,513, 513,613,713,813		01
	HF454220	Carbon Resistor	22.0 1/4 J	R:103,106,203,206,303, 306,403,406,503,506, 603,606,703,706,803, 806		01
	HF455100	Carbon Resistor	100.0 1/4 J	R:118,218,318,418,437, 518,618,718,818,837		01
	HF455220	Carbon Resistor	220.0 1/4 J	R:108,110,208,210,308, 310,408,410,508,510, 608,610,708,710,808, 810		01
	HF456120	Carbon Resistor	1.2K 1/4 J	R:139-141,239-241, 339-341,439-441, 539-541,639-641, 739-741,839-841		01
	HF456150	Carbon Resistor	1.5K 1/4 J	R:436,836		01
	HF456180	Carbon Resistor	1.8K 1/4 J	R:117,134,138,217,234, 238,317,334,338,417, 434,438,517,534,538, 617,634,638,717,734, 738,817,834,838		01
	HF456470	Carbon Resistor	4.7K 1/4 J	R:111,133,211,233,311, 333,411,433,511,533, 611,633,711,733,811, 833		01
	HF456510	Carbon Resistor	5.1K 1/4 J	R:101,102,104,105,201, 202,204,205,301,302, 304,305,401,402,404, 405,501,502,504,505, 601,602,604,605,701, 702,704,705,801,802, 804,805		01
	HF457100	Carbon Resistor	10.0K 1/4 J	R:112,212,312,412,512, 612,712,812		01
	HF457120	Carbon Resistor	12.0K 1/4 J	R:435,835		01
	HF457180	Carbon Resistor	18.0K 1/4 J	R:119-130,219-230, 319-330,419-430, 519-530,619-630, 719-730,819-830		01

*: New Parts

RANK: Japan only

REF NO.	PART NO.	DESCRIPTION		REMARKS	QTY	RANK
	HF457220	Carbon Resistor	22.0K 1/4 J	R:131,231,331,431,531, 631,731,831		01
	HF457470	Carbon Resistor	47.0K 1/4 J	R:109,209,309,409,509, 609,709,809		01
	HF457560	Carbon Resistor	56.0K 1/4 J	R:132,232,332,432,532, 632,732,832		01
	HF458100	Carbon Resistor	100.0K 1/4 J	R:107,114-116,207, 214-216,307,314-316, 407,414-416,507, 514-516,607,614-616, 707,714-716,807,814-816		01
*	AAX09010	Circuit Board	IN4	(XW204B0)		
CN401	--	Connector, FFC	52045 6P TE	(VQ04700)		
-404	--	Connector, FFC	52045 6P TE	(VQ04700)		
CN405	VV067800	Connector Base Post	M2426XXR 4P SE			01
CN406	VQ047500	Connector, FFC	52045 20P TE			01
CN407	VQ047500	Connector, FFC	52045 20P TE			01
CN408	VV067900	Connector Base Post	M2426XXR 5P SE			01
* CN409	VV067700	Connector Base Post	M2426XXR 3P SE			01
* CN410	VV067600	Connector Base Post	M2426XXR 2P SE			
* CN411	VV067600	Connector Base Post	M2426XXR 2P SE			
IC101	XP451A00	IC	PM25 LZ95300	INTERFACE		04
IC102	IR000200	IC	TC74HC02AP	NOR		03
IC201	XP451A00	IC	PM25 LZ95300	INTERFACE		04
IC301	XP451A00	IC	PM25 LZ95300	INTERFACE		04
IC302	IR000200	IC	TC74HC02AP	NOR		03
IC401	XP451A00	IC	PM25 LZ95300	INTERFACE		04
Q101	IC1815M0	Transistor	2SC1815 Y,GR			01
-104	IC1815M0	Transistor	2SC1815 Y,GR			01
Q105	IA101590	Transistor	2SA1015 O,Y			01
-108	IA101590	Transistor	2SA1015 O,Y			01
Q109	IC1815M0	Transistor	2SC1815 Y,GR			01
Q201	IC1815M0	Transistor	2SC1815 Y,GR			01
-204	IC1815M0	Transistor	2SC1815 Y,GR			01
Q205	IA101590	Transistor	2SA1015 O,Y			01
-208	IA101590	Transistor	2SA1015 O,Y			01
Q209	IC1815M0	Transistor	2SC1815 Y,GR			01
Q301	IC1815M0	Transistor	2SC1815 Y,GR			01
-304	IC1815M0	Transistor	2SC1815 Y,GR			01
Q305	IA101590	Transistor	2SA1015 O,Y			01
-308	IA101590	Transistor	2SA1015 O,Y			01
Q309	IC1815M0	Transistor	2SC1815 Y,GR			01
Q401	IC1815M0	Transistor	2SC1815 Y,GR			01
-404	IC1815M0	Transistor	2SC1815 Y,GR			01
Q405	IA101590	Transistor	2SA1015 O,Y			01
-408	IA101590	Transistor	2SA1015 O,Y			01
Q409	IC1815M0	Transistor	2SC1815 Y,GR			01
* SW101	V4584500	Slide Switch	SSSF142NA1			02
* SW102	V4584400	Slide Switch	SSSF122NA1			02
*	V5398100	Electrolytic Cap.	4.7 50.0V	C:111,112,211,212,311, 312,411,412		
	VZ353500	Ceramic Capacitor-SL	100P 50V J	C:104,105,204,205,304, 305,404,405		01
	VZ354000	Ceramic Capacitor-F	0.01 50V Z	C:107,307		01
	VZ354600	Monolithic Ceramic Cap.	0.1 50V Z	C:101-103,106,201-,203, 206,301-303,306, 401-403,406		01
	HF455100	Carbon Resistor	100.0 1/4 J	R:113,213,313,413		01
	HF456150	Carbon Resistor	1.5K 1/4 J	R:112,212,312,412		01
	HF457100	Carbon Resistor	10.0K 1/4 J	R:101-104,201-204, 301-304,401-404		01
	HF457120	Carbon Resistor	12.0K 1/4 J	R:111,211,311,411		01
	HF457470	Carbon Resistor	47.0K 1/4 J	R:107-110,207-210, 307-310,407-410		01
	HF458100	Carbon Resistor	100.0K 1/4 J	R:105,106,205,206,305, 306,405,406		01
*	AAX08980	Circuit Board	INJK	(XW206B0)		
CN601	--	Connector, FFC	52045 35P TE	(VQ04840)		

*: New Parts

RANK: Japan only

REF NO.	PART NO.	DESCRIPTION	REMARKS	QTY	RANK
CN602	--	Connector, FFC	52045 35P TE (VQ04840)		
JK101	VU805200	XLM Connector	XLR NC3FAV1-0	INPUT	04
-108	VU805200	XLM Connector	XLR NC3FAV1-0		04
JK109	V2954500	Phone Jack	LJ-0695-4R-A	INSERT I/O 0dB	02
-116	V2954500	Phone Jack	LJ-0695-4R-A		02
	VZ353500	Ceramic Capacitor-SL	100P 50V J	C:101-116	01
	HF455330	Carbon Resistor	330.0 1/4 J	R:101-108	01
*	AAX09000	Circuit Board	INPAN	(XW205B0)	
	VV291400	Jumper Wire	0.6		01
CN501	VP682200	Connector, FFC	52045 8P TE		01
CN502	VP127700	Connector, FFC	52045 24P TE		01
CN503	VP127700	Connector, FFC	52045 24P TE		01
CN504	VP682200	Connector, FFC	52045 8P TE		01
* VR101	V3820800	Rotary Variable Resistor	AC20K&TAC20K&T40K	PAN	
* -108	V3820800	Rotary Variable Resistor	AC20K&TAC20K&T40K		
*	AAX09080	Circuit Board	ISRT 1,6/6	(XW217B0)	
	AAX09090	Circuit Board	ISRT 2,3,4,5/6	(XW217B0)	
CN101	VP127700	Connector, FFC	52045 24P TE		01
CN102	VV066200	Connector Base Post	M2426XX 2P TE		01
CN103	VN394900	Connector, FFC	52045 14P TE		01
CN104	VV066800	Connector Base Post	M2426XX 8P TE		01
CN105	VV066600	Connector Base Post	M2426XX 6P TE		01
CN106	VV066700	Connector Base Post	M2426XX 7P TE		01
CN107	VV066400	Connector Base Post	M2426XX 4P TE		01
CN108	VV067000	Connector Base Post	M2426XX 10P TE		01
CN109	VV066900	Connector Base Post	M2426XX 9P TE		01
CN110	VV066500	Connector Base Post	M2426XX 5P TE		01
CN111	VV066300	Connector Base Post	M2426XX 3P TE		01
CN151	VV066400	Connector Base Post	M2426XX 4P TE		01
CN152	VV066300	Connector Base Post	M2426XX 3P TE		01
CN201	VV067000	Connector Base Post	M2426XX 10P TE		01
CN202	LB932040	Base Post Connector	VH- 4P TE		01
CN203	VV066800	Connector Base Post	M2426XX 8P TE		01
CN204	LB932040	Base Post Connector	VH- 4P TE		01
CN205	VV066700	Connector Base Post	M2426XX 7P TE		01
CN206	VV067200	Connector Base Post	M2426XX 12P TE		01
CN207	LB932040	Base Post Connector	VH- 4P TE		01
CN208	VV066800	Connector Base Post	M2426XX 8P TE		01
CN209	VQ046400	Connector, FFC	52044 35P SE		01
CN210	LB932040	Base Post Connector	VH- 4P TE		01
CN212	VV066700	Connector Base Post	M2426XX 7P TE		01
CN213	VV066500	Connector Base Post	M2426XX 5P TE		01
CN214	VV067100	Connector Base Post	M2426XX 11P TE		01
CN215	VV066600	Connector Base Post	M2426XX 6P TE		01
CN216	VV066500	Connector Base Post	M2426XX 5P TE		01
CN217	VV067000	Connector Base Post	M2426XX 10P TE		01
CN218	VV067100	Connector Base Post	M2426XX 11P TE		01
CN219	VV066500	Connector Base Post	M2426XX 5P TE		01
CN220	--	Connector Base Post	M2426XX 13P TE	(VV06730)	
CN221	VV066800	Connector Base Post	M2426XX 8P TE		01
CN222	VV066900	Connector Base Post	M2426XX 9P TE		01
CN223	VV066500	Connector Base Post	M2426XX 5P TE		01
CN224	VV066300	Connector Base Post	M2426XX 3P TE		01
CN225	VV066400	Connector Base Post	M2426XX 4P TE		01
CN227	VV066200	Connector Base Post	M2426XX 2P TE		01
CN228	--	Connector Assembly	1018&1018 4P 160L	(V527060)	
CN229	LB932020	Base Post Connector	VH- 2P TE		01
CN230	VZ005700	Fasten Terminal	TP82223-22		01
-233	VZ005700	Fasten Terminal	TP82223-22		01
CN234	VP127700	Connector, FFC	52045 24P TE		01
CN235	VN394900	Connector, FFC	52045 14P TE		01
CN236	--	Connector Assembly	2426&1018 8P 250L	(V440690)	
CN237	VV066200	Connector Base Post	M2426XX 2P TE		01
CN238	VV066400	Connector Base Post	M2426XX 4P TE		01
CN239	VV066200	Connector Base Post	M2426XX 2P TE		01
CN251	VV067000	Connector Base Post	M2426XX 10P TE		01
CN252	LB932020	Base Post Connector	VH- 2P TE		01
CN253	VV066600	Connector Base Post	M2426XX 6P TE		01

*: New Parts

RANK: Japan only

REF NO.	PART NO.	DESCRIPTION		REMARKS	QTY	RANK
CN254	LB932020	Base Post Connector	VH- 2P TE			01
CN255	VV066700	Connector Base Post	M2426XX 7P TE			01
CN256	VV067200	Connector Base Post	M2426XX 12P TE			01
CN257	LB932020	Base Post Connector	VH- 2P TE			01
CN258	VV066900	Connector Base Post	M2426XX 9P TE			01
CN301	VV067000	Connector Base Post	M2426XX 10P TE			01
CN302	LB932040	Base Post Connector	VH- 4P TE			01
CN303	VV066800	Connector Base Post	M2426XX 8P TE			01
CN304	LB932040	Base Post Connector	VH- 4P TE			01
CN305	VV066700	Connector Base Post	M2426XX 7P TE			01
CN306	VV067200	Connector Base Post	M2426XX 12P TE			01
CN307	LB932040	Base Post Connector	VH- 4P TE			01
CN308	VV066800	Connector Base Post	M2426XX 8P TE			01
CN309	VQ046400	Connector, FFC	52044 35P SE			01
CN310	LB932040	Base Post Connector	VH- 4P TE			01
CN312	VV067100	Connector Base Post	M2426XX 11P TE			01
CN313	VV066500	Connector Base Post	M2426XX 5P TE			01
CN314	VV066700	Connector Base Post	M2426XX 7P TE			01
CN315	VV066200	Connector Base Post	M2426XX 2P TE			01
CN401	VQ047500	Connector, FFC	52045 20P TE			01
-403	VQ047500	Connector, FFC	52045 20P TE			01
CN404	VV066800	Connector Base Post	M2426XX 8P TE			01
CN405	VV067200	Connector Base Post	M2426XX 12P TE			01
CN406	VV066900	Connector Base Post	M2426XX 9P TE			01
CN407	--	Connector Base Post	M2426XX 13P TE	(VV06730)		01
CN408	VV066200	Connector Base Post	M2426XX 2P TE			01
CN409	VV066600	Connector Base Post	M2426XX 6P TE			01
CN501	VQ045000	Connector, FFC	52044 20P SE			01
CN502	VQ047500	Connector, FFC	52045 20P TE			01
D101	VD631600	Diode	1SS133,176,HSS104			01
-108	VD631600	Diode	1SS133,176,HSS104			01
D201	VD631600	Diode	1SS133,176,HSS104			01
-05	VD631600	Diode	1SS133,176,HSS104			01
EM201	VV056900	Noice Filter	ZJSR5101-223TA			01
-203	VV056900	Noice Filter	ZJSR5101-223TA			01
F201	V2696300	Fuse	SIP 4A 125V J/U/C			01
-207	V2696300	Fuse	SIP 4A 125V J/U/C			01
IC101	XM356A00	IC	NJM2068L-D	OP AMP		02
-104	XM356A00	IC	NJM2068L-D	OP AMP		02
IC111	XM356A00	IC	NJM2068L-D	OP AMP		02
-115	XM356A00	IC	NJM2068L-D	OP AMP		02
IC121	XM356A00	IC	NJM2068L-D	OP AMP		02
-124	XM356A00	IC	NJM2068L-D	OP AMP		02
IC201	XM356A00	IC	NJM2068L-D	OP AMP		02
-217	XM356A00	IC	NJM2068L-D	OP AMP		02
IC601	XJ607A00	IC	NJM7805FA	REGULATOR +5V		02
JK101	VZ661000	Phone Jack	JY-6313	INSERT I/O 0dB		02
-122	VZ661000	Phone Jack	JY-6313	SUB IN +4dB		02
K101	--	Phone Jack Holder		(VZ70940)		
-111	--	Phone Jack Holder		(VZ70940)		
K201	V2402600	Terminal Angle Bracket				01
-204	V2402600	Terminal Angle Bracket				01
K301	V2402600	Terminal Angle Bracket				01
K302	V2402600	Terminal Angle Bracket				01
K401	VB966900	Style Pin	IMSA-6024			01
Q101	IA101590	Transistor	2SA1015 O,Y			01
Q201	IC1815M0	Transistor	2SC1815 Y,GR			01
Q202	IA101590	Transistor	2SA1015 O,Y			01
Q203	IC1815M0	Transistor	2SC1815 Y,GR			01
Q204	IA101590	Transistor	2SA1015 O,Y			01
-206	IA101590	Transistor	2SA1015 O,Y			01
RY101	VM640200	Relay	DC RY 12W-OH-K			05
-108	VM640200	Relay	DC RY 12W-OH-K			05
RY201	VM640200	Relay	DC RY 12W-OH-K			05
* SW401	V4584400	Slide Switch	SSSF122NA1			
	VV062800	Mylar Capacitor	0.1 50V J	C:365,366,368,370,601,602		01
	VZ352800	Ceramic Capacitor-SL	22P 50V J	C:242,245,250,253,258, 261,266,269,274,277, 282,285,290,293		01
	VZ353200	Ceramic Capacitor-SL	47P 50V J	C:103,110,115,122,127,		01

*: New Parts

RANK: Japan only

REF NO.	PART NO.	DESCRIPTION		REMARKS	QTY	RANK
	VZ353500	Ceramic Capacitor-SL	100P 50V J	127,134,139,146,151, 157,161,167,171,177, 181,187,191,202,205, 210,213,218,221,226, 229,302,305,310,313, 318,321,327,331,336, 340,343,402,405,408, 411,414,417,420,423 C:102,109,114,121,126, 133,138,145,150,156, 160,166,170,176,180, 186,190,401,404,407, 410,413,416,419,422		01
	VZ353600	Ceramic Cap.-B	220P 50V K	C:201,204,209,212,217, 220,225,228,241,244, 249,252,257,260,265, 268,273,276,281,284, 289,292,301,304,309, 312,317,320,326,330, 335,339,342		01
	VZ354000	Ceramic Capacitor-F	0.01 50V Z	C:105,106,117,118,129, 130,141,142,153,154, 163,164,173,174,183, 184,193,194,207,208, 215,216,223,224,231, 232,247,248,255,256, 263,264,271,272,279, 280,287,288,295,296, 307,308,315,316,323, 324,333,334,337,338, 345,346,353,425-432		01
	UJ639220	Electrolytic Cap.	2200 16.0V	C:369		02
	UJ659100	Electrolytic Cap.	1000 35.0V	C:361-364		02
	UJ838220	Electrolytic Cap.	220.00 16.0V	C:371-373		01
	UJ847100	Electrolytic Cap.	10.00 25.0V	C:351,352		01
	UJ847470	Electrolytic Cap.	47.00 25.0V	C:101,104,107,108, 111-113,116,119,120, 123-125,128,131,132, 135-137,140,143,144, 147-149,152,155,158, 159,162,165,168,169, 172,175,178,179,182, 185,188,189,192, 195-197,203,206,211, 214,219,222,227,230, 243,246,251,254,259, 262,267,270,275,278, 283,286,291,294,303, 306,311,314,319,322, 325,328,329,332,341, 344,403,406,409,412, 415,418,421,424		01
	UJ867470	Electrolytic Cap.	47.00 50.0V	C:367		01
	HF454100	Carbon Resistor	10.0 1/4 J	R:202,205,208,211,214, 217,220,223,232,235, 238,241,244,247,250, 253,256,259,262,265, 268,271,303,307,311, 314,317,320,327,334, 341,346,601-617,623, 626,629,632,635,638, 641,644		01
	HF456220	Carbon Resistor	2.2K 1/4 J	R:401		01
	HF456470	Carbon Resistor	4.7K 1/4 J	R:362,364-366,368,370-374		01
	HF457100	Carbon Resistor	10.0K 1/4 J	R:102,103,108,109,114, 115,120,121,126,127, 132,133,138,139,144, 145,150,151,154,155, 158,159,162,163,166, 167,170,171,174,175,		01

*: New Parts

RANK: Japan only

REF NO.	PART NO.	DESCRIPTION		REMARKS	QTY	RANK
				178,179,182,183,191, 192,361,367,377,378, 621,622,624,625,627, 628,630,631,633,634, 636,637,639,640,642, 643		
	HF457180	Carbon Resistor	18.0K 1/4 J	R:201,204,207,210,213, 216,219,222,225-227, 302,306,310,313,316, 319,323-326,330-333, 336-340,343-345		01
	HF457220	Carbon Resistor	22.0K 1/4 J	R:375		01
	HF457300	Carbon Resistor	30.0K 1/4 J	R:301,305,309		01
	HF457360	Carbon Resistor	36.0K 1/4 J	R:231,234,237,240,243, 246,249,252,255,258, 261,264,267,270,273-286		01
	HF457470	Carbon Resistor	47.0K 1/4 J	R:363,369,376,391		01
	HF458100	Carbon Resistor	100.0K 1/4 J	R:104,106,110,112,116, 118,122,124,128,130, 134,136,140,142,146, 148,152,156,160,164, 168,172,176,180,184, 195-197,315,318,321		01
	HF458220	Carbon Resistor	220.0K 1/4 J	R:101,105,107,111,113, 117,119,123,125,129, 131,135,137,141,143, 147,149,153,157,161, 165,169,173,177,181, 233,236,239,242,245, 248,304,308,312,322, 328,329,335,342,347		01
	HF458470	Carbon Resistor	470.0K 1/4 J	R:193,194,203,206,209, 212,215,218,221,224, 251,254,257,260,263, 266,269,272,501-516		01
*	V4314100	Circuit Board	MAS1	(XW212B0)		
*	V4467500	Push Button S	CD-GRAY/WHITE (A7/G1-A14/G8(ON))	SW101,201,301,401,501, 601,701,801	8	
*	V4469400	Push Button L	CL-GRAY/RED 102,202,302,402,502, 602,702,802 (A7/G1-A14/G8(AFL))	SW901(GROUP/AUX FLIP),	9	
	VV307300	LED Spacer				01
CN101	VV066900	Connector Base Post	M2426XX 9P TE			01
CN102	VV066800	Connector Base Post	M2426XX 8P TE			01
CN103	VV066300	Connector Base Post	M2426XX 3P TE			01
CN104	VV066200	Connector Base Post	M2426XX 2P TE			01
CN105	VV067000	Connector Base Post	M2426XX 10P TE			01
CN106	VP682200	Connector, FFC	52045 8P TE			01
CN107	--	Connector Base Post	M2426XX 13P TE	(VV06730)		
CN108	VV067000	Connector Base Post	M2426XX 10P TE			01
CN109	VV066500	Connector Base Post	M2426XX 5P TE			01
IC101	XM356A00	IC	NJM2068L-D	OP AMP		02
-103	XM356A00	IC	NJM2068L-D	OP AMP		02
IC301	XM356A00	IC	NJM2068L-D	OP AMP		02
-303	XM356A00	IC	NJM2068L-D	OP AMP		02
IC501	XM356A00	IC	NJM2068L-D	OP AMP		02
-503	XM356A00	IC	NJM2068L-D	OP AMP		02
IC701	XM356A00	IC	NJM2068L-D	OP AMP		02
-703	XM356A00	IC	NJM2068L-D	OP AMP		02
IC901	XF195A00	IC	NJM4580L	OP AMP		04
LD901	VV621000	LED	LT321-41-C13 GR	GROUP		01
LD902	VV938100	LED	LT331-41-C13 YE	AUX		01
LD903	VV620800	LED	LT311G-41-C13 RE	-48V		01
LD904	VV621000	LED	LT321-41-C13 GR	-12V,+15V,-15V		01
-906	VV621000	LED	LT321-41-C13 GR			01
SW101	VZ587700	Push Switch	2C-2S Lock	A7/G1(ON)		01
SW102	VZ251800	Push Switch	ESB68149	A7/G1(AFL)		03

*: New Parts

RANK: Japan only

REF NO.	PART NO.	DESCRIPTION		REMARKS	QTY	RANK
SW201	VZ587700	Push Switch	2C-2S Lock	A8/G2(ON)		01
SW202	VZ251800	Push Switch	ESB68149	A8/G2(AFL)		03
SW301	VZ587700	Push Switch	2C-2S Lock	A9/G3(ON)		01
SW302	VZ251800	Push Switch	ESB68149	A9/G3(AFL)		03
SW401	VZ587700	Push Switch	2C-2S Lock	A10/G4(ON)		01
SW402	VZ251800	Push Switch	ESB68149	A10/G4(AFL)		03
SW501	VZ587700	Push Switch	2C-2S Lock	A11/G5(ON)		01
SW502	VZ251800	Push Switch	ESB68149	A11/G5(AFL)		03
SW601	VZ587700	Push Switch	2C-2S Lock	A12/G6(ON)		01
SW602	VZ251800	Push Switch	ESB68149	A12/G6(AFL)		03
SW701	VZ587700	Push Switch	2C-2S Lock	A13/G7(ON)		01
SW702	VZ251800	Push Switch	ESB68149	A13/G7(AFL)		03
SW801	VZ587700	Push Switch	2C-2S Lock	A14/G8(ON)		01
SW802	VZ251800	Push Switch	ESB68149	A14/G8(AFL)		03
SW901	VZ587700	Push Switch	2C-2S Lock	GROUP/AUX FLIP		01
VR101	VU804600	Rotary Variable Resistor	A 20.0K RK09K113	SUBIN(L,R),G1/A7-G8/A14,		04
-114	VU804600	Rotary Variable Resistor	A 20.0K RK09K113	ST(L,R),MONO/C.LEVEL		04
VR201	VU804600	Rotary Variable Resistor	A 20.0K RK09K113	SUBIN(L,R),G1/A7-G8/A14,		04
-214	VU804600	Rotary Variable Resistor	A 20.0K RK09K113	ST(L,R),MONO/C.LEVEL		04
VR301	VU804600	Rotary Variable Resistor	A 20.0K RK09K113	SUBIN(L,R),G1/A7-G8/A14,		04
-314	VU804600	Rotary Variable Resistor	A 20.0K RK09K113	ST(L,R),MONO/C.LEVEL		04
VR401	VU804600	Rotary Variable Resistor	A 20.0K RK09K113	SUBIN(L,R),G1/A7-G8/A14,		04
-414	VU804600	Rotary Variable Resistor	A 20.0K RK09K113	ST(L,R),MONO/C.LEVEL		04
VR501	VU804600	Rotary Variable Resistor	A 20.0K RK09K113	SUBIN(L,R),G1/A7-G8/A14,		04
-514	VU804600	Rotary Variable Resistor	A 20.0K RK09K113	ST(L,R),MONO/C.LEVEL		04
VR601	VU804600	Rotary Variable Resistor	A 20.0K RK09K113	SUBIN(L,R),G1/A7-G8/A14,		04
-614	VU804600	Rotary Variable Resistor	A 20.0K RK09K113	ST(L,R),MONO/C.LEVEL		04
VR701	VU804600	Rotary Variable Resistor	A 20.0K RK09K113	SUBIN(L,R),G1/A7-G8/A14,		04
-714	VU804600	Rotary Variable Resistor	A 20.0K RK09K113	ST(L,R),MONO/C.LEVEL		04
VR801	VU804600	Rotary Variable Resistor	A 20.0K RK09K113	SUBIN(L,R),G1/A7-G8/A14,		04
-814	VU804600	Rotary Variable Resistor	A 20.0K RK09K113	ST(L,R),MONO/C.LEVEL		04
ZD901	VG443700	Zener Diode	MTZ J 33.0B 33.0V			01
	VZ353200	Ceramic Capacitor-SL	47P 50V J	C:102-104,202-204, 302-304,402-404, 502-504,602-604, 702-704,802-804, 903-908		01
	VZ353400	Ceramic Capacitor-SL	68P 50V J	C:109,209,309,409,509, 609,709,809		01
	VZ353500	Ceramic Capacitor-SL	100P 50V J	C:107,108,207,208,307, 308,407,408,507,508, 607,608,707,708,807, 808		01
	VZ353600	Ceramic Cap.-B	220P 50V K	C:101,201,301,401,501, 604,701,801		01
	VZ353900	Ceramic Cap.-B	1000P 50V K	C:111,112,211,311,312, 411,511,512,611,711, 712,811,913		01
	VZ354000	Ceramic Capacitor-F	0.01 50V Z	C:113-116,313-316, 513-516,713-716, 911,912		01
	UJ847100	Electrolytic Cap.	10.00 25.0V	C:106,206,306,406,506, 606,706,806,901,902		01
	UJ847470	Electrolytic Cap.	47.00 25.0V	C:105,110,205,210,305, 310,405,410,505,510, 605,610,705,710,805, 810,909,910		01
	HF454100	Carbon Resistor	10.0 1/4 J	R:123,223,323,423,523, 623,723,823,909,910		01
	HF454470	Carbon Resistor	47.0 1/4 J	R:117,217,317,417,517, 617,717,817		01
	HF455100	Carbon Resistor	100.0 1/4 J	R:125,225,325,425,525, 625,725,825		01
	HF455220	Carbon Resistor	220.0 1/4 J	R:118,120,218,220,318, 320,418,420,518,520, 618,620,718,720,818, 820		01
	HF456180	Carbon Resistor	1.8K 1/4 J	R:913,914,916		01
	HF456200	Carbon Resistor	2.0K 1/4 J	R:917,918		01
	HF456220	Carbon Resistor	2.2K 1/4 J	R:915		01

*: New Parts

RANK: Japan only

REF NO.	PART NO.	DESCRIPTION		REMARKS	QTY	RANK
	HF457100	Carbon Resistor	10.0K 1/4 J	R:121,122,221,222,321, 322,421,422,521,522, 621,622,721,722,821, 822,903,904,907,908		01
	HF457150	Carbon Resistor	15.0K 1/4 J	R:115,116,215,216,315, 316,415,416,515,516, 615,616,715,716,815, 816		01
	HF457160	Carbon Resistor	16.0K 1/4 J	R:901,902,905,906		01
	HF457180	Carbon Resistor	18.0K 1/4 J	R:101-114,119,126,127, 201-214,219,226,227, 301-314,319,326,327, 401-414,419,426,427, 501-514,519,526,527, 601-614,619,626,627, 701-714,719,726,727, 801-814,819,826,827		01
	HF458100	Carbon Resistor	100.0K 1/4 J	R:124,224,324,424,524, 624,724,824,911,912		01
*	V4314200	Circuit Board	MAS2	(XW213B0)		
*	V4467500	Push Button S	CD-GRAY/WHITE	SW151,251,351,451,551, 651,751,851 (A7/G1-A14/G8(ON)) SW906(OSCILLATOR(ON)), SW909(AUX7-10),910(AUX11- 14),913(MASTER PFL), 914(MONITOR(L+R))	13	
*	V4467800	Push Button S	MX-BLUE/WHITE	SW907(AUX1-2),908(AUX3-6)	2	
*	V4468000	Push Button S	RED/WHITE	SW911(ST)		
*	V4468200	Push Button S	YELLOW/WHITE	SW912(MONO/C)		
*	V4469300	Push Button L	CD-GRAY/WHITE	SW101(AUX1(ON)),201(AUX2 (ON)),301(AUX3(ON)), 401(AUX4(ON)),501(AUX5 (ON)),601(AUX6(ON)), 901(TALKBACK(ON))	7	
*	V4469400	Push Button L	CL-GRAY/RED	SW102(AUX1(AFL)),202(AUX2 (AFL)),302(AUX3(AFL)), 402(AUX4(AFL)),502(AUX5 (AFL)),602(AUX6(AFL)), 152(A7/G1(AFL)),252(A8/ G2(AFL)),352(A9/G3 (AFL)),452(A10/G4 (AFL)),552(A11/G5(AFL)), 652(A12/G6(AFL)),752 (A13/G7(AFL)),852 (A14/G8(AFL))	14	
	VV307300	LED Spacer				01
	VZ968500	Button S	NO.947 CD-GRAY	SW902-905(OSCILLATOR(PINK, 100Hz,1kHz,10kHz)), 915(MASTER SELECT (G1-8/A7-14)),917(MASTER SELECT(A7-14/G1-8)), 918(MASTER SELECT (MATRIX))	7	01
	V2947200	Button S	MX-BLUE	SW916(AUX1-6)		01
CN201	VP682200	Connector, FFC	52045 8P TE			01
CN202	VV066600	Connector Base Post	M2426XX 6P TE			01
CN203	VV066700	Connector Base Post	M2426XX 7P TE			01
CN204	VV066500	Connector Base Post	M2426XX 5P TE			01
CN205	VV066800	Connector Base Post	M2426XX 8P TE			01
-207	VV066800	Connector Base Post	M2426XX 8P TE			01
CN208	VV066900	Connector Base Post	M2426XX 9P TE			01
CN209	VV067100	Connector Base Post	M2426XX 11P TE			01
CN210	VV066500	Connector Base Post	M2426XX 5P TE			01
CN211	VV066200	Connector Base Post	M2426XX 2P TE			01
CN212	VV066400	Connector Base Post	M2426XX 4P TE			01
CN213	VV066300	Connector Base Post	M2426XX 3P TE			01
CN214	VV066700	Connector Base Post	M2426XX 7P TE			01
CN215	VV067000	Connector Base Post	M2426XX 10P TE			01

*: New Parts

RANK: Japan only

■ **M2500 OVERALL CIRCUIT DIAGRAM CONTENTS <P.1>**
BLOCK & LEVEL DIAGRAM
WIRING

P.1	...	CONTENTS
P.2	...	BLOCK & LEVEL DIAGRAM
P.3	...	OVERALL CIRCUIT DIAGRAM (IN1, IN2, INJK)
P.4	...	OVERALL CIRCUIT DIAGRAM (IN3)
P.5	...	OVERALL CIRCUIT DIAGRAM (IN4, INPAN, METER, CTRL 1/5, 2/5, 3/5, 4/5, 5/5)
P.6	...	OVERALL CIRCUIT DIAGRAM (ST1, ST2)
P.7	...	OVERALL CIRCUIT DIAGRAM (ST3, ST4, STJK)
P.8	...	OVERALL CIRCUIT DIAGRAM (MAS1 1/2, MAS1 2/2, MAS4)
P.9	...	OVERALL CIRCUIT DIAGRAM (MAS2)
P.10	...	OVERALL CIRCUIT DIAGRAM (MAS3, MASPAN)
P.11	...	OVERALL CIRCUIT DIAGRAM (ISRT 1/6, 2/6, 3/6, 4/6, 5/6, 6/6, MASOUT)
P.12	...	WIRING

- (マ): Mylar Capacitor
- (セ): Ceramic Capacitor
- (F): Metal Film Resistor
- (フ): Flame Proof C. Resistor

Note : See parts list for details of circuit board component parts.

■M2500 BLOCK & LEVEL DIAGRAM <P.2>

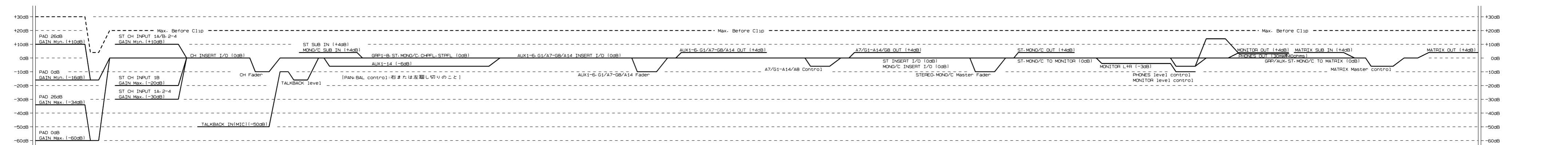
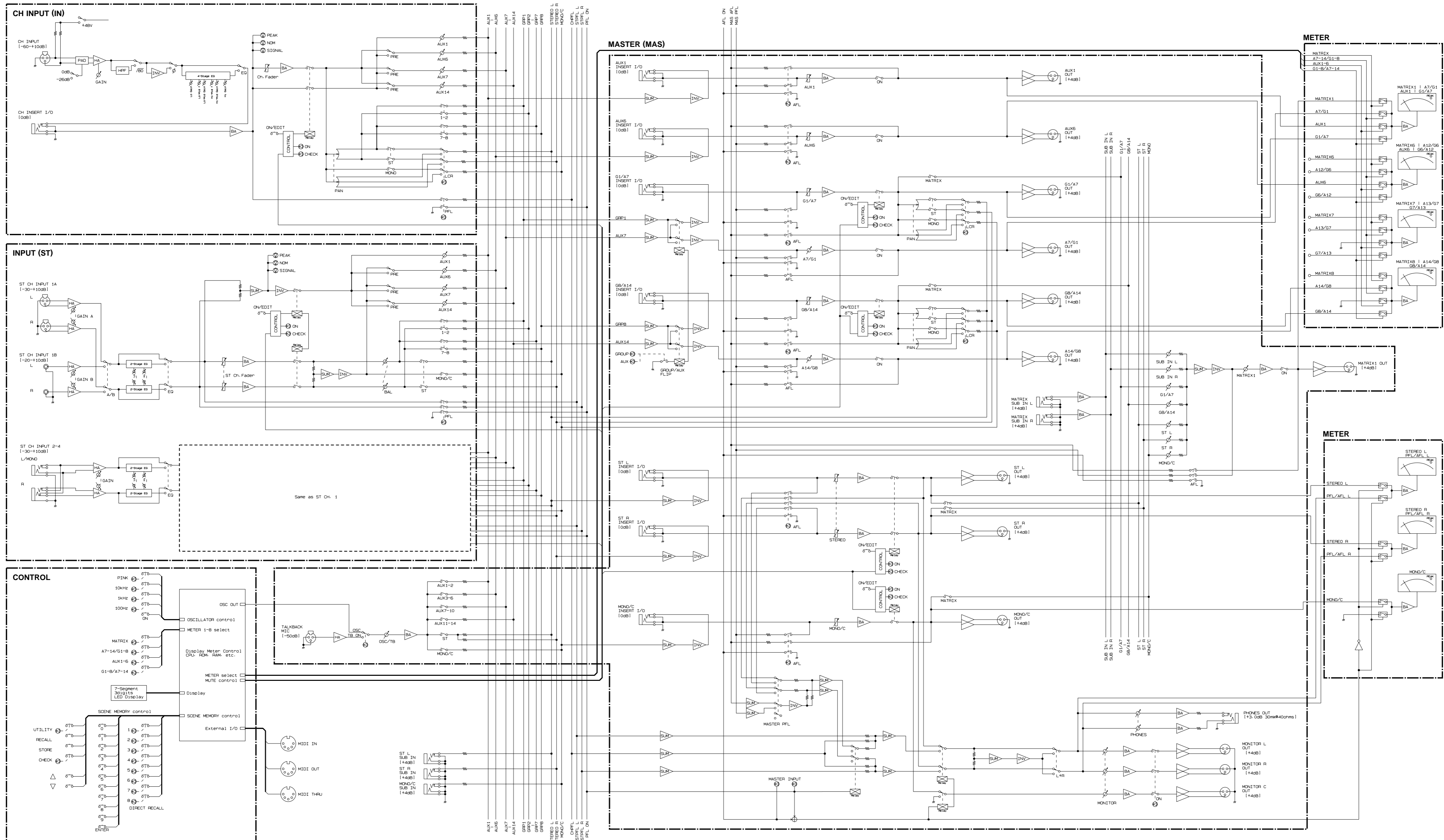

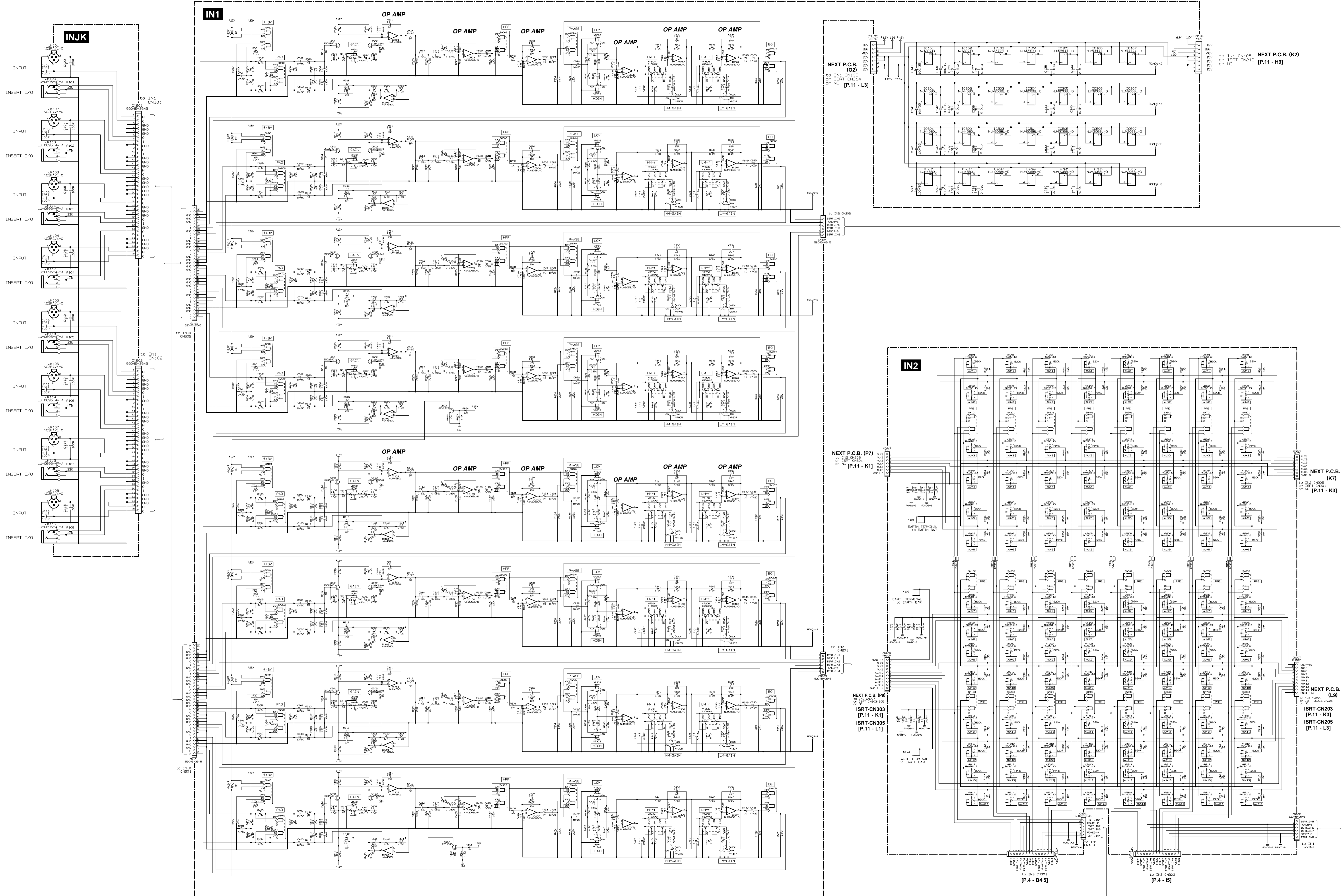

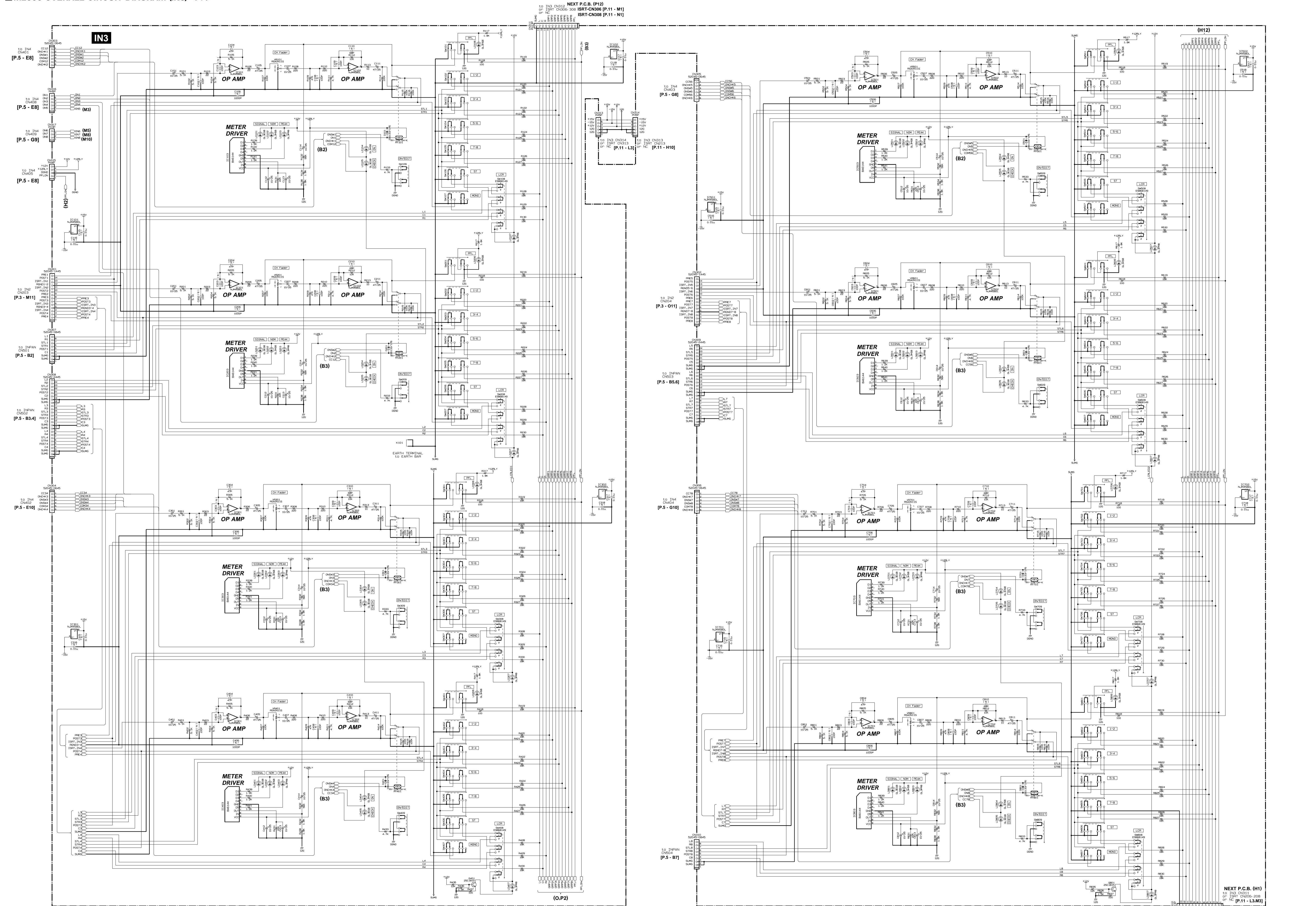

NEXT P.C.B. (H1)
TO IN3 CH211
OR ISRT-CN306-208
OF PCB P.11-L3.M3

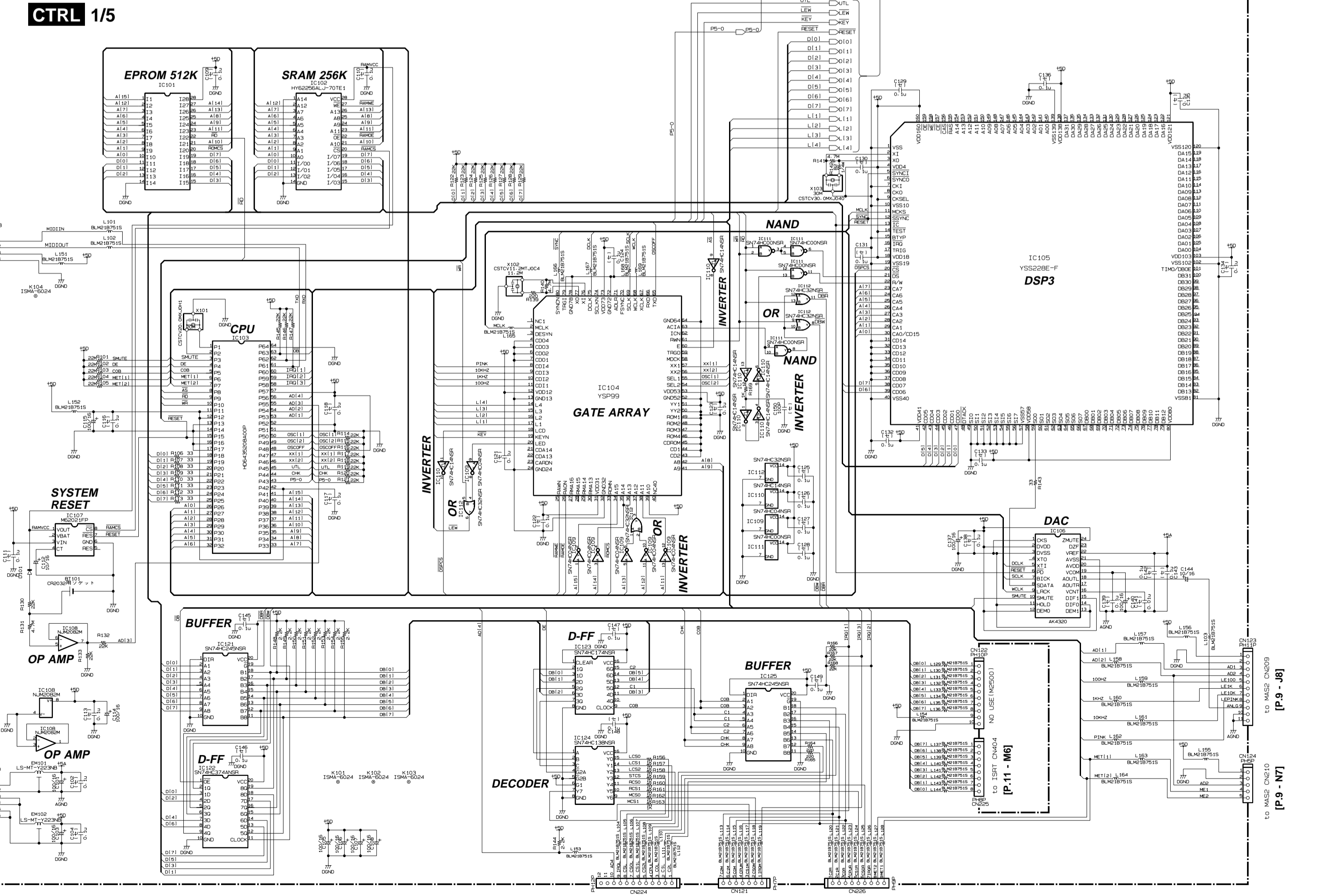
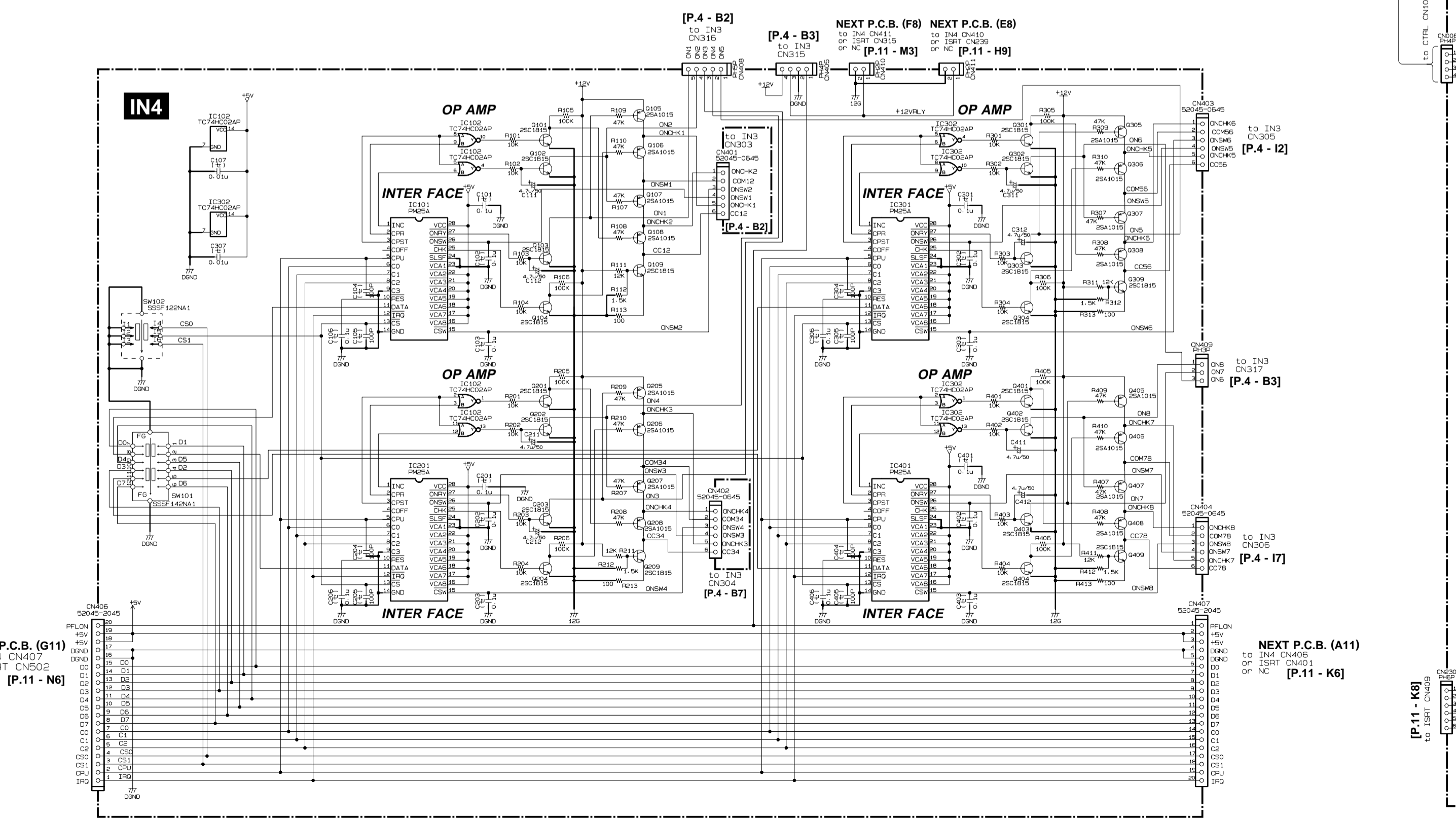
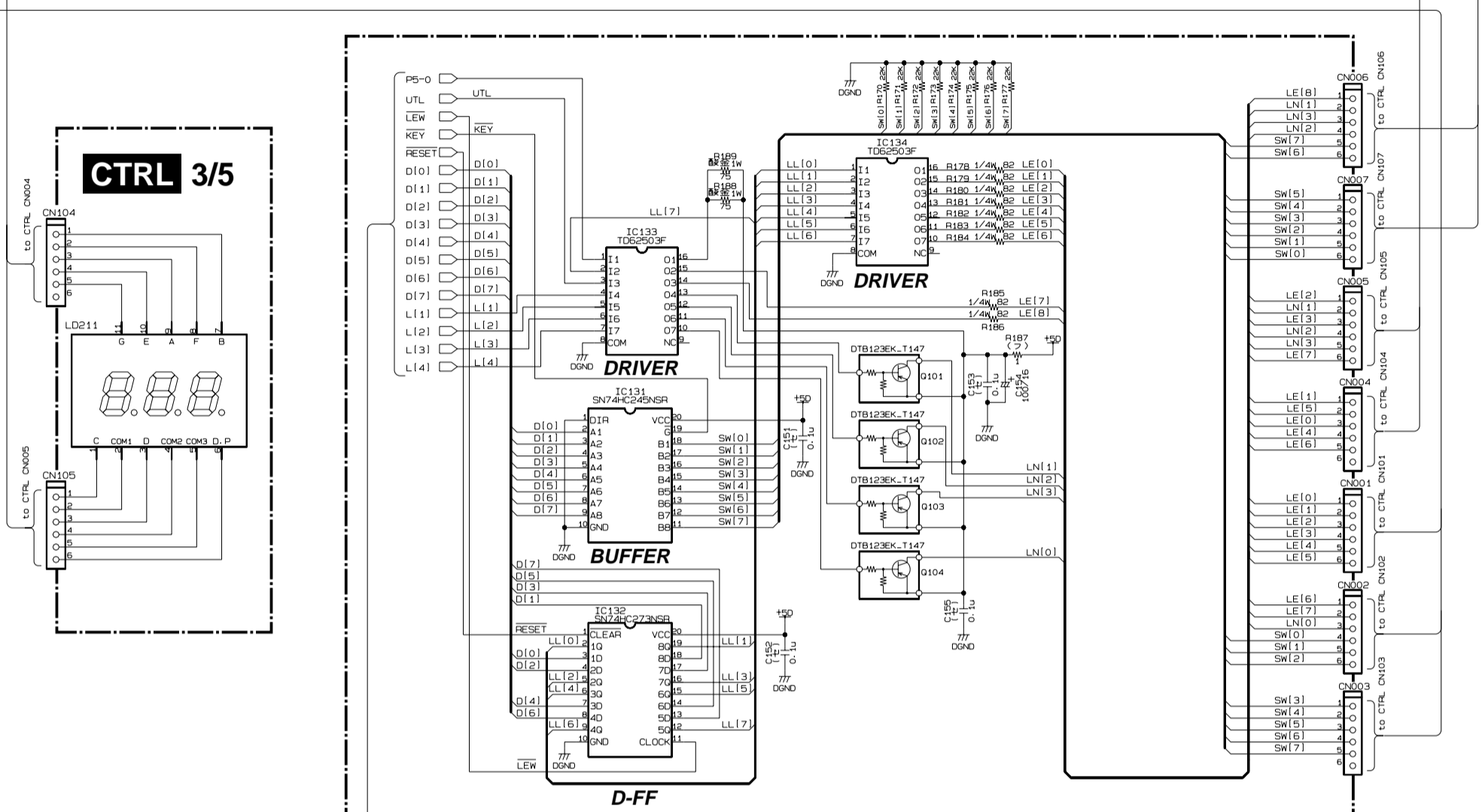
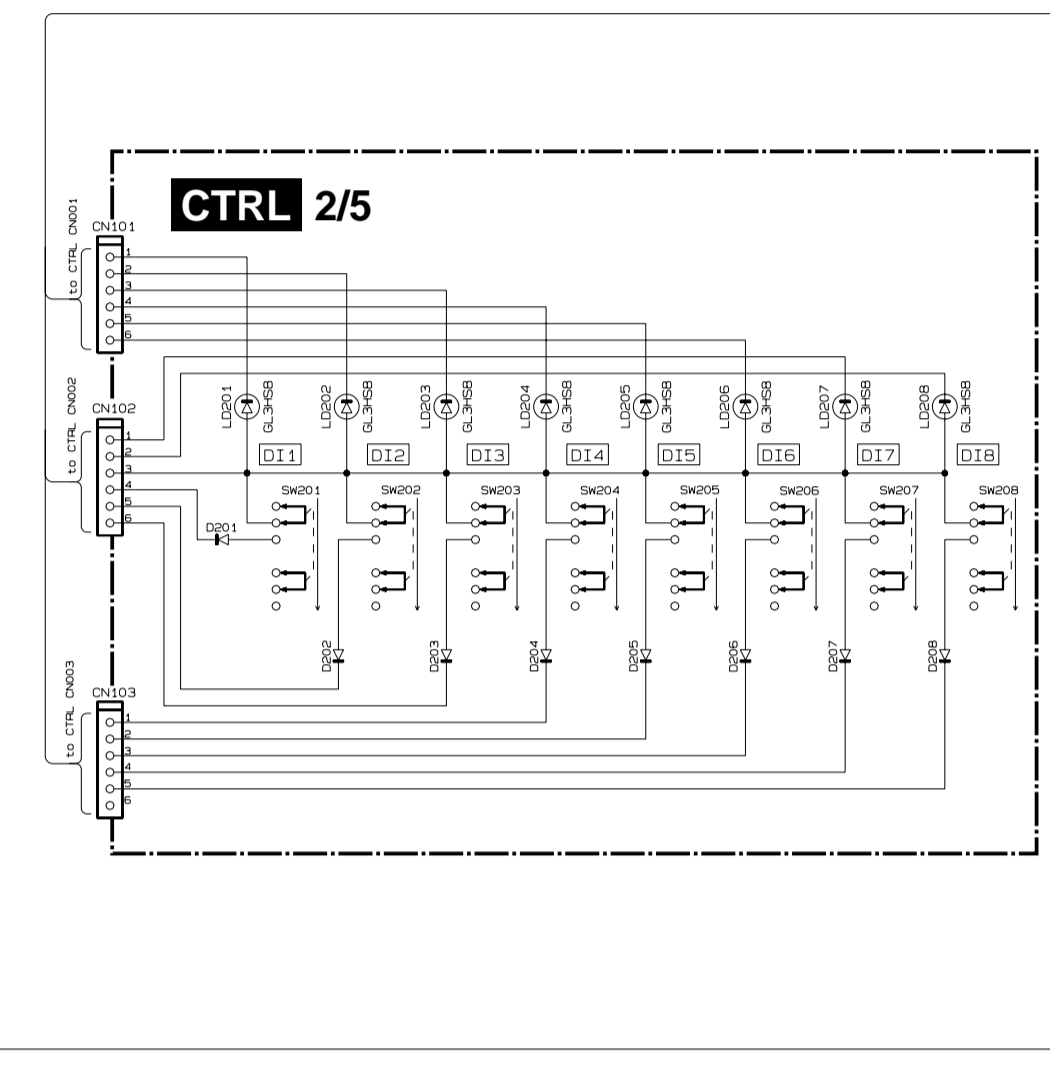
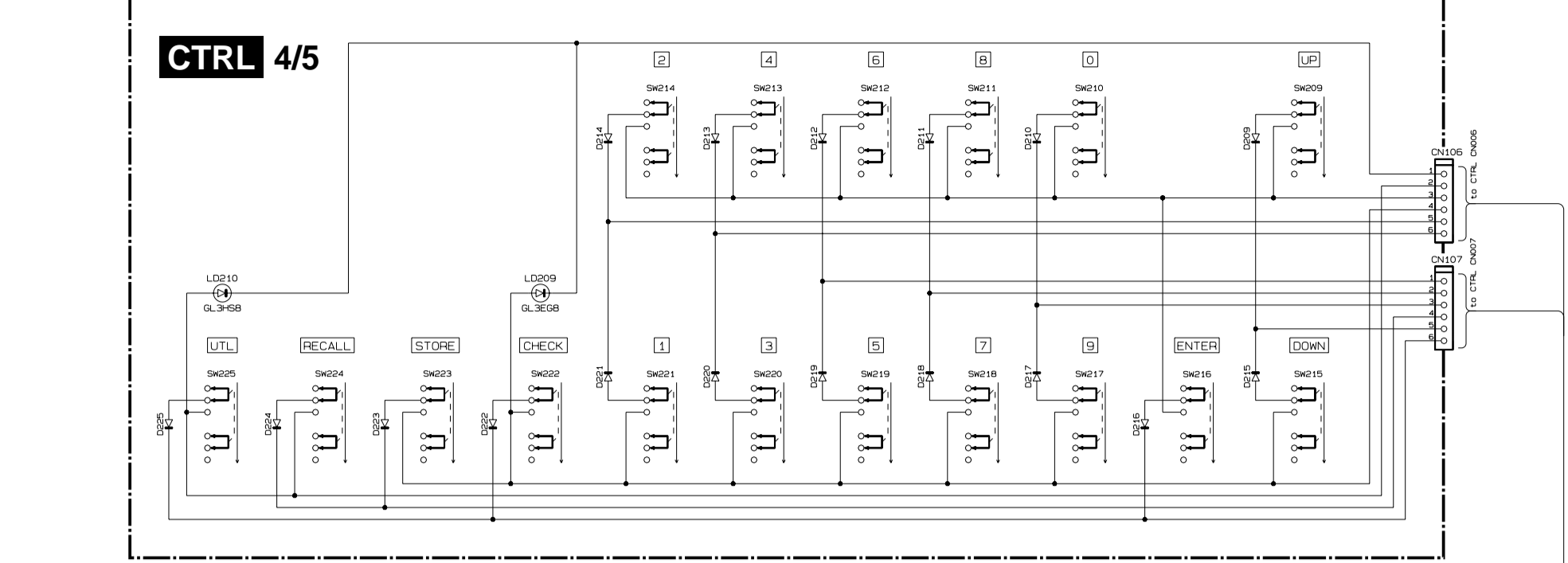
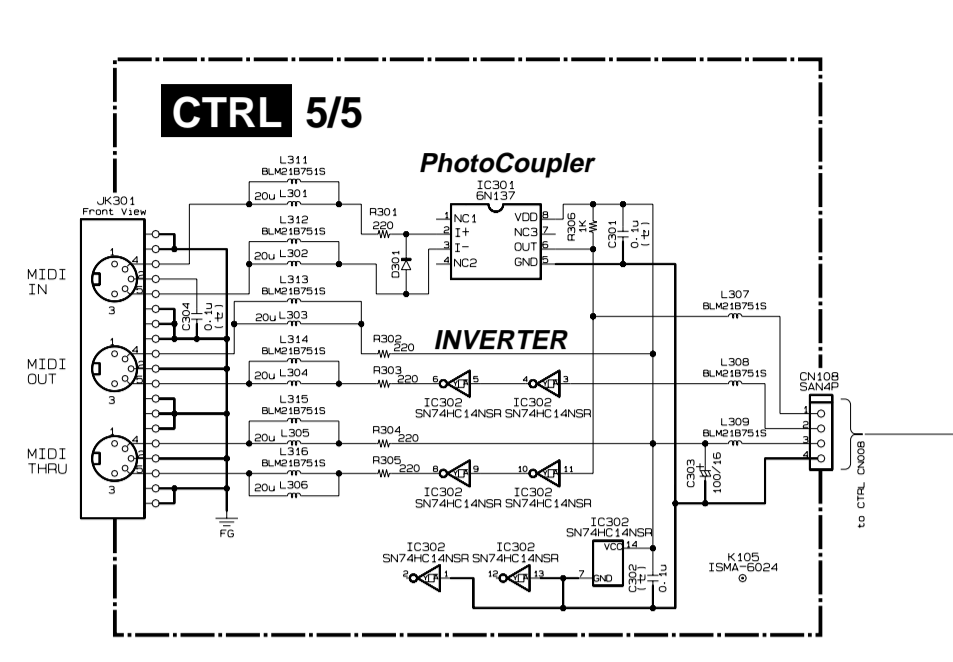
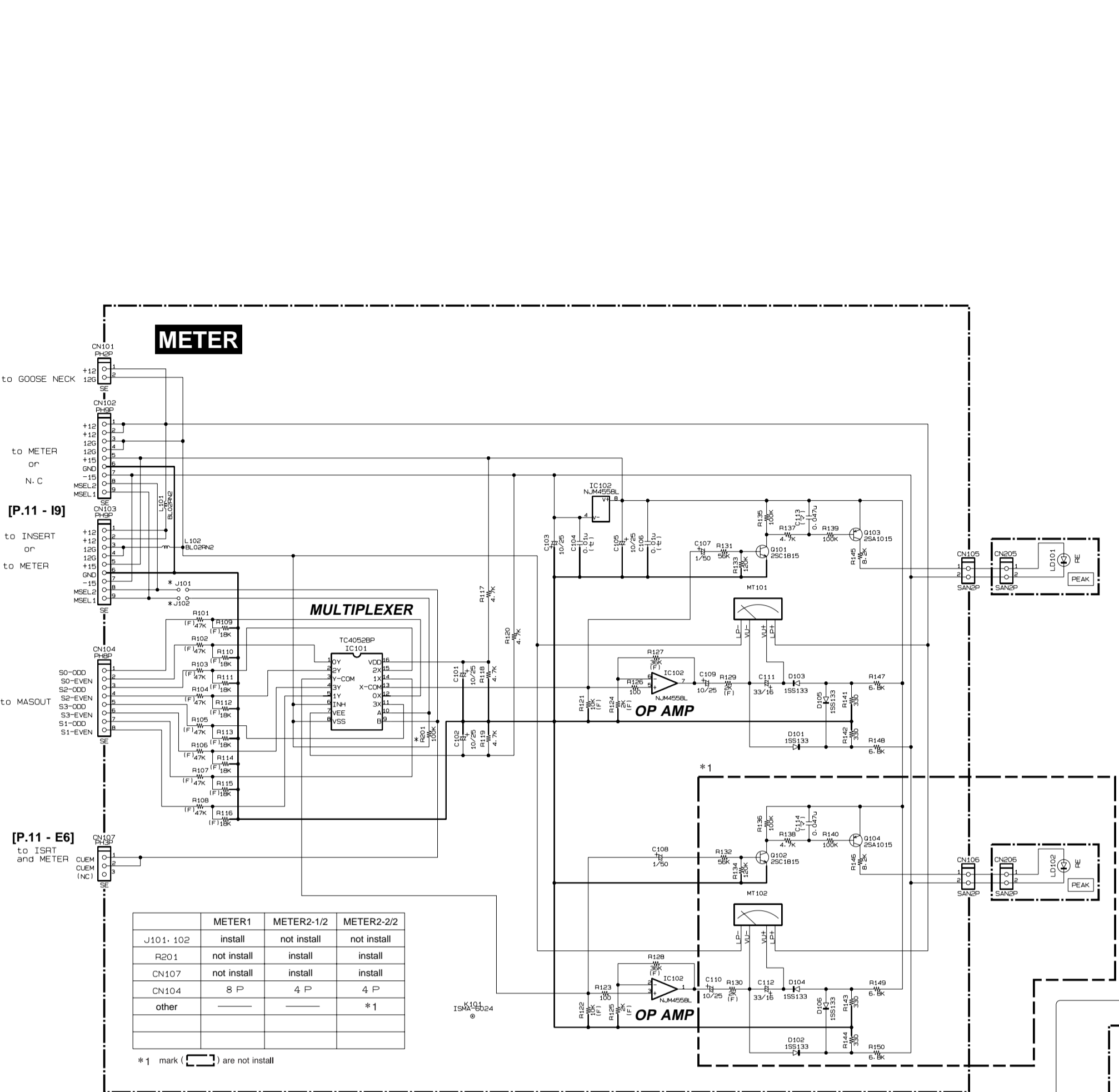
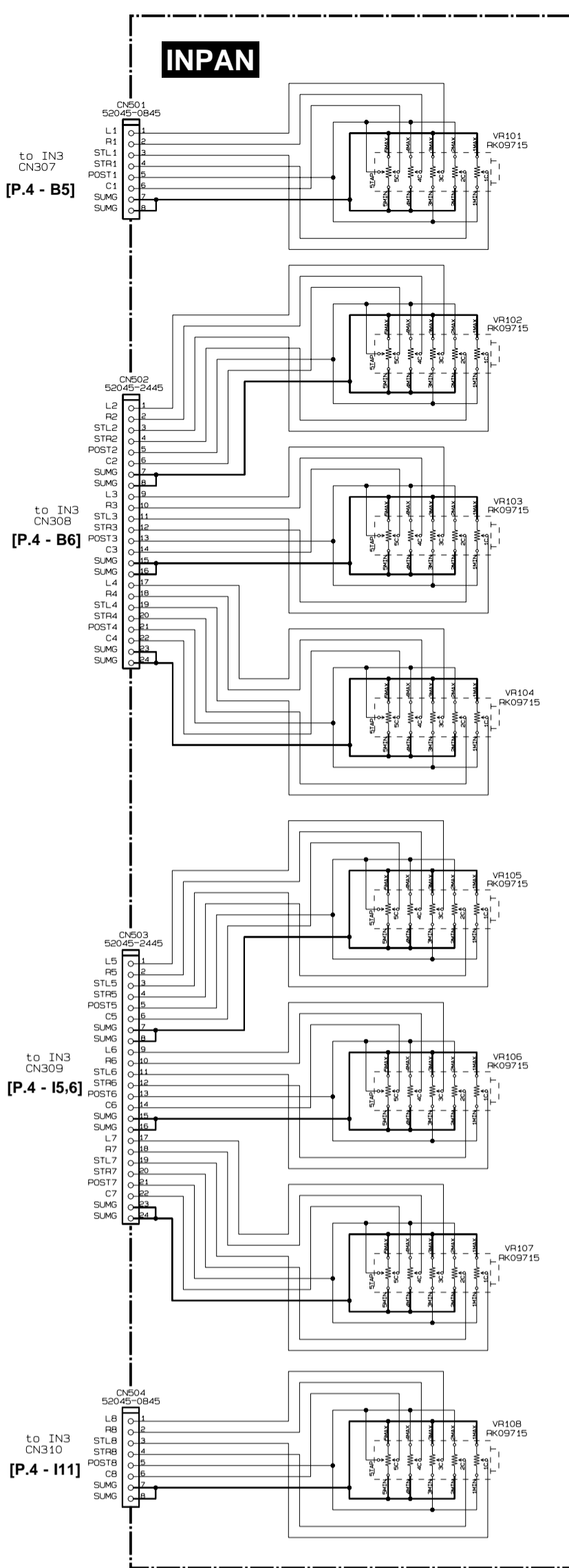

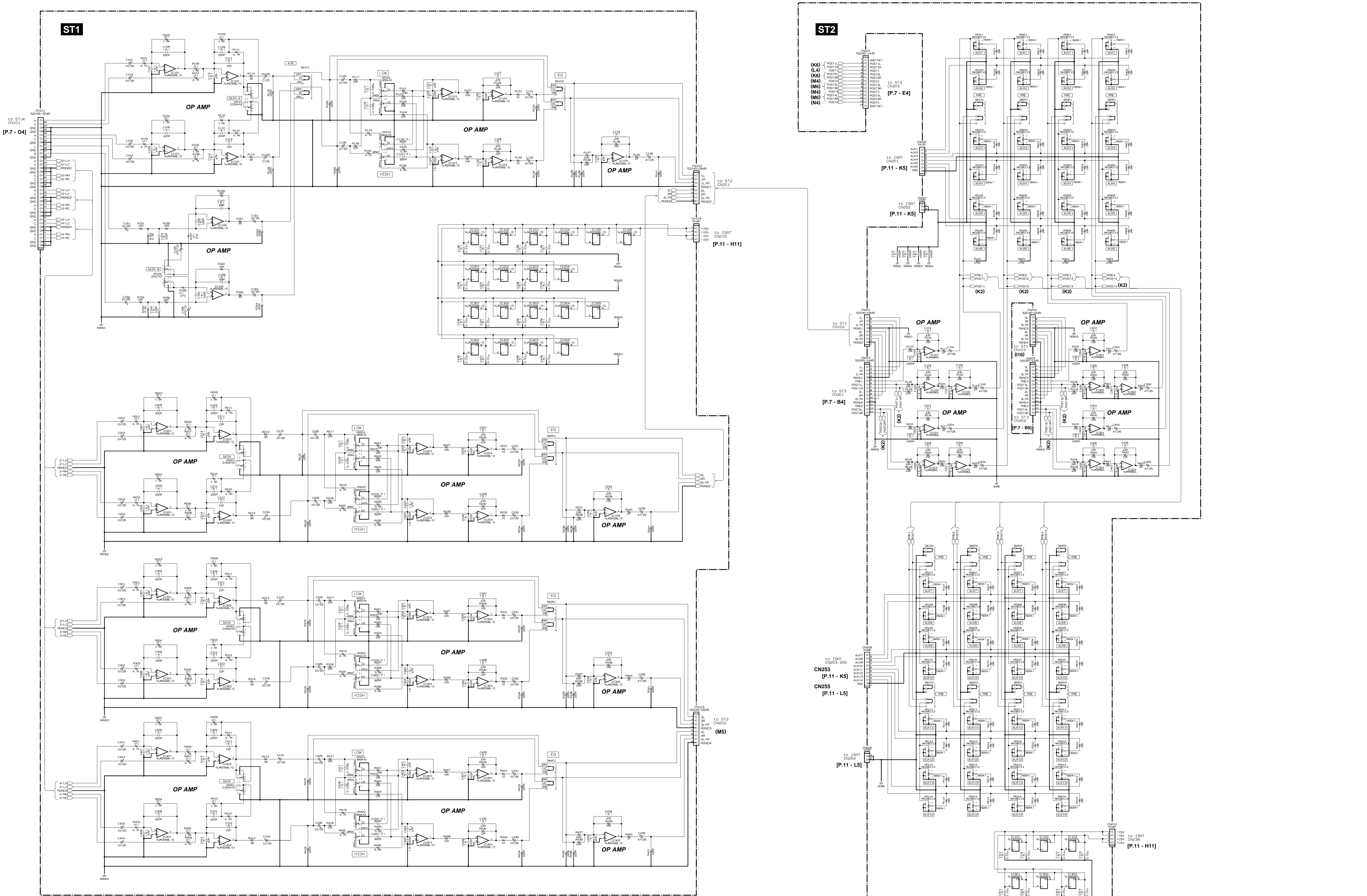

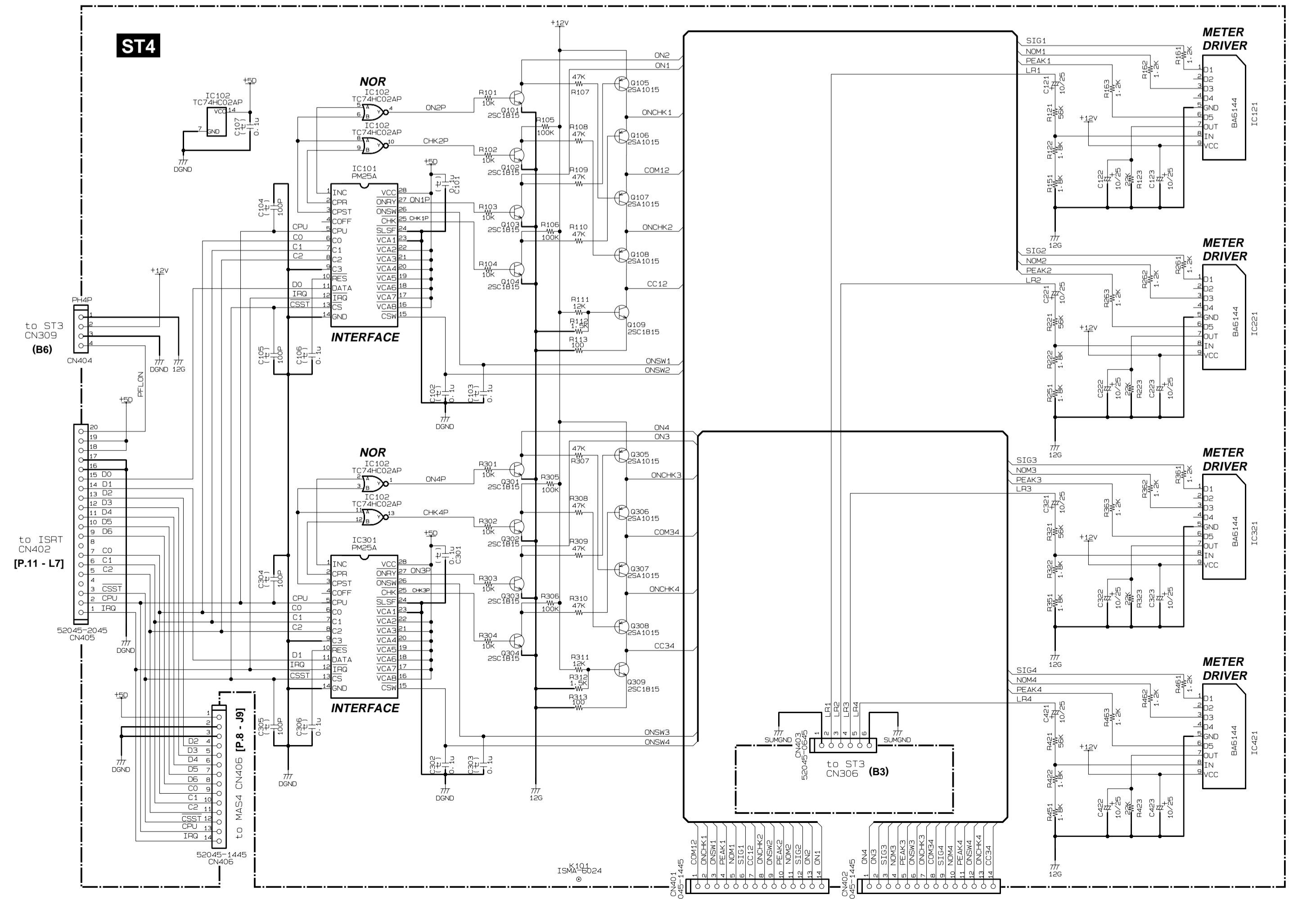
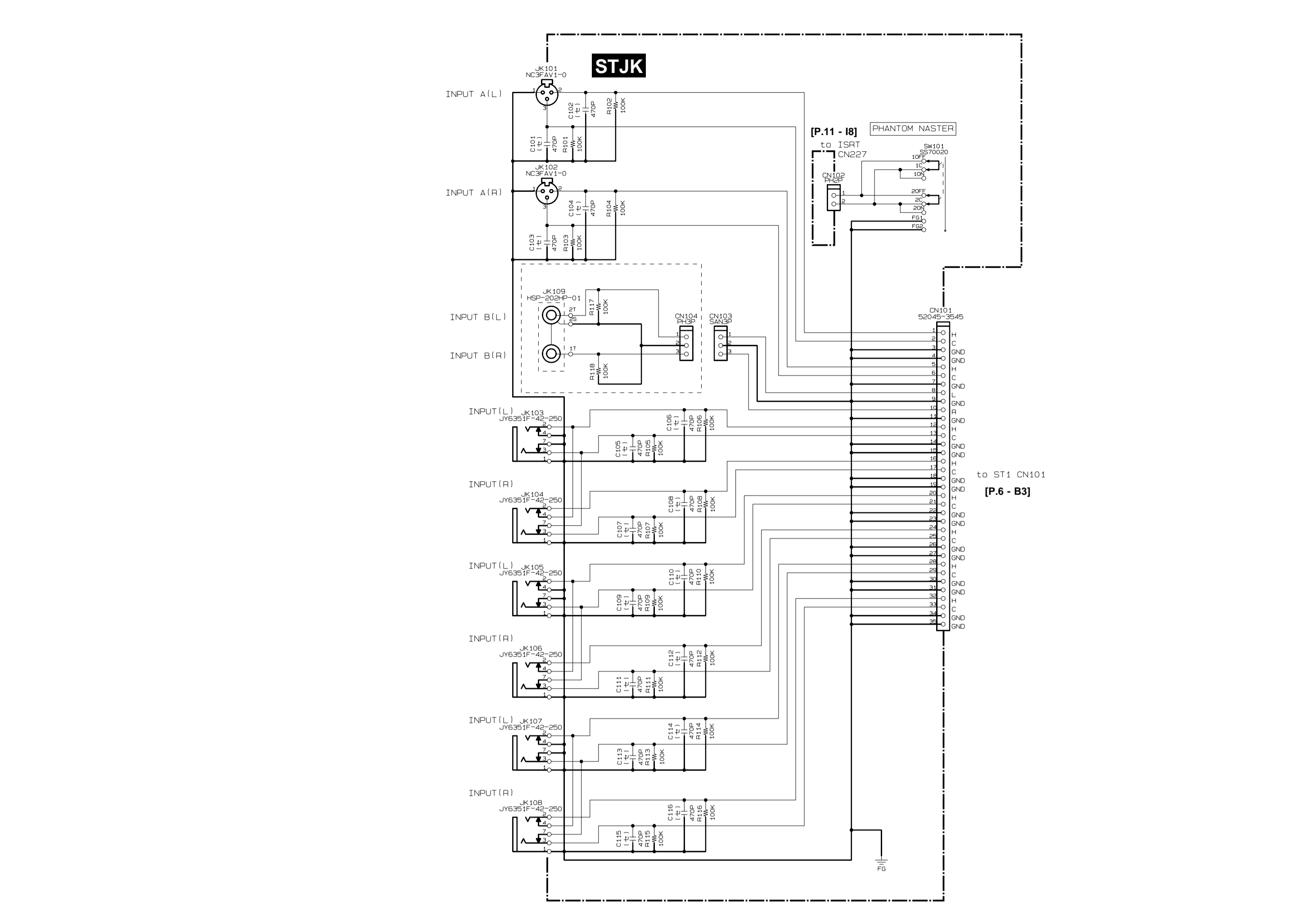
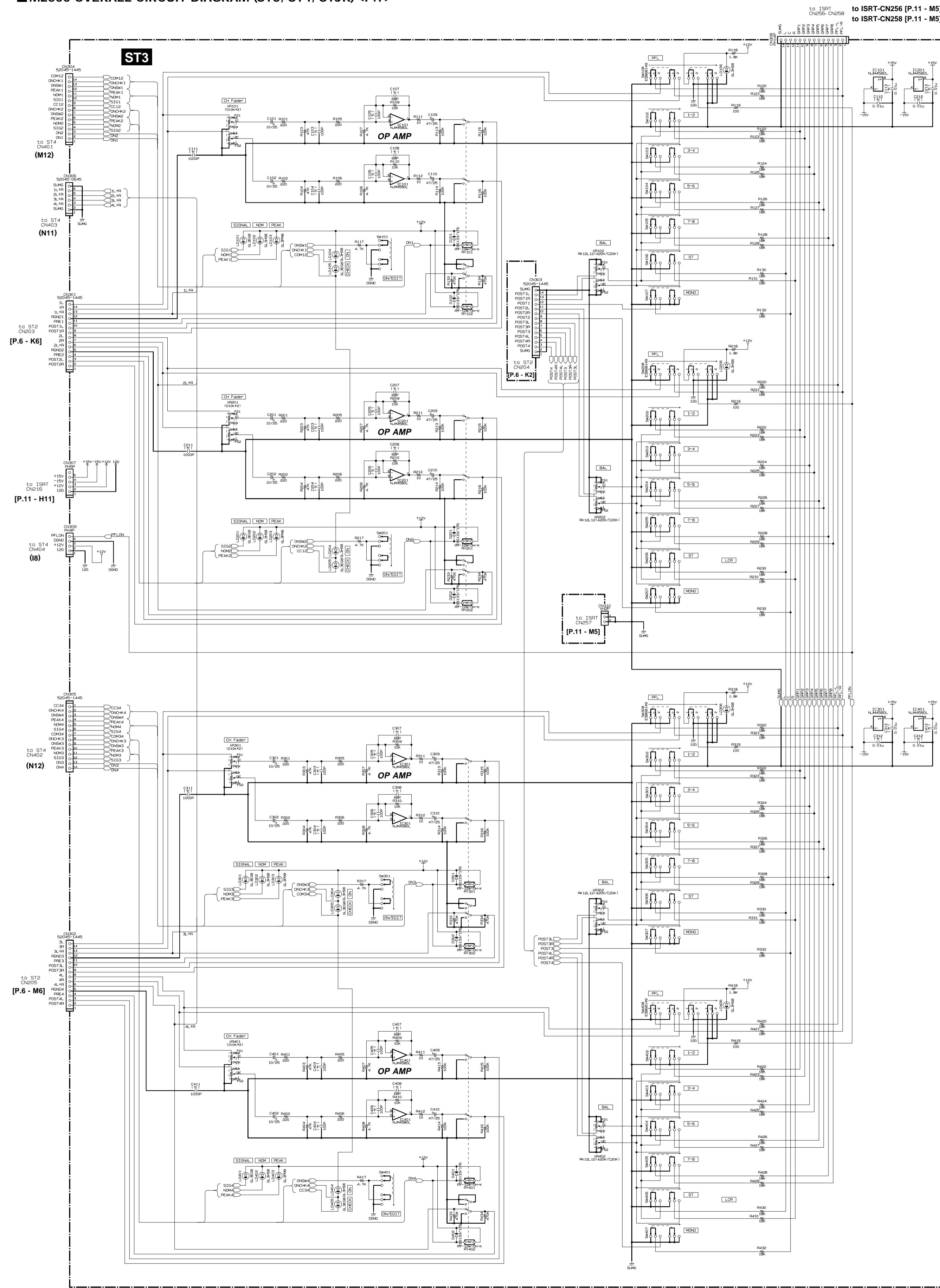

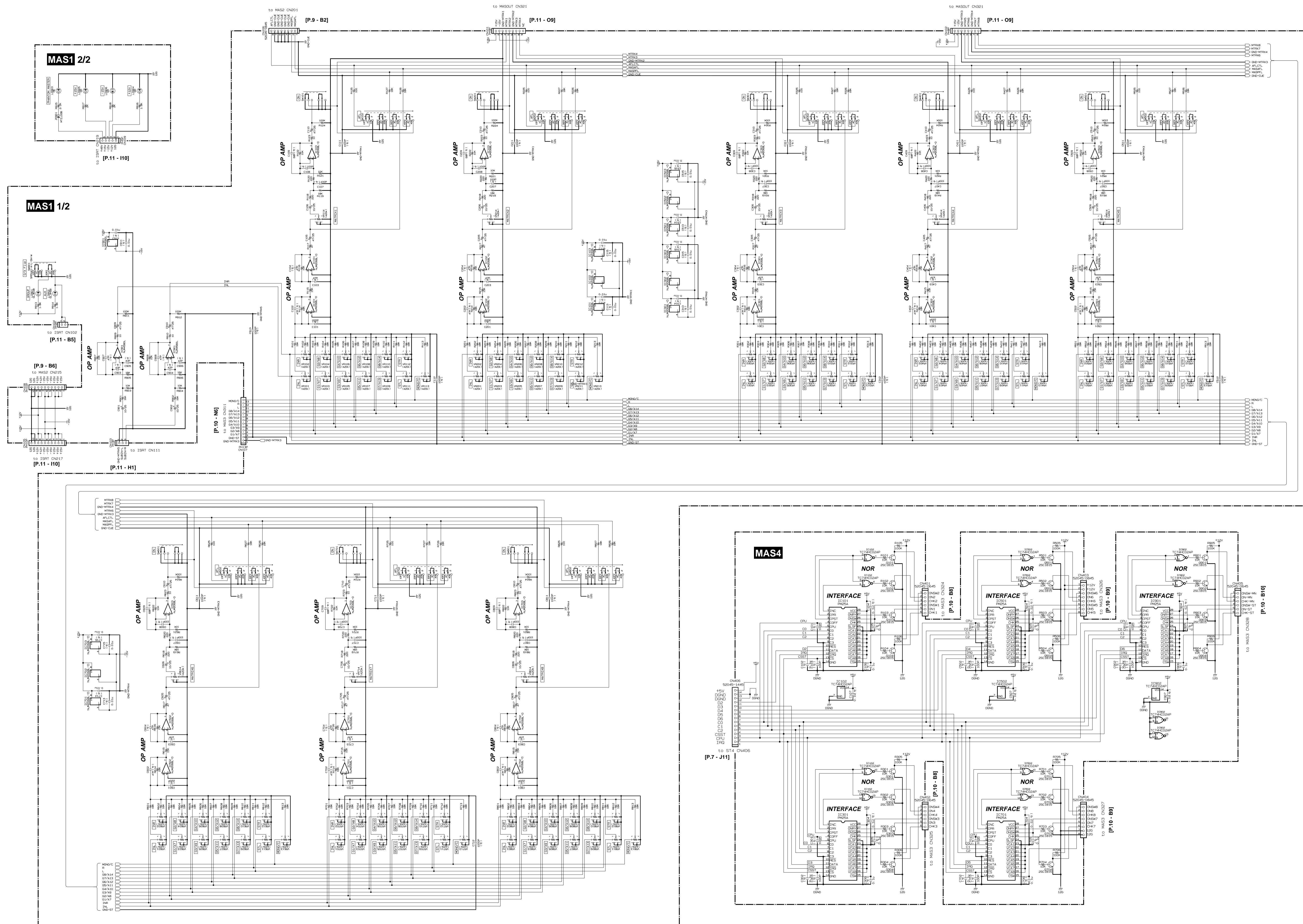

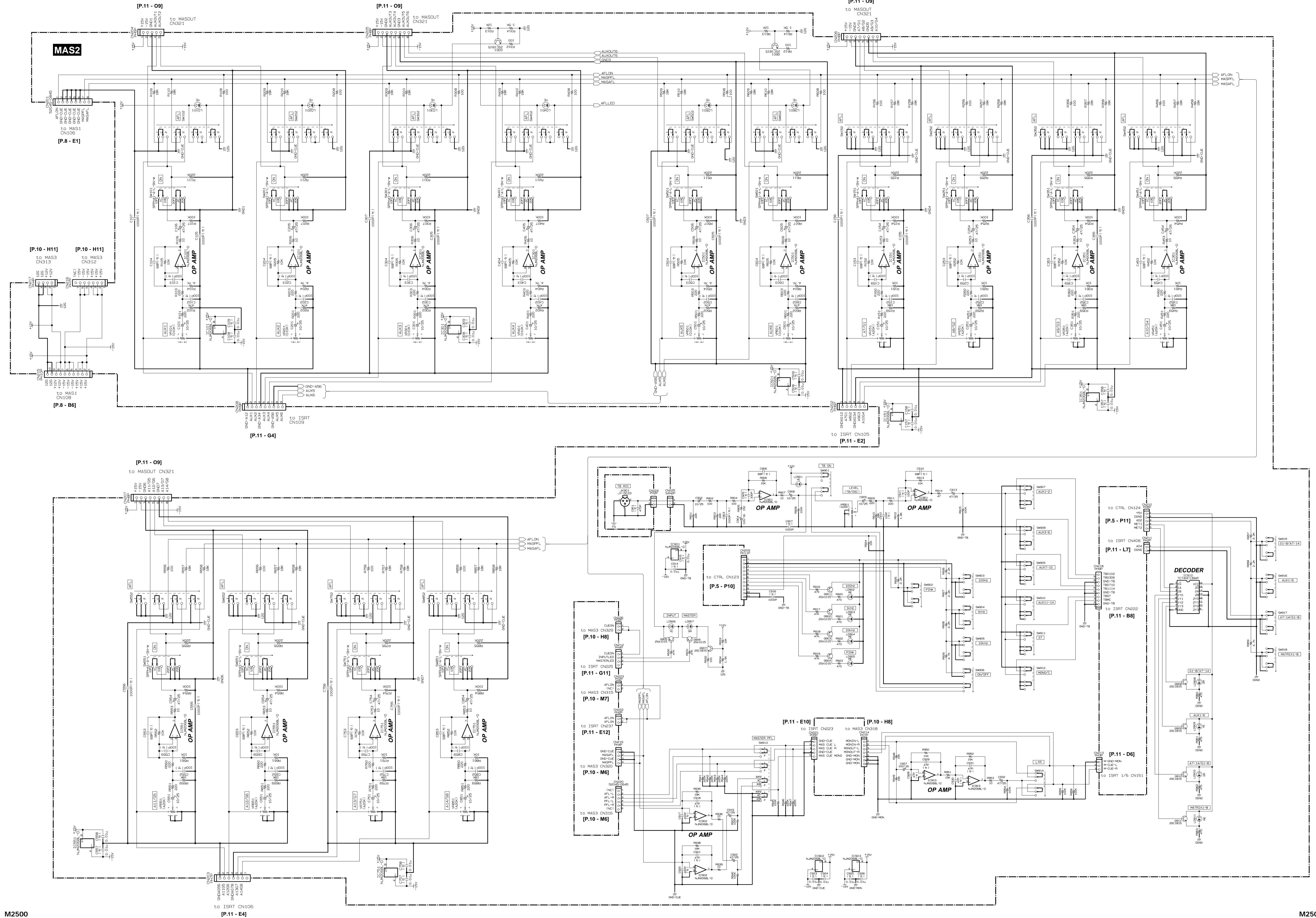

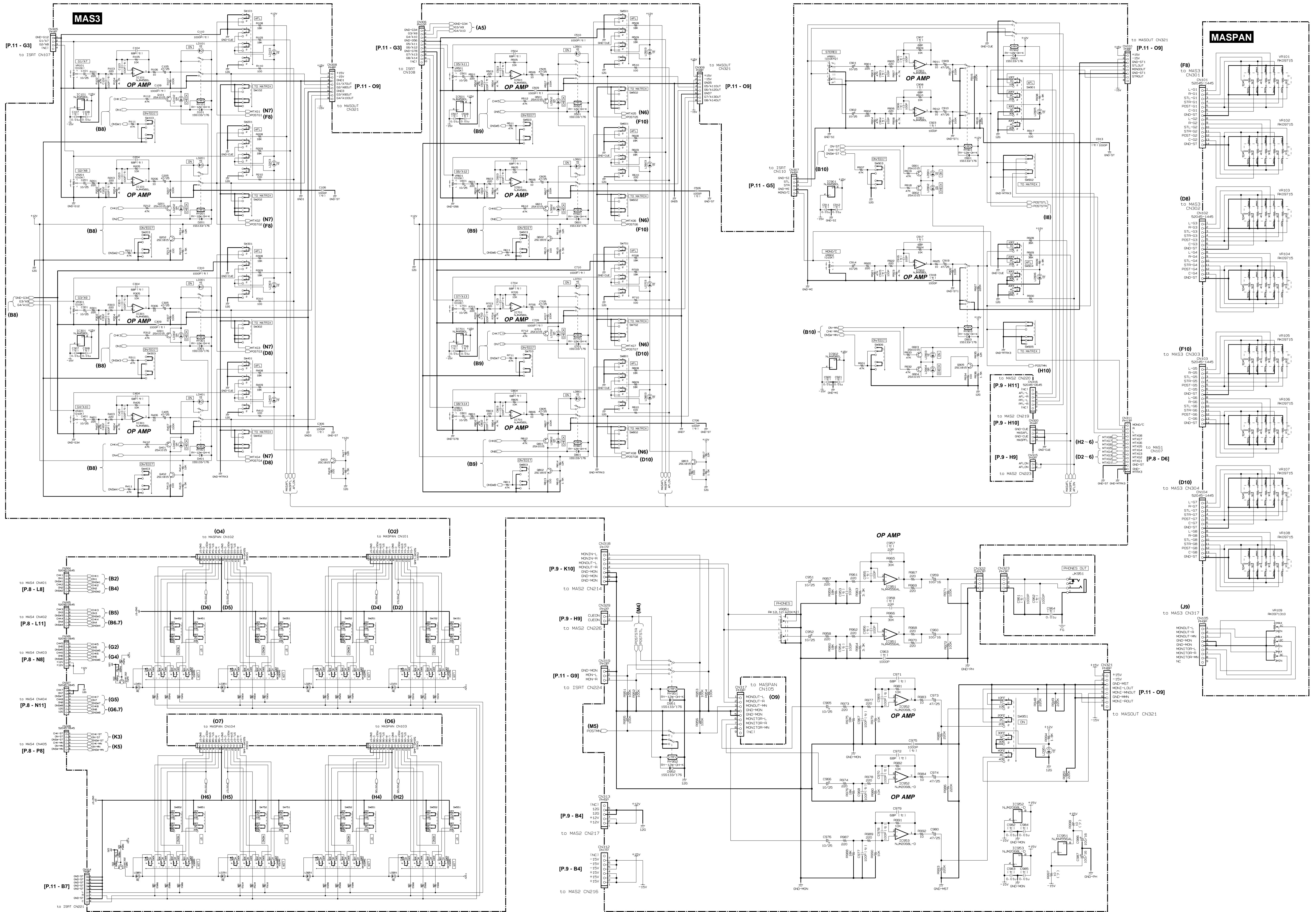

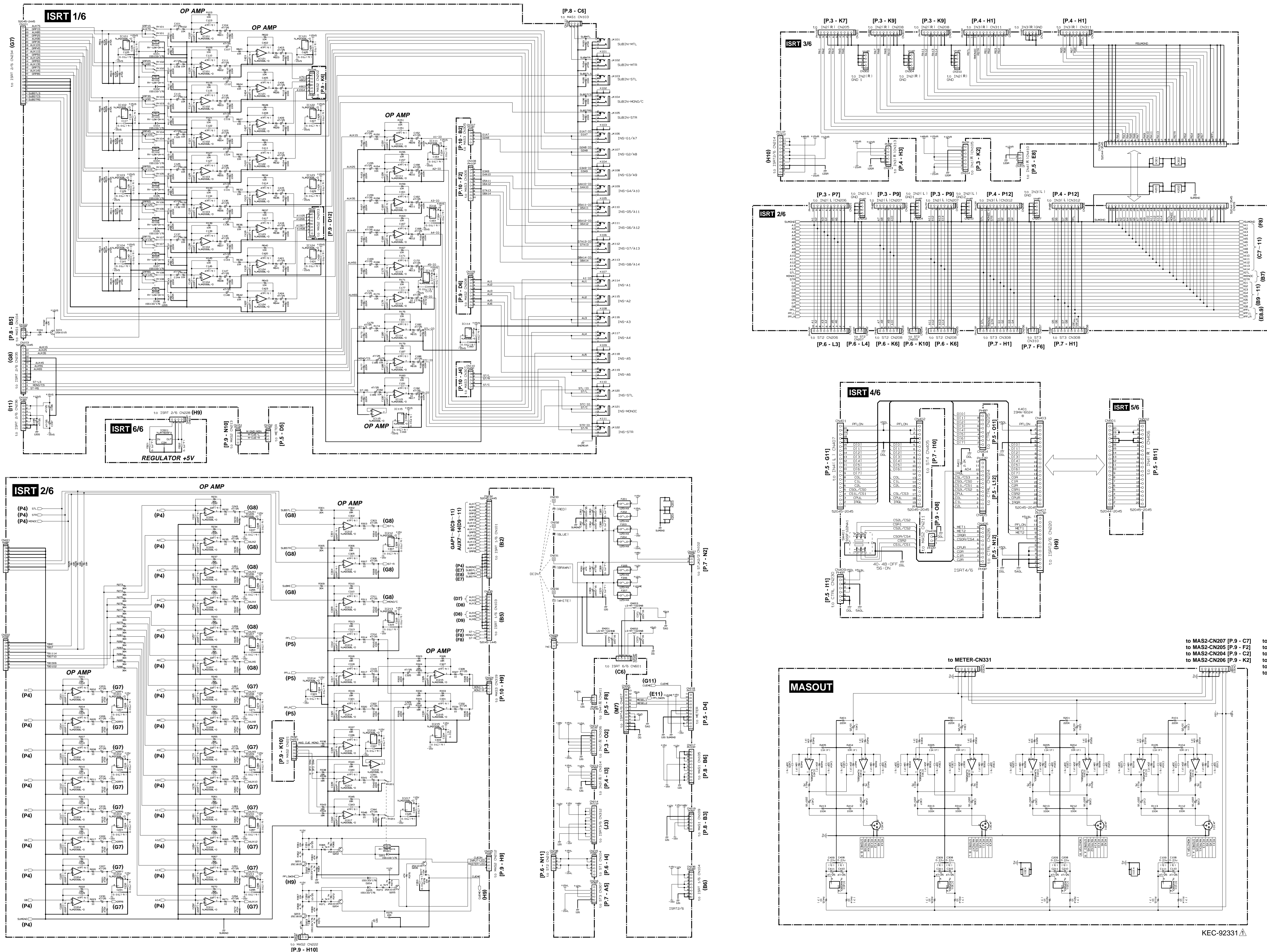

KEC-92331

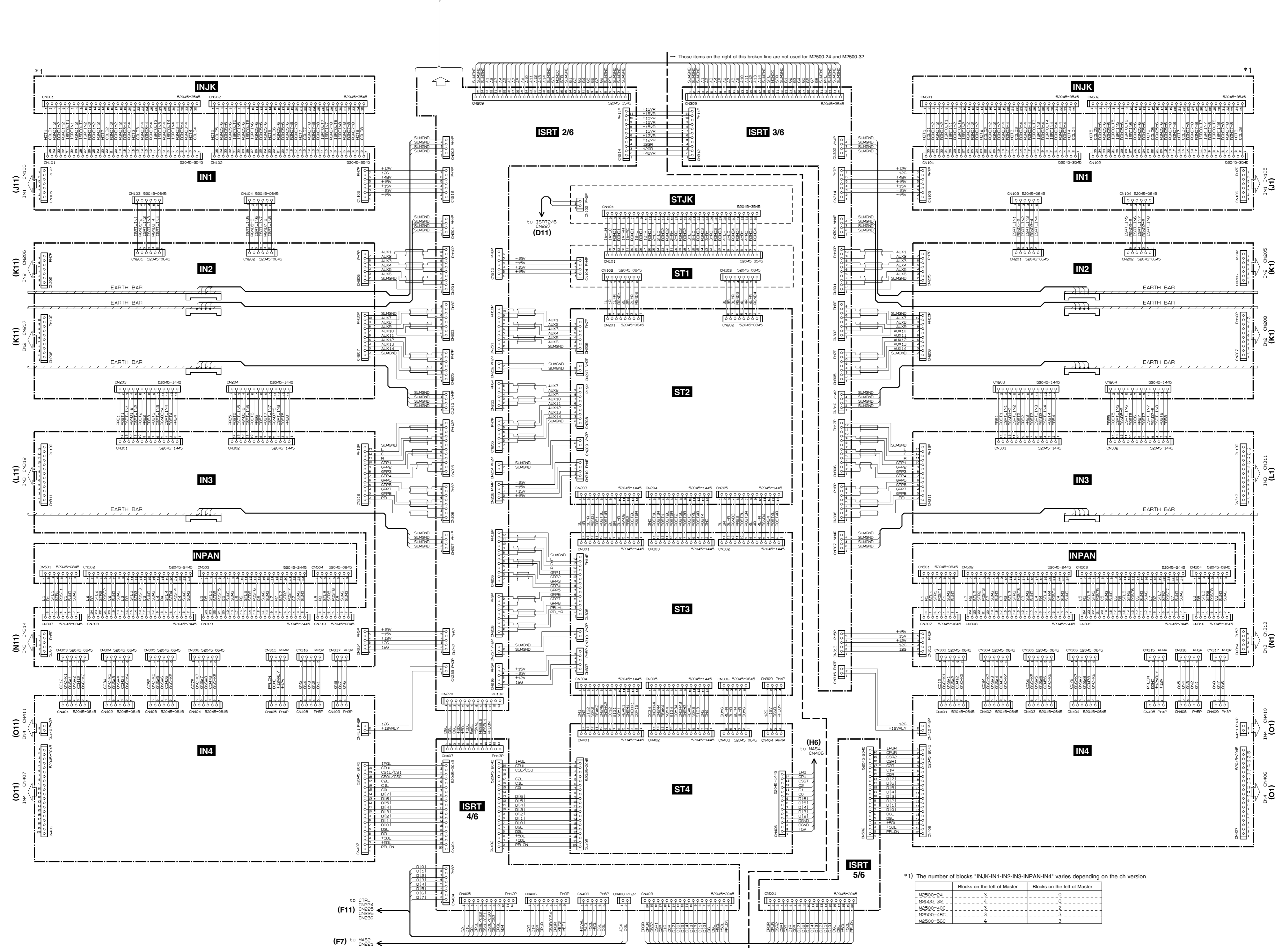
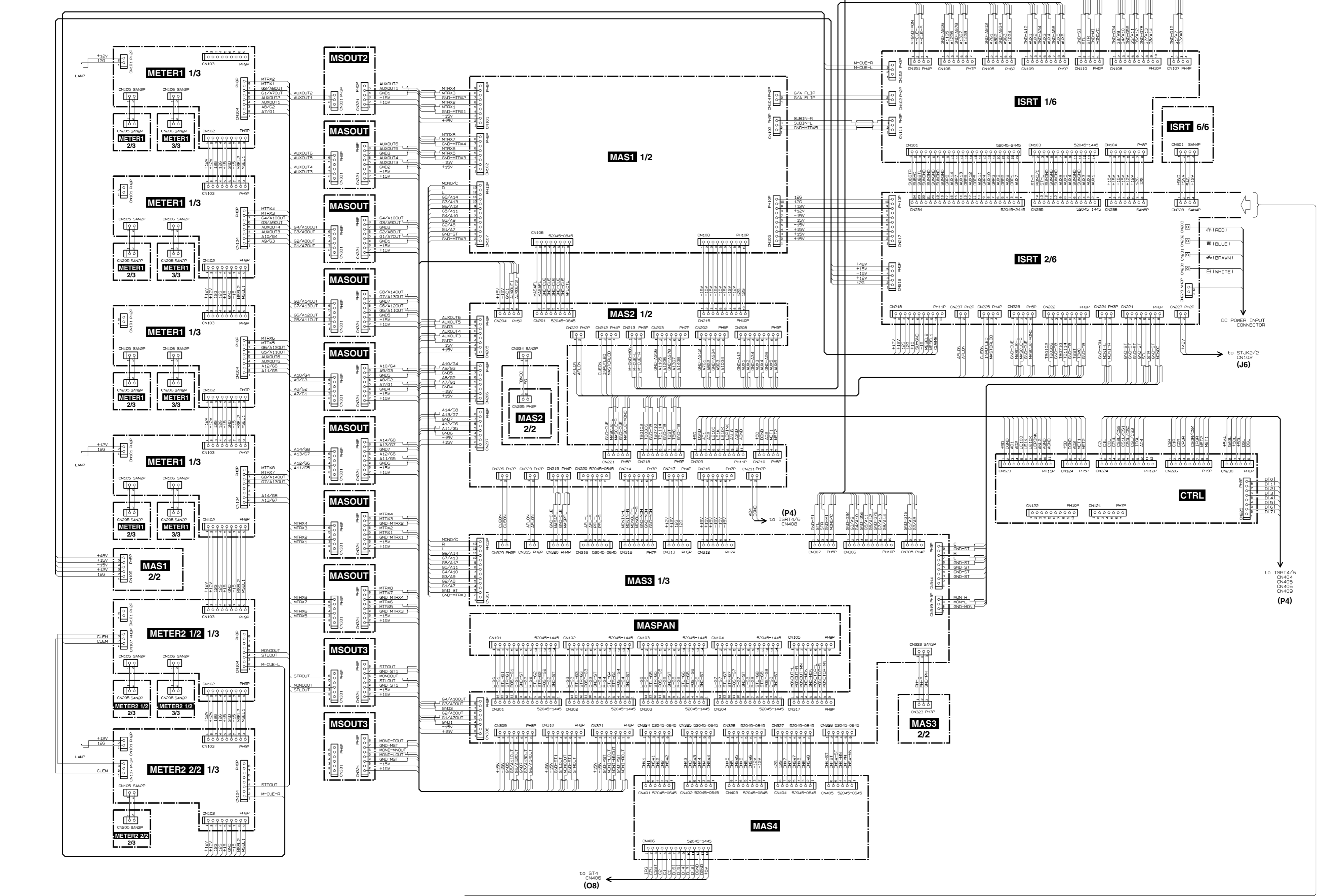

*1) The number of blocks 'INK-IN1-IN2-IN3-INPAN-IN4' varies depending on the ch version.

Blocks on the left of Master	Blocks on the left of Master
MSP0-24	1
MSP0-26	2
MSP0-28	3
MSP0-30	4
MSP0-32	5
MSP0-34	6